

4 "BIG" RADIO DEVELOPMENTS!

RADIO NEWS

AND

SHORT WAVE RADIO

SHORT
WAVE
TIME
TABLE

OCTOBER

POCKET
"SPORTSET"
FOR THE
WORLD SERIES



25¢

U. S. AND
CANADA

HENRY
MOORE
PICKEN

**WESTON
MODEL 775 SERVICE**
A complete tester . . .
really portable! Con-
tains all the features
of Models 772 Ana-
lyzer and 773 Tube-
checker.

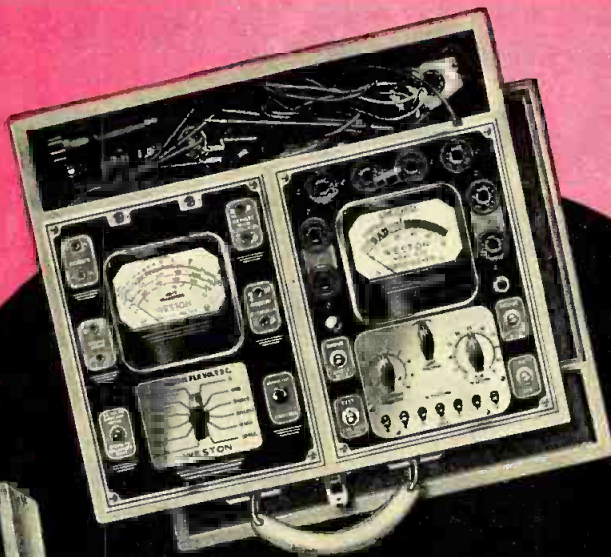

**WESTON
MODEL 772 ANALYZER**
20,000 ohms per volt . . .
actually measures 50
microamperes full scale
. . . proper condenser
leakage test on 30 meg-
ohm scale.

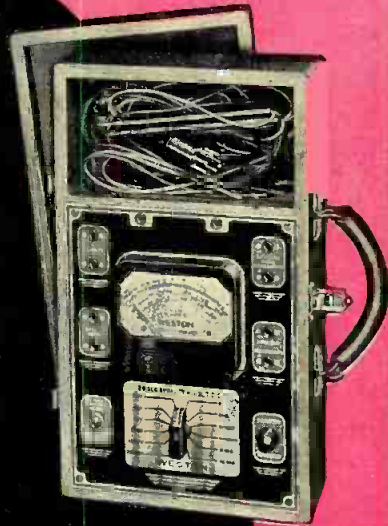

**FIRST
IN THE FIELD!**

**WESTON
MODEL 773 TUBE-CHECKER**
Special, approved Mas-
ter circuit . . . tests all
present tubes . . . spare
socket . . . noise test.



1st

**WESTON
MODEL 773 TUBE SELLER**
Contains all the fea-
tures of 773 portable,
plus built in, rapid ref-
erence rotator tube
chart. Handsome pol-
ished-wood case.



- in dependable accuracy
- in engineering and design
- in wide range of usefulness
- in operating simplicity
- in low obsolescence features
- in profit possibilities for service men

**WESTON
MODEL 771 CHECKMASTER**
Ideal field estimator
. . . tube checker, volt-
meter, ohmmeter,
continuity tester.



—and remember, all WESTON Radio Instruments can
be purchased under the convenient WESTON Invest-
ment Plan.

WESTON

GET ALL THE FACTS — RETURN COUPON TODAY

Weston Electrical Instrument Corp.,
615 Frelinghuysen Ave., Newark, N. J.
Send full data on all Radio Instruments.

Name.....

Address.....

City..... State.....



Be a Radio Expert

Many make **\$30 \$50 \$75** a week

I will train you at home for many Good Spare Time and Full Time Radio Jobs

J. E. SMITH, President, National Radio Institute
Established 1914

The man who has directed the home study training of more men for the Radio Industry than any other man in America.



Set Servicing

Spare time set servicing pays many \$5, \$10, \$15 a week extra while learning. Full time servicing pays as much as \$30, \$50, \$75 a week.

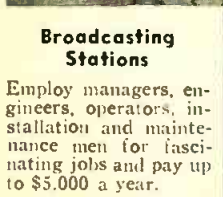

Broadcasting Stations

Employ managers, engineers, operators, installation and maintenance men for fascinating jobs and pay up to \$5,000 a year.



Loud Speaker Systems

Building, installing, servicing, operating public address systems is another growing field for men well trained in Radio.



HERE'S PROOF THAT MY TRAINING PAYS

\$80 Monthly in Spare Time

"I work on Radio part time, still holding my regular job. Since enrolling seven years ago, I have averaged around \$80 every month." JOHN B. MORISSETTE, 809 Valley St., Manchester, N. H.



Makes \$50 to \$60 a Week

"I am making between \$50 and \$60 a week after all expenses are paid, and I am getting all the Radio work I can take care of, thanks to N. R. I." H. W. SPANGLER, 126 1/2 S. Gay St., Knoxville, Tenn.



Operates Public Address System

"I have a position with the Los Angeles Civil Service, operating the Public Address System in the City Hall Council. My salary is \$170 a month." R. H. ROOD, R. 136, City Hall, Los Angeles, Calif.



Lesson on Radio Servicing Tips—FREE

I'll prove that my Training gives practical, money-making information, that it is easy to understand—that it is just what you need to master Radio. My sample lesson text, "Radio Receiver Troubles—Their Cause and Remedy" covers a long list of Radio receiver troubles in A.C., D.C., battery, universal, auto, T. R. F., superheterodyne, all-wave, and other types of sets. And a cross reference system gives you the probable cause and a quick way to locate and remedy these set troubles. A special section is devoted to receiver checkup, alignment, balancing, neutralizing and testing. Get this lesson FREE. No obligation. Just mail coupon.



Do you want to make more money? Radio offers you many opportunities for well-paying spare time and full time jobs. You don't have to give up your present job, leave home or spend a lot of money to become a Radio Expert.

Many Radio Experts Make \$30, \$50, \$75 a Week

Radio broadcasting stations employ engineers, operators, station managers and pay up to \$5,000 a year. Spare time Radio set servicing pays many \$200 to \$500 a year—full time jobs with Radio jobbers, manufacturers, dealers, as much as \$30, \$50, \$75 a week. Many Radio Experts operate their own full time or part time Radio sales and service businesses. Radio manufacturers and jobbers employ testers, inspectors, foremen, engineers, servicemen, paying up to \$6,000 a year. Radio operators on ships get good pay, see the world besides. Automobile, police, aviation, commercial Radio and loud speaker systems are newer fields offering good opportunities now and for the future. Television promises to open many good jobs soon. Men I trained have good jobs in these branches of Radio. Read their letters in "Rich Rewards in Radio." Mail the coupon.

There's a Real Future in Radio for Well-Trained Men

Radio already gives good jobs to more than 300,000 people. In 1936 Radio enjoyed one of its most prosperous years. More than \$500,000,000 worth of sets, tubes and parts were sold—an increase of more than 60% over 1935. Over a million Auto Radios were sold, a big increase over 1935. 24,000,000 homes now have one or more Radio sets. More than 4,000,000 autos are Radio equipped. Every year millions of these sets go out of date, are replaced with newer models. More millions need servicing, new tubes, repairs, etc. A few hundred \$30, \$50, \$75 a week jobs have grown to thousands in 20 years. And Radio is still a new industry—growing fast!

Many Make \$5, \$10, \$15 a Week Extra in Spare Time While Learning

Almost every neighborhood needs a good spare time serviceman. The day you enroll I start sending you Extra Money Job Sheets. They show you how to do Radio repair jobs; how to cash in quickly! Throughout your training I send you plans that made good spare time money—\$200 to \$500 a year—for hundreds of fellows. My training is famous as "the Course that pays for itself."

I Give You Practical Experience

My Course is not all book training. I send you special Radio equipment, show you how to conduct experiments, build circuits illustrating important principles used in modern Radio receivers, broadcast stations and loud speaker installations. I show you how to build testing apparatus for doing spare time servicing from this equipment. This 50-50 method of training makes learning at home interesting, fascinating, practical.

You Get a Money-Back Agreement

I am sure I can train you successfully. I will agree in writing to refund every penny you pay me if you are not satisfied with my Lessons and Instruction Service when you finish. I'll send you a copy of this agreement with my Free Book.

Find Out What Radio Offers You

Act Today. Mail the coupon now for "Rich Rewards in Radio." It's free to any fellow over 16 years old. It points out Radio's spare time and full time opportunities and those coming in Television; tells about my training in Radio and Television; shows you letters from men I trained, telling what they are doing and earning. Find out what Radio offers YOU! MAIL THE COUPON in an envelope, or paste on a postcard—NOW!

J. E. SMITH, Pres., National Radio Institute
Dept. 7KR
Washington,
D. C.

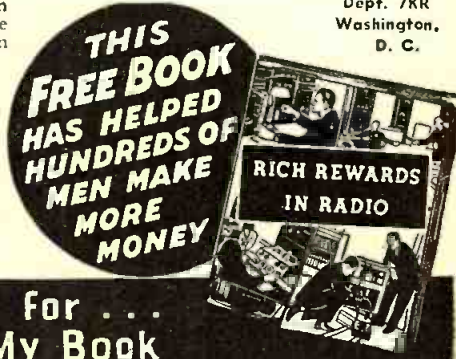

This Coupon is Good for One FREE Copy of My Book

J. E. SMITH, President, Dept. 7KR
National Radio Institute, Washington, D. C.

Dear Mr. Smith: Without obligation, send me free the Sample Lesson and your 64-page Book "Rich Rewards in Radio", telling about spare time and full time Radio opportunities, and how I can train for them at home in spare time. (Please write plainly.)

NAME..... AGE.....
ADDRESS.....
CITY..... STATE.....

14-N1



Edited by LAURENCE MARSHAM COCKADAY

S. GORDON TAYLOR WILLIAM C. DORF
Managing Editor *Associate Editor*

JOHN M. BORST JOHN H. POTTS
Technical Editor *Assoc. Tech. Editor*

"BILL" EVERETT
Art Editor

Vol. XIX, October, 1937

No. 4

Reading Guide to this Issue—

AMATEURS—3, 6, 7, 8, 9, 10, 11, 12, 13, 15, 18, 26, 27
 BROADCAST FANS—2, 3, 4, 6, 14, 20, 27
 DEALERS—1, 3, 7, 17, 19, 23, 26, 27
 DESIGNERS—3, 7, 9, 10, 14, 26, 27
 DX FANS—3, 6, 14, 20, 21, 27
 ENGINEERS—3, 5, 9, 10, 14, 18, 26, 27
 EXPERIMENTERS—3, 4, 5, 6, 7, 9, 13, 15, 18, 26, 27
 MANUFACTURERS—3, 5, 26
 OPERATORS—2, 3, 25, 26, 27
 SERVICEMEN—1, 3, 7, 13, 14, 16, 17, 19, 26, 27
 SET BUILDERS—3, 4, 6, 7, 13, 14, 15, 26, 27
 SHORT-WAVE FANS—3, 5, 11, 14, 20, 22, 27
 STUDENTS—1, 3, 4, 5, 6, 7, 9, 13, 14, 15, 16, 17, 18, 19, 20, 24, 26, 27
 TECHNICIANS—3, 7, 10, 13, 16, 18, 19, 26, 27

Next Month—

THE first of a series of articles on antennas will be presented in the November issue. It will deal with fundamental theory, in terms which the non-technical reader can understand. This is something for which there has been a real need and it is felt that this series will provide one of the outstanding features of modern radio literature.

1	Serviceman's Diary	<i>Anonymous</i>	196
2	American Broadcasting Dresses Up	<i>Samuel Kaufman</i>	199
3	What's New In Radio	<i>The Associate Editor</i>	201
4	Build a Pocket Sportset	<i>A. J. Haynes</i>	202
5	Television Range Extended	<i>John Strong</i>	203
6	The Radio Beginner (Part 14)	<i>John M. Borst</i>	204
7	Electronic Signal Mixer	<i>Gerard J. Kelley</i>	205
8	The "Ham" Shack	<i>Everett M. Walker</i>	206
9	5-Meter U-Beam Antenna	<i>Robert Ames</i>	207
10	1-Kw. Transmitter for 10 to 20 Meters (Part 3)		208
11	The Amateur Observer	<i>W2JCR</i>	210
12	10 to 160-Meter Transmitter	<i>Everett M. Walker</i>	211
13	The Radio Workshop	<i>William C. Dorf</i>	212
14	New "Masterpiece" 21-Tube Receiver	<i>McMurdo Silver</i>	213
15	The "Tiny Tot" Mobile Transmitter	<i>A. J. Haynes</i>	214
16	Inter-Office System Layouts	<i>J. Erwood</i>	215
17	The Service Bench	<i>Zeh Bouck</i>	216
18	Wien Bridge Frequency Meter	<i>W. J. Creamer</i>	218
19	Servicing Movie Sound (Part 3)	<i>W. W. Waltz</i>	219
20	Air-Testing the "Philharmonic"	<i>Cockaday and Taylor</i>	220
21	Station List (Asia, Africa, Australia—Broadcast)		221
22	The DX Corner for Short Waves	<i>Laurence M. Cockaday</i>	222
23	World Short-Wave Time-Table	<i>S. W. DX Editor</i>	224
24	Students' Radio Physics Course	<i>Alfred A. Ghirardi</i>	230
25	Q R D?	<i>By G Y</i>	232
26	The Technical Review	<i>The Technical Editor</i>	240
27	Free Booklet Service		241

Published Monthly by Teck Publications, Inc., Washington and South Avenues, Dunellen, N. J.

Lee Ellmaker
President and Treas.
 B. Holcepl
Secretary
 Walter C. Freeman
Eastern Advertising Manager
 Virgil Malcher
 605 N. Michigan Ave., Chicago
Western Advertising Manager

EDITORIAL AND EXECUTIVE OFFICES
 461 EIGHTH AVENUE, NEW YORK CITY, N. Y.

Entered as second class matter at the Post Office at Dunellen, N. J., under the act of March 3, 1879. Copyright, 1937, by Teck Publications, Inc., in U. S. and Canada. All rights reserved. Registration of title of this publication as a trade mark applied for in United States Patent Office. Printed in the United States of America. The contents of this magazine must not be reproduced without permission. We cannot be responsible for lost manuscripts, although every care is taken for their safety.

25c a copy. Subscriptions, \$2.50 a year, \$4.00 for two years; in Canada and Foreign Countries \$3.00 a year, \$5.00 for two years. Subscribers are notified that change of address must reach us five weeks in advance of the next date of issue.

THE Amazing NEW SCOTT Philharmonic

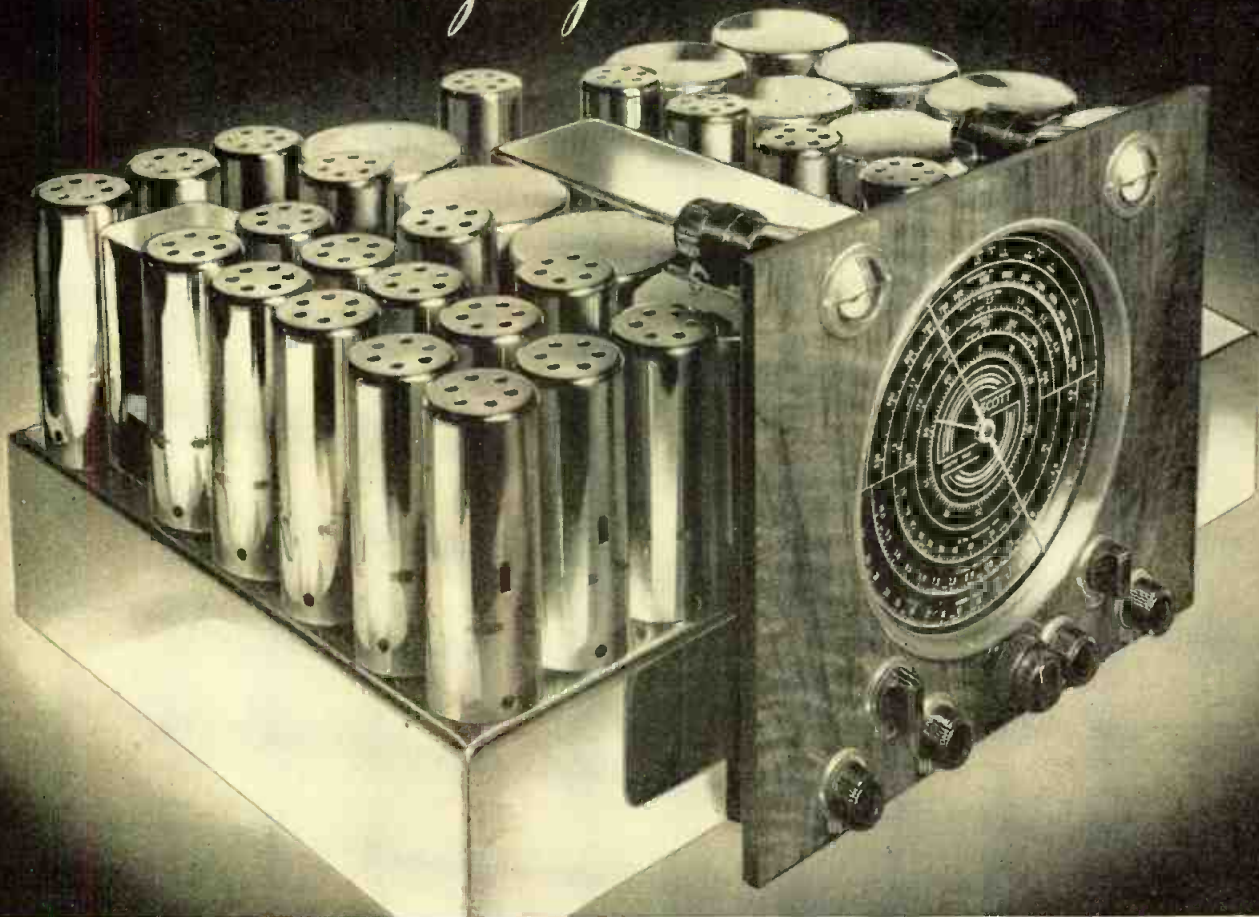

WORLD'S MOST POWERFUL RADIO.

The sensationally quiet long-distance performance and perfection of tone achieved by the New Custom-Built Scott "Philharmonic" is due to a large number of exclusive developments perfected in the Scott Research Laboratory. Following are a few highlights.

Increased Wave Length Range 3.75 to 2000 Meters . . . Tunes Every Broadcast on the Air

The Scott "Philharmonic" has a tuning range from 3.75 to 2000 meters, making possible the reception of special Experimental and Television sound broadcasts on the Ultra-Short Waves—Foreign stations in all parts of the world—All of the stations on the standard Broadcast Band—Aviation and Weather reports on the Long Wave Band—covering efficiently a greater wave length range, we believe, than any other radio receiver in the world today.

Super-Powered for QUIETER Foreign Reception from All Parts of the World

When you hear Foreign stations coming in on the New Super-powered 30 Tube "Philharmonic", you find it impossible to believe you are listening to stations thousands of miles away—The extremely high degree of usable sensitivity on all wave bands is largely due to the efficiency of the highly developed Two Stage R.F. Amplifier—The Four Stage I. F. Amplifier—and the 40 Watt Class A Audio Amplifier.

New Variable Band-Pass Selectivity

On the New "Philharmonic" an exclusive method developed in our Research Laboratory continuously varies the Selectivity from 2 to 16 Kc., enabling you to reach out and bring in weak distant stations which ordinarily would be completely blanketed by interference from powerful local stations on adjacent channels.

Four New Developments Revolutionize Tone—Amazes the Music World

Unquestionably, one of the most outstanding features of the Scott "Philharmonic" is the almost unbelievable realism of its tone. This is due largely to a number of recently perfected developments, among them: (1) New Scott R. F. Amplifier development (Scott Patents Applied For) which automatically band-passes the R.F. stages to 18 Kc. (on broadcast band) and variable I.F. Selectivity, enables all frequencies up to 16,000 cycles to be reproduced, securing true high fidelity reception. (2) NEW Scott Bass Bi-Resonator System (Scott Patents Applied For) which provides perfect reproduction of bass or lower tones without muffling reproduction of speaking or singing voice on higher frequencies. (3) Special Tone Balanced Volume Control scientifically designed to follow response of ear to all frequencies at varying degrees of volume. (4) New Inverse Feed-back System which automatically cuts down "peaks" and brings up "dips" of speaker, giving finer, truer tone.

Perfect Push-Pull Volume Range Expansion

A special Push-Pull Program Volume Range Expansion circuit developed in the Scott Research Laboratory provides a range of 15db enabling the dynamic variations of all programs to be restored to their original volume range. Until you have heard this new development, it is impossible to realize how fine both radio reception and phono reproduction can really be.

Newly Developed Circuit Suppresses Scratch On Phonograph Records

A development of the Scott Research Laboratory (Scott Patents Applied For) automatically suppresses the scratch on the record, but does not affect the full reproduction of the higher frequencies at normal volume. This amazing development for phonograph record reproduction cannot be realized until one has actually listened to a phonograph record played in the ordinary way, then with the record scratch eliminated. This is undoubtedly one of the most outstanding developments in phono reproduction.

Guaranteed for 5 Years Against Defects

The "Philharmonic" is custom-built in limited numbers, with such extreme precision and with such high quality parts, by highly skilled laboratory technicians, that it is guaranteed against defects (except tubes) for FIVE YEARS—20 times longer than the usual 90-day guarantee of production type receivers.

Prices No Higher Than Many Ordinary Radios

Contrary to general opinion, Scott Receivers are priced no higher than many ordinary radios. They are sold only direct from the Scott Laboratories—there are no dealers—thus saving you the distributor and regular radio dealer's profit.

30 Day FREE Trial . . . Liberal Terms

Try the Scott "Philharmonic" in your home for 30 days! If it is not finer and better in every way, you can return it at any time during this period and your money will be promptly refunded. Liberal Budget Plan terms, if desired.

Scott Demonstration Salons

New York City 630 Fifth Ave.
Los Angeles 115 No. Robertson Blvd.
Chicago 4440 Ravenswood Avenue

FREE! SEND COUPON FOR INTERESTING FREE DETAILS ON THIS SENSATIONAL NEW 1938 RECEIVER AND SPECIAL MONEY SAVING OFFER DURING THE NEXT 30 DAYS!



E. H. SCOTT RADIO LABORATORIES, INC.

4440 N. Ravenswood Ave., Dept. 5R7, Chicago, U. S. A.

Please send full description, prices and FREE details on the special offer you are making during the next 30 days on the New Scott Philharmonic. No obligation. (Not sold thru dealers—sold only direct from Scott Laboratories).

Name
Street State

Pages From A
Serviceman's
DIARY

WEDNESDAY: Off to church. No, not to get soothing syrup for an aching soul; only to fix an ailing radio. It was quite a long trip out to the rectory, and I wondered what type of clergyman I was going to run into. Most of those I have run into are fine, human fellows who feel no divine dispensation sets them apart from the rest of us. I like them.

The rectory was a small cottage with a wooden fence surrounding it. The gate was hospitably open and the flowers and shrubbery made the place very attractive. I was sure I'd like this minister. He was in his shirt sleeves when he came to the door, his collar off. Rather young, with a clear ruddy complexion instead of the usual ministerial pallor. You could see he was new to the church. He didn't offer to shake hands the moment he saw me, but got right down to business.

"There's the radio." He pointed to a big Radiola RAE-79 in the corner of the room. "In a weak moment I went down to your store and selected it. I had no right to spend so much money for a radio. I don't like it, yet I haven't the moral courage to ask them to take it back. The record player doesn't work right. Do you think you can fix it?"

I hoped so. Started to work on it, trying out a few records, meanwhile wondering how the poor fellow got along if he were short of moral courage. I thought that should be his main stock in trade but if he had to deplete his resources it was just as well that our concern should be the beneficiary.

It changed the first two records okay but on the third one the needle didn't fall in the starting groove. I went behind the set and took up on the wire cable. Tried it again.

"Now okay," I told our clergyman. He seemed pleased as I pushed the set back in place and told him that it appeared to be all right now.

"Sweet and Lovely"

"Here is my favorite record," he said. "Try this." I looked at the title, "Sweet and Lovely!" (Phoocy! And I thought he was a regular guy!)

"Sit down and enjoy it with me," he invited. (What else could I do?) I set the mechanism to repeat the record and then took a chair near him. He leaned back and closed his eyes. When the song finally ended I anxiously watched the pick-up arm rise and move back to the starting position. Would it come down in the right groove? It would not. It was worse than ever.

He didn't say anything. Neither did I. I moved the set out and took up some more on the cable. Then once more "Sweet and Lovely." This time I started near the end of the record. He looked a little hurt, but I told him it would save time. Again the mechanism operated okay and again I shoved the set back in the corner. This time, I hoped, the job was finished. Sat down and resolved to suffer through "Sweet and Lovely" once more. But again the blankety-blank arm didn't come down in the right spot.

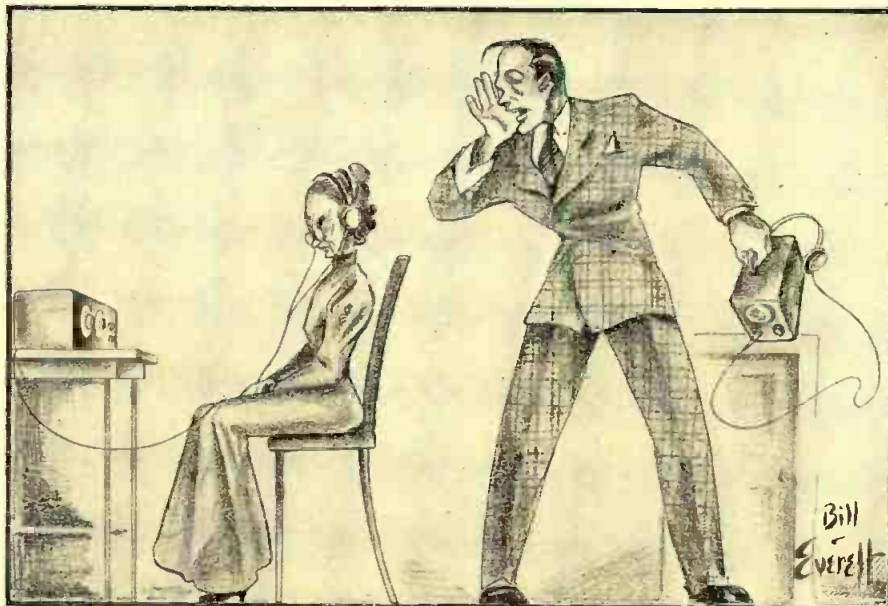

THE SERVICEMAN FINDS A GOOD BUSINESS IN HEARING AIDS

Where there is a person who is hard-of-hearing in a family, the radio serviceman is one of the first to hear about it and he is often called upon to furnish a unit for attachment to the radio receiver. If he is wide-awake, the serviceman will provide a hearing aid which will accomplish this and at the same time be useful to the user in ordinary conversation.

He looked at me sympathetically. "Cuss if you want to. I know you will feel better. Don't mind me."

What a relief! I felt better right away, without cussing. I thought over the situation. It worked all right with the set out of the corner and no good when back in the corner. Therefore the position of the set must have something to do with the operation. I got down and sighted along the floor. There was a slight slope toward the side and rear. Went down to the cellar and got a small block of thin wood and leveled the set off. Then tried it again without any more adjustments. (How did it work? Sweet and lovely!)

A Good Side Line

Dropped in at the second call, where a deaf old lady was in difficulties because the earphones connected to her radio had ceased to function. A simple trouble, the tinsel cord having broken at one pin terminal. The Radiola 17 to which she had the phones connected has pin-jack receptacles in the back so she couldn't see where the break occurred without moving the set, which, like most people, she dreaded to do. Soldering tinsel cords is difficult if a soldering iron is employed, so I moved out to the kitchen and appropriated the gas range for the purpose. Holding the tip with a pair of pliers over the open flame, the job was quickly and satisfactorily completed.

The set was pretty bad. Volume control

noisy and a weak sputtering sound indicated a defective audio transformer. The tubes were weak and, with prolonged use at high volume, the phones had developed rattles and poor sensitivity. It would scarcely be fair to the customer to run up a big repair bill on a set so old, though the old lady liked it. She had become used to the type of reception which it gave, bad as it was.

Her son asked me if there was any way whereby the phones might be connected to their other radio, a large all-wave receiver, so his mother might listen to a greater variety of programs without changing the loudspeaker volume for the rest of the family. (This I could of course arrange by putting a volume control on the phones and connecting across the output transformer primary, but it occurred to me, why not do a real job and supply the old lady with a hearing aid so she could not only listen to the programs but also join in the conversation? After all, why should she be handicapped when a simple microphone and two-stage amplifier might practically bring her hearing up to normal?)

I rushed back to the shop and picked up a hearing aid which we had been experimenting with at various times. It consisted only of a carbon mike, a 2-stage amplifier using two type 30 tubes with the filaments in series, 45-volt B and 4½-volt A batteries. Returned, finding the customer seated at the radio with the phones clamped over her ears. It was quite a job to get her away from the set, but eventually she did consent to try the hearing aid. Never before had I seen a customer so delighted! And also the family, who no longer had to yell to make themselves heard. Selling becomes service when you supply a customer with something which needs no sales talk to demonstrate its worth. We are going to get in some more of these hearing aids so other customers can try them out.

THESSE records from an anonymous serviceman's diary should be of decided interest to veteran servicemen, as well as to those whose experience in the service field is more limited. Written by a man who "knows his stuff," and shot with an occasional outcropping of humor, these items provide many hints not found in text books. More of these pages will appear from time to time.

NEXT MONTH
 an article will tell of
 Mobile P.A. requirements

New LABORATORY Test Bench Panels

BY



Model 1404
with

- 1210-A Tube Tester
- 1232 Signal Generator
- 1209-A A.C. Voltmeter
- 1209-D D.C. Volt-Ohm-Milliammeter

Radio servicing engineers will welcome these new Laboratory Test Bench Panels by Triplet. They offer an easy, convenient way of permanently installing and using those instruments which are intended for use at the bench.

Furthermore, Triplet standardization in size makes it thoroughly practical to start with one or more instruments.

Model 1404 has four compartments for Triplet Master Units only. It is compact, convenient and practical. Every dial and control is in full view and easily accessible. The cabinet may be purchased alone or with one or more instruments and lamp. Additional testers may be added to the panel as needed.

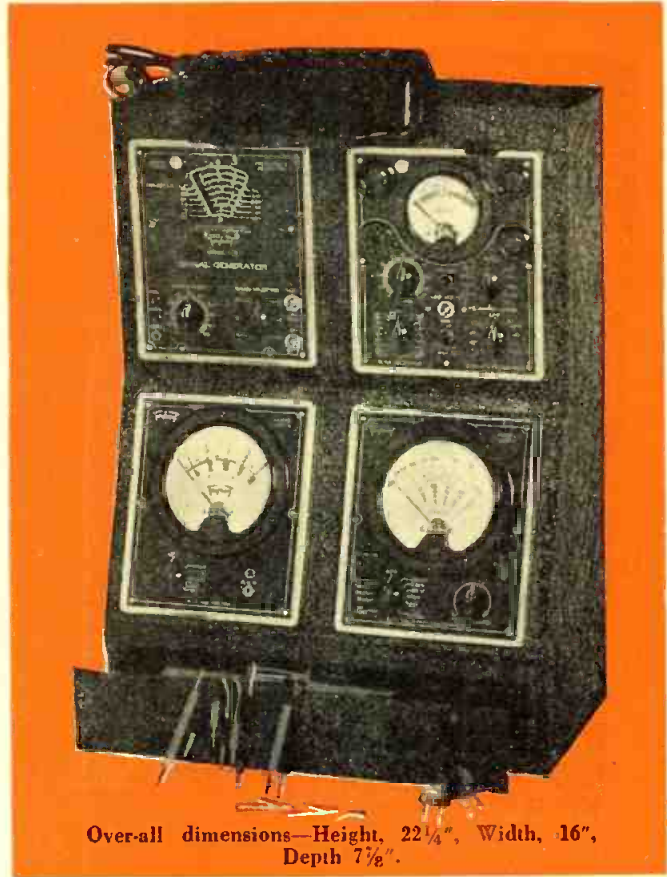

Over-all dimensions—Height, 22 1/4", Width, 16",
Depth 7 1/8".

Model 1404
Complete (less lamp)..... **\$92¹⁸**

Other Models Available:

Model 1402 with compartments for any two DeLuxe Testers; Model 1403 with accommodations for any two Master Units and one DeLuxe Tester.

Models 1402, 1403, 1404—Cabinets Only—
DEALER NET PRICE—\$10.00 each

Model 1499—Lamp Only—
DEALER NET PRICE—\$6.67

Two or more cabinets may be bolted together as a continuous panel for bench use. In this way complete instrumentation can be attained for the service bench in compact convenient form.

**FOR MORE INFORMATION SEE YOUR JOBBER OR
WRITE FOR CATALOG**

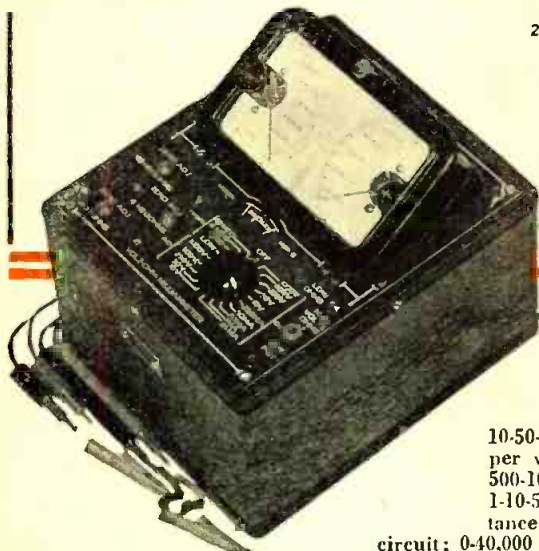

25,000 Ohms Per Volt in
Model 1200-E
Volt-Ohm-Milliammeter
\$31¹⁷

For All Radio Measurements Not Requiring a No Current Draw Vacuum Tube Voltmeter.

Readings: D.C. Volts 10-50-250-500-1000 at 25,000 ohms per volt. A.C. Volts 10-50-250-500-1000. 50 D.C. Microamperes, 1-10-50-250 Milliamperes; Resistance 0-1000 Low Ohms; Backup circuit; 0-40,000 Ohms; 4 and 40 Megohms.

The Triplet Electrical Instrument Co.
1510 Harmon Ave., Bluffton, Ohio.

Without obligation please send me more information on: Triplet Model 1404. Model 1200-E
I am also interested in.....

Name.....
Address.....
City..... State.....

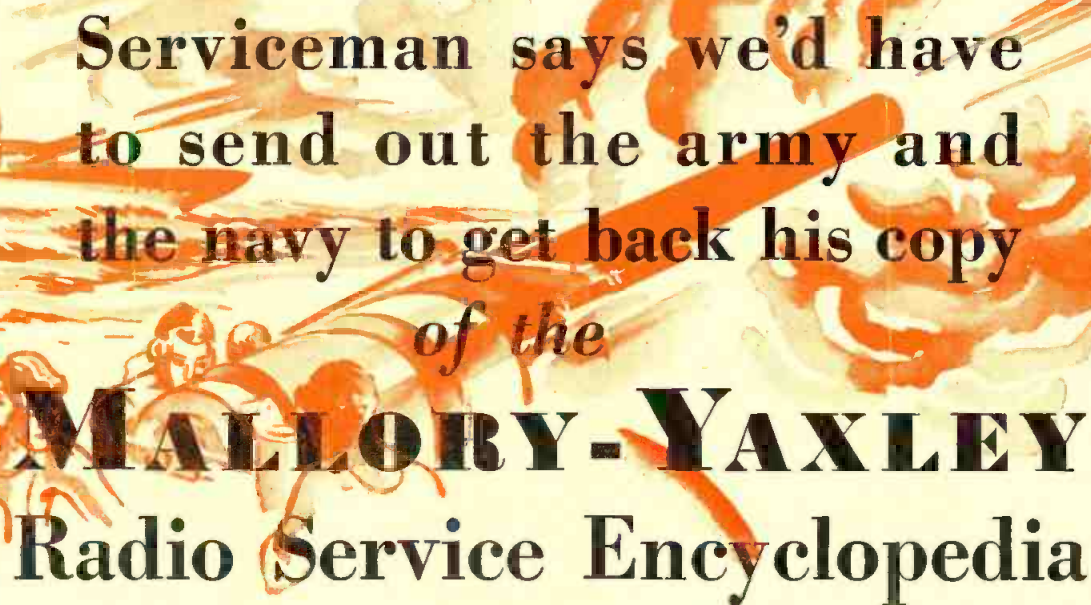

Serviceman says we'd have
to send out the army and
the navy to get back his copy
of the
MALLORY-YAXLEY
Radio Service Encyclopedia

WHEN Byford Dunn—proprietor of Dunn's Radio Shop at Carrier Mills, Ill.—likes something he doesn't mind saying so.

"A word about your Mallory-Yaxley Radio Service Encyclopedia," writes Mr. Dunn. "It is the last word in 'Labor Saving Machines'. The only way to get mine back would be to trade me a better one—or send out the army and navy! If I had not had that book I would have been up in the air a few days ago. A boy brought in a radio he had taken the old volume control out of and with the wires cut where they fastened in the radio and not on the control. With my Mallory-Yaxley Radio Service Encyclopedia I had it going in a few minutes—and there was the price of my manual!"

F. C. Robinson, of Livingston, Montana, is equally enthusiastic. He writes: "The Mallory-Yaxley Radio Service Encyclopedia is a fine book and well worth much more than was charged for it. It will

help many a serviceman out of a tight place!"

Read this . . . from Sanford Helt, Chief Engineer of the American Broadcasting Corp., at Lexington, Kentucky . . . "In my fourteen years of radio, I've never seen anything to equal your Mallory-Yaxley Radio Service Encyclopedia. I bought the volume as soon as it came out as I wanted it in my technical library."

Interesting reading, these comments from other men in the field! But—how about you? When are you going to save those extra hours and make those extra dollars that other men are saving and making with this great book that completely covers Schematics-Circuits, Volume Controls, I. F. Peak Frequencies, Transformer Circuits, Condensers, Tubes and Vibrators?

You'll have to act promptly, for there are only a few copies left. See your Mallory-Yaxley distributor right away about this greatest help a serviceman ever had!

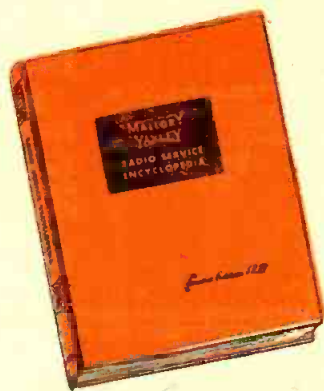

Use

P. R. MALLORY & CO. Inc.
MALLORY
REPLACEMENT
CONDENSERS... VIBRATORS

P. R. MALLORY & CO., Inc.
INDIANAPOLIS INDIANA
Cable Address—PELMALLO

Use

YAXLEY
REPLACEMENT
VOLUME CONTROLS

Radio News

October, 1937

American BROADCASTING

Starts Dressing Up

By Samuel Kaufman

DOWN with the old and dingy! Up with the new and beautiful! There, in a few words, is the slogan radio stations from coast to coast are following these days. Studio reconstruction and modernization, a sort of large-scale "dressing up" program, is under way in all parts of the U. S. A., indicates that all stations—big and small—are realizing scientifically advanced and beautified program suites mean better transmission and reception. At one time, the studio was the last consideration in a station's modernization campaign; today, it's virtually the first.

In the April, 1937, issue, RADIO NEWS set forth details on new studios in several American cities. Since the date of that writing, there has been a deluge of new announcements of studio rebuilding. The makers of studio materials are experiencing an unprecedented spurt in orders. The broadcasting industry, unlike many others, believes in investing a large share of its profits in modernization, and the current epidemic of new studios reveals that broadcasters are making practical applications of new studio devices and techniques as soon as they are made available by engineers and scientists.

Chains Active

Network stations, particularly, are endeavoring to emulate their key units in respect to design, if not in size. As a result, many NBC and CBS affiliated stations are prominent in the roster of new studio builders. Many of the new studios are providing for the future development of television activities, this move indicating that the new art is closer than many radio executives care to admit.

In addition to a main studio building and three

theatres in New York, the Columbia Broadcasting System has seen fit to add four modern, beautifully equipped studios in a Times Square building. These are defined as "permanent" studios and will probably be retained even after the completion of the new CBS headquarters now being designed by architects, the site previously chosen.

The Times Square studios, at 799 Seventh Avenue, contain such essential supplementary space as a large foyer, offices and special rooms for engineers, musicians, sound effects and storage. Each studio has its own control room and the two largest chambers have clients' audition rooms as well. The largest studio utilizes the advanced semi-live end, dead end acoustic principle. A large Kimball organ was erected in one of the new broadcasting rooms. Separate corridors have been provided for personnel and visitors.

WBBM's new studios, which are the Chicago headquarters of CBS, occupy part of the main floor and the entire second floor of the North Wrigley Building. This entire broadcasting layout was designed by William Lescaze, who also served as architect for the chain's elaborate New York and Hollywood broadcasting centers.

New Effects

A feature of the Chicago unit is a radio theatre that boasts a new modernistic motif. Built with no two walls parallel—claimed to be the latest acoustical "advance"—the auditorium and stage offer a novel effect to eye and ear. The control booth and client boxes are suspended from the ceiling, curved windows permitting full-range views of performers and guests. Even the desks and speaker cabinets were built to order to assure

BROADCASTING FROM A ZEPPELIN?

Although at first glance this looks like the control room of an airship it is really the new control room of Studio 10 WBBM, Chicago. Just one idea of how American stations are using the "modern" motif in buildings built especially for broadcast use.

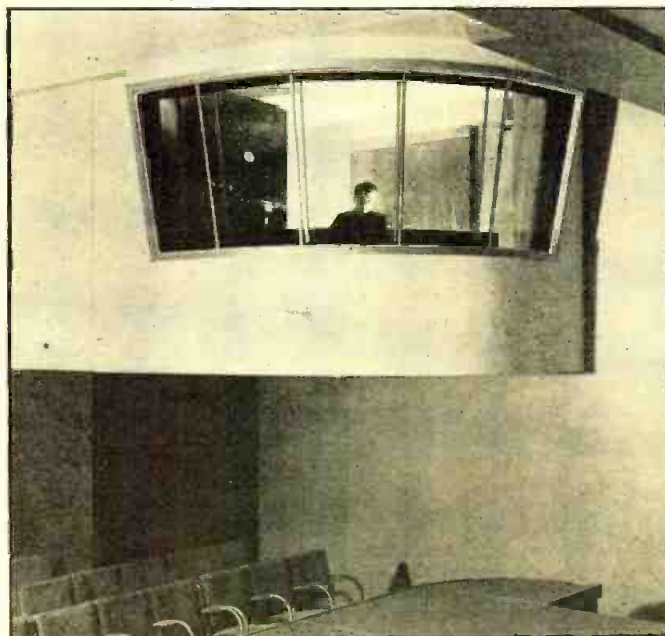



THE CLIENT'S ROOM AT WKRC
Here is where the sponsor may sit, hear and view his broadcast as it is being broadcast. Note the simplicity of line and the acoustically treated walls.

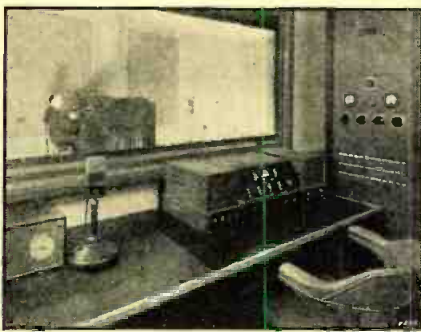

WABC'S ORGAN STUDIO

Mighty organ tones are now truthfully reproduced from this studio designed especially for the purpose. Note the control man's complicated monitoring unit.

along with "floating" sound insulation. The modernistic motif is followed throughout.

WKRC also boasts a complete new transmitter with day power increased to 5,000 watts, night power remaining at 1,000 watts. The only things not new at WKRC are the two antenna towers atop the Hotel Alms.

Ground was recently broken in Philadelphia for the construction of a six-story building at 1619 Walnut Street to house the Quaker City studios and offices of KYW, the Westinghouse transmitter managed by NBC. The studio cost is estimated at \$600,000 and occupancy is set for November 1 of this year.

Excepting the first floor, the entire structure will be used for studios and offices. One innovation, here, is the location of the auditorium studio in the basement. This studio, seating over 200, will contain a stage and a demonstration kitchen for domestic science broadcasts. The second floor will house the main operations suite. Three principal studios will be on this level with observation galleries in the mezzanine. A smaller (Turn to page 250)

SUSPENDED WALLS AND CEILING

This cut-away view of modern studio construction reveals a maze of concealed ducts.

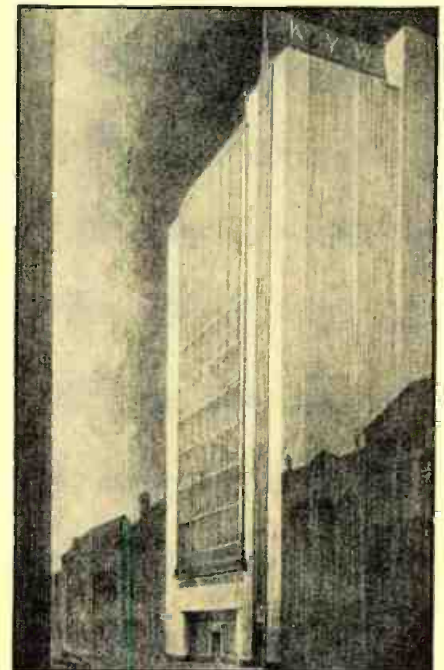

harmonizing with the decorator's theme. One of the latest principles of scientific lighting is applied here with two white and two gray walls reflecting the indirect lighting to best advantage. This unique broadcasting chamber will be supplemented by two additional units at a date subsequent to this writing.

New studios and offices for WKRC, Cincinnati CBS outlet, were opened in the spring. They are located at the Hotel Alms and followed the design of the chain's New York headquarters. Here, the live-end, dead-end principle is also employed in the auditorium studio,

FOR CHAMBER MUSIC

WBBM's Studio 9 designed along the "one dead end" principle in acoustic architecture.



WHAT'S NEW in RADIO

By The Associate Editor

Multiple Crystal Holder

Four separate crystals can be accommodated in the new National crystal holder, any one of which may be selected by the built-in switch. One metal plate, 2 $\frac{1}{8}$ by 1 $\frac{1}{4}$ by $\frac{3}{8}$ inches thick is common to all

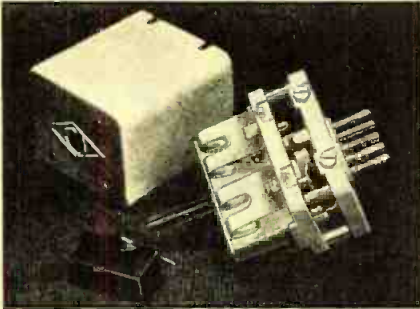

four crystals. This large mass of metal is said to retard temperature changes and provide cooling for the crystal. The switch has extremely low distributed capacity. The unit has a standard five prong plug-in base and in most cases can be substituted for existing holders without change. Provision has also been made for mounting behind the panel, with front-of-panel control.

Auto Speaker

The Wright-DeCoster Company introduces their model No. 1136 "Nokoil" automobile reproducer. This is a permanent magnet type speaker requiring no field current. The cabinet can be mounted either by a single stud or base mounting. The

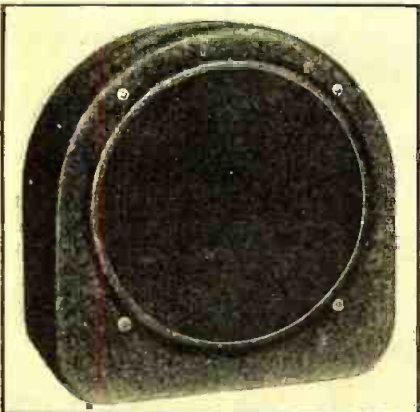

screen covering the grille opening is dusted with a velvet fibre which gives a rich velvet finished appearance. Yet, there is no grille cloth of any kind and the sound is allowed free passage.

New Cathode-Ray Tube

New York, N. Y.—National Union has announced a new 2-inch cathode-ray tube,



THAT OLD INSTITUTION, THE ARMY BUGLER, IS NOW A "ROBOT" Out at Mitchell Field, the Army Air Base, science has arranged a device that allows the bugler to stay in bed at 5 a.m. There is now in use a new Lafayette phonograph and P. A. amplifier that plays "reveille". All the operator has to do is to start the phonograph, set the pick-up on the record and the trumpet rings out loud and clear from the powerful loudspeakers atop the administration office.

type 2002. Its overall length is 6 $\frac{1}{2}$ inches and it employs an octal 8-pin base with the same scheme of connections as the 913. The maximum anode potential required is 600 volts. The sensitivity varies, according to the anode voltage from .23 to .14 mm per volt (d.c.); deflections for a.c. are 2.8 times as large.

6Y6G

New York, N. Y.—A new power pentode has been announced by Raytheon; the tube to be known as 6Y6G. It is designed to deliver a maximum of 3.6 watts power with a plate and screen potential of but 135 volts. It is considered that a considerable saving could be made if lower voltages were employed in a.c. receivers. Until now no power tube would deliver enough power with so low a plate voltage. The transconductance is 7000 micromhos, the required load-inductance 2000 ohms, plate current 60 ma, filament 6.3 volts at 1.25 amps. Distortion at 3.6 watts—2.5 percent second and 9-percent, third harmonic.

New Line of Sound Systems from 10 to 60 Watts

The Hetro Electrical Industries introduces a series of new P.A. systems, which are bound to receive special attention from servicemen and sound engineers. The 60-watt model AP600, illustrated here, is rated at 135 db. gain, adequate for direct operation of all modern microphones. The specifications show a frequency response flat within 1 db. from 40 to 10,000 cycles. It is a complete unit, with the multiple channel pre-amplifier, driver and output stages, monitor speaker and power supply all housed in one steel cabinet. The monitor speaker will be appreciated where monitoring of input and tone controls cannot be done from the speaker system.

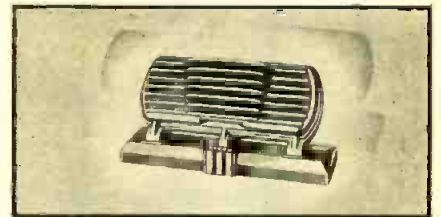

Novel Velocity Microphone

The new Bruno model OR microphone is a magnetic velocity type designed especially for pulpit or desk work.

This design does away with the conspicuous banquet stand. Freedom of movement is assured the orator through a tilting arrangement of the "mike" stand and directional "fins" which provide a wide range of pickup. Its output is rated at minus 65 db. and it can be supplied in high- and low-impedance models.

Tone Monitor Big Feature in 1938 Radios

The "Tone Monitor" is one of the outstanding features of the 1938 General Electric radio receivers. It is employed to extend the reproducing range of the set, both high and low tones in proper proportion, also to correct the effect of peaks, boom and distortion of individual notes to make possible fuller, richer tone especially in the table models and other types with limited baffle areas.

The "Louver Dial" will of course create

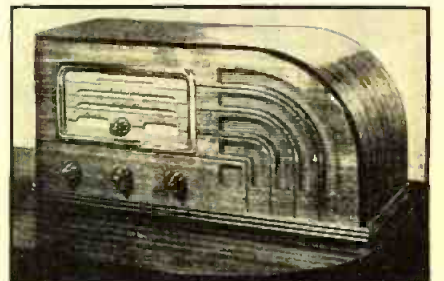

a great deal of interest, as well as the new cabinets and other developments. The attractive table model, illustrated, is a 2-band, 6-tube set with a frequency coverage of (Turn to page 244)



A POCKET FULL OF ETHER WAVES

Held in the hand or in your side coat pocket, you can tune in the local broadcasting stations. No bothersome antenna, no external batteries are required.

HAVEN'T you often wished, when hearing an expert describe a World Series baseball game, a football match or a prize-fight over the air, that you could listen to that same vivid description while actually sitting in the stands watching the action? An accurate analysis of each play—the names of the players involved—who caught the ball, who made the tackle, or where the punch landed?

You can do just this with the Pocket Sportset described here! It will fit into your coat pocket and makes a great little companion. It will serve you at sporting events, on the water, on camping trips, etc. Toss it in your suitcase or slip it in your pocket whenever you go away on holiday or business trips. It will always attract attention and provide you with the means for making many interesting experiments, besides its every-day practical uses or applications.

THE SIDE VIEWS

Below: The left and right external views of the Sportset, showing the phone tip jacks, the "on-off" switch, the loop antenna and the two tuning knobs.

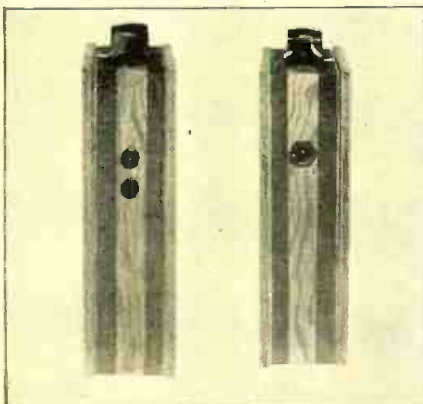

How To Pocket

(For the World Series,

Here is a little set that anyone can around the office among the RADIO many hundreds of them will be built set for major sports events and for works like a charm and

By A. J.

OF course the idea of a pocket receiver is not new, nor is there anything unusual about the super-regenerative circuit. Combinations of this type have been described since the early

days of super-regeneration, which first made it possible to obtain tremendous power sensitivity from a single tube. The writer owned a somewhat similar portable receiver over ten years ago, using two UV-199 tubes built into a small vanity case.

More recently several small pocket receivers of this type have been described by Walter Van B. Roberts.

This latest type of super-regenerative receiver has not received the popularity it deserves; probably because its many practical uses and simplicity of construction have not been realized by the majority of radio fans. The forms in which they can be built are almost endless; while the circuit is so simple and the parts so few that few technical difficulties are ever encountered.

The case for the Pocket Sportset may be built in any form desired, limited only by the constructor's imagination and ingenuity. The model illustrated here was made from 1/4-inch, 3-ply wood, which is advisable, if wood is used, to prevent warping. It is fastened

together with glue and brads. The small partition which segregates the batteries is 4 inches long and placed 1/8 inch on the tube side of the center line.

The inside dimensions of the box are 7 inches by 3 3/4 by 1 3/4. This is about as small as is practicable, if standard parts are to be used, without undue crowding. The front and back covers can be allowed to project about 1/8 inch beyond the sides to protect the loop antenna, which is wound around the sides in two sections.

The Loop Antenna

The loop consists of 56 turns of No. 32 single-silk-covered, enameled-copper wire; 28 turns being wound on each side. The ends of the loop pass through small holes drilled in the case adjacent to their connecting points. The loop tap, which connects directly to the rotor of the tuning condenser, is taken off between the variable condenser knobs.

This form of super-regenerative circuit is designed to oscillate at two frequencies. It operates on a somewhat different principle than the well-know self-quenching circuit, so commonly used now for ultra-high-frequency reception. Its operation is similar to the separately-quenched circuit, except that only one tube is utilized; this tube being made to oscillate at the frequency of the received signal and at the same time at another lower quenching frequency,

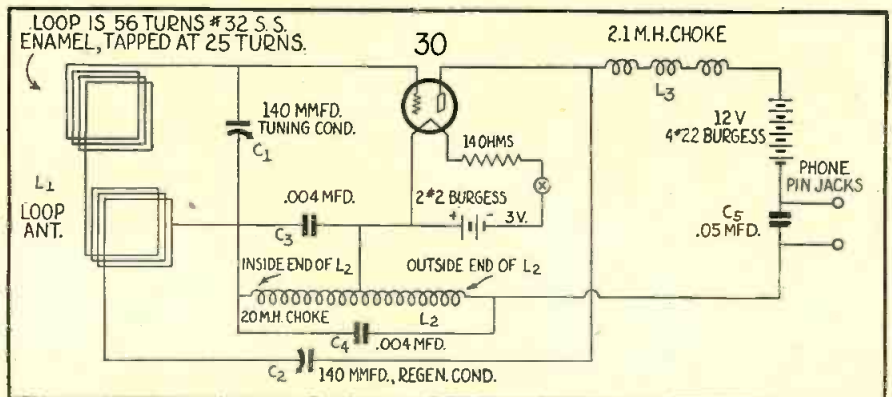

Build a Sportset

for Football, Camp, etc.)

enjoy. Already, it has made a hit NEWS staff. And we predict that by those who want a small portable use in out-of-the-way places. It with plenty of volume, too!

Haynes

just above audibility (beyond hearing).

The signal-frequency oscillation is varied by means of the tuning condenser C1, while the quenching frequency is adjusted by the proper balance of the tapped choke L2 and its fixed tuning condenser, C4. If a constant audio squeal is heard it indicates that the L2, C4 combination is too large and should be reduced, either by using a lower capacity condenser or by removing turns from the choke L2. This choke, L2, which is not particularly critical, is best purchased in the form of a close-wound universal choke of about 20 M.H. inductance, tapped about 1/2-way from the inside (about 1/3 of the inductance). For best sensitivity the condenser, C4, should be as large as possible without causing an audio squeal. The value of all the fixed condensers in this circuit vary to some extent with different layouts, but the given values should be about right. It may be well to try varying the position of the loop tap for the best regeneration control.

Low-Cost Design

Current for the filament is supplied by two of the large, single-cell flashlight batteries such as the Burgess No. 2. If good batteries are used their life will be surprisingly long as the filament current of the 30 tube used is only .06 amps.

The 14-ohm resistor shown in the filament circuit can be easily made by winding some fine insulated copper wire on a small dowel or resistor form until the proper resistance has been reached. If you have no ohmmeter your radio store or any serviceman can wind it for you in a few minutes. Or a section of an old rheostat can be employed. The "B" or plate-circuit battery consists of four "pencil type," 2-cell, flash-light batteries (Burgess No. 22). As these are 3-volts each, a total of 12 volts is obtained when they are connected in series. The circuit will operate satisfactorily with only 3 batteries or 9 volts but there is room for the extra battery and 12 volts gives a little added improvement in volume and sensitivity.

L3 is an ordinary pie-wound 2.1 m.h. choke and is held in place by passing one of its leads through a small hole in the partition beside it; its other lead connecting directly to the plate terminal of the tube socket. The latter should be one of the small molded sockets which were so common a few years ago. If you haven't one in the "junk box" most any radio

store will probably be able to produce one, and several manufacturers still make them (I.C.A. No. 2480). The placement of (Turn to page 249)

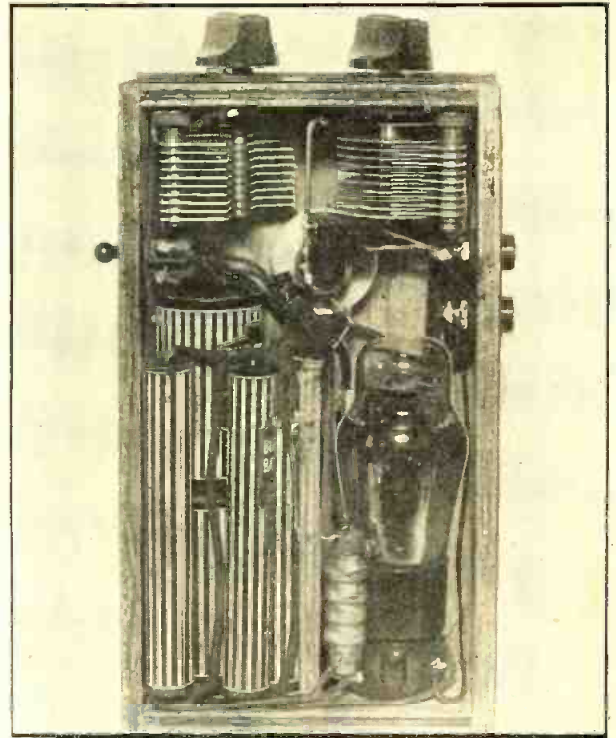

AS COMPACT AS IT IS USEFUL

This view, with the cover removed, gives all the details for constructing the Sportset. It can be wired in half an hour.

Television Range Extended

By John Strong

TELEVISION field coverage tests conducted jointly by the Radio Corporation of America and its subsidiary—the National Broadcasting Company—have proven exceptionally satisfactory to

participating engineers. The programs on the current 441-line definition are clearly and consistently received as far as 69 miles away, as verified by receiving stations as (Turn to page 239)





LEARNING ABOUT A.C.-D.C. RECEIVERS

The average beginner does not readily understand the functioning of the a.c.-d.c. set until the theory and application is fully explained to him.

IF an a.c. receiver, such as the one described in previous *Beginners'* articles, were connected to a d.c. line the power transformer would burn out. This is so because the transformer, possessing inductive reactance, offers a much more difficult path for alternating current than for direct current. Thus, when connecting the receiver to a d.c. line, too much current will flow (some 20 amperes or more), which will burn up the primary. In addition, the receiver will not work, because a steady current flowing in the primary will produce no e.m.f. in the secondary. A sudden surge will be induced only at closing and opening of the switch.

SINCE radio tubes require d.c. to operate, a receiver to be connected to d.c. lines only has very simple power circuits. The 110 volts can be connected directly to the plates through a small filter, which is to take out line noises due to commutator brushes. The filaments of all tubes are generally connected in series and require a dropping resistor if their combined filament voltage is less than 110 volts. A typical power supply for d.c. receivers is shown in Figure 1. Such receivers require that the plug be correctly inserted so as to make the plates positive, otherwise the receiver will not work. A reversed plug will not do any harm unless the receiver employs electrolytic condensers.

A. C.-D. C. Design

When such a d.c. receiver is connected to a.c. it will generally not be ruined, although electrolytic condensers and the speaker cannot stand this abuse very long.

These facts brought about a demand for a receiver which could be connected

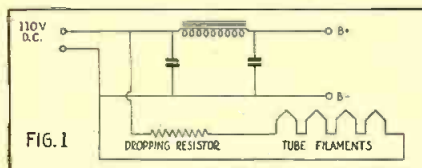

FIG. 1

to either the a.c. or d.c. line without making any wiring changes and which would perform satisfactorily on both sources of supply. Such receivers were

made available several years ago and have enjoyed wide popularity. This article will explain their actions, peculiarities, advantages and disadvantages.

Starting with the filament supply, the filament of the newer tubes can be operated either from a.c. or d.c. Thus, for an a.c.-d.c. set they can simply be connected in series including a resistor as shown in Figure 2. When this is done, it is necessary to choose tubes which require the same filament current if complicated circuits are to be avoided.

Line Resistors

The tube manufacturers have now provided a complete series of tubes all requiring 0.3 ampere. The ordinary voltage amplifiers need only 6.3 volts per tube, but some of the rectifiers and power tubes need as much as 25 volts each. The voltage across all the tubes in series will probably not be equal to 115 volts and this remainder must be taken up in a series resistor. Since this resistor usually becomes very hot and the receiver is small, it is often placed outside of the receiver proper. One favorite way is to include the resistance in the line cord. Such standard cords for different numbers of tubes are available from resistor manufacturers. Another favorite way of solving the problem is by the use of special ballast tubes.

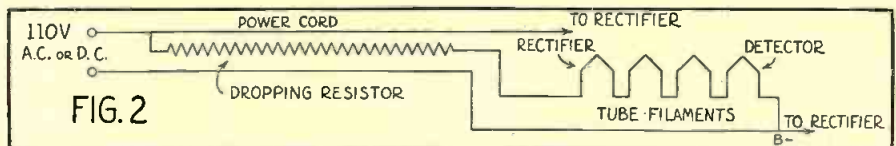

FIG. 2

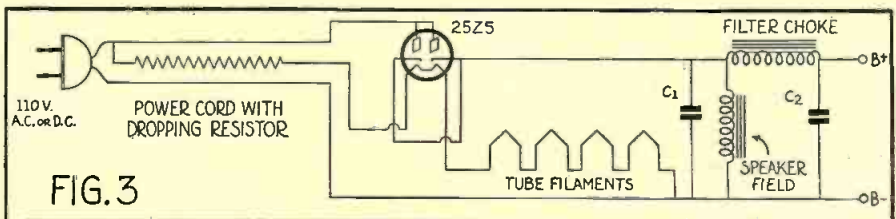

FIG. 3

When arranging the tubes in series it makes a difference in what order they are placed because there is a potential difference between cathode and filament, which varies with the position of the tube. This results in some leakage and hum which should be kept to a minimum for certain tubes, especially the detector. Therefore, the detector filament should connect directly to one side of the line; the side that will become B—.

The Power Circuit

Figure 3 shows the power circuit of an a.c.-d.c. set with the plate supply added. When connected to a.c. the rectifier will conduct only during the half cycle when the plate is positive. The circuit is then completed through the filter choke and the various plate circuits of the tubes. Note that the cathode of the rectifier tube becomes B+. The negative terminal of the B— supply is the other side of the line. This is half-wave rectification which creates a ripple frequency of 60 cycles instead of 120 cycles as in full-wave rectification.

Filtering Hum

Lower frequencies are harder to filter. In order to get the same hum reduction as on 120 cycles, the filter choke must have twice the inductance and the filter condensers twice the capacity. The voltage obtained at the cathode may be over 115 volts, because during the peak of the cycle the condenser C1 charges to nearly this peak value (1.4 x 115 volts), the actual voltage depends on the voltage drop in the tube, the total current drawn and the size of C1. Larger size condensers (*Turn to page 250*)

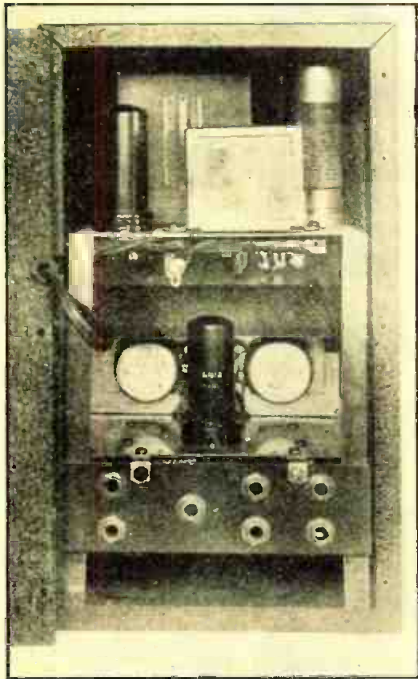

Electronic Signal Mixer

(5 Sources)

By Gerard J. Kelley

THERE are times when the p.a. man or the amateur wishes to mix signals from two different sources or wishes to change over from speech to c.w. and back without having to make a multitude of special connections or varying the volume.

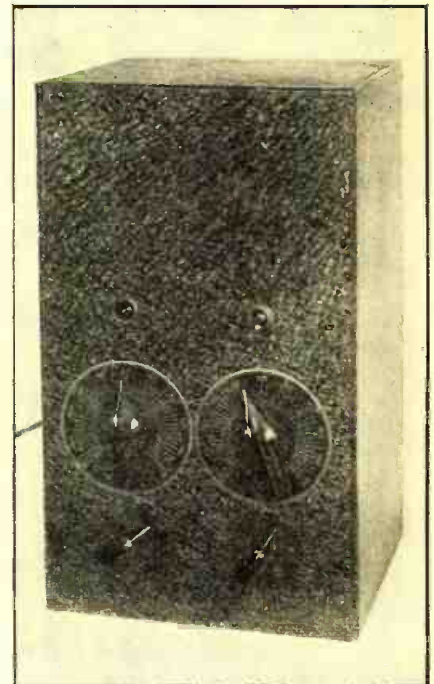

THE electronic mixer described here is a device which permits the connection of any one of four sources additional to the regular crystal microphone while providing facilities for mixing two of them. The output also provides wide variation, allowing connection to a 500-ohm, 200-ohm or high-impedance line. All this is accomplished by the use of a twin-triode, the 6N7, as shown in Figure 1. The grid of one of its triodes is connected to one input jack employing a high-resistance volume control. This is intended for a crystal microphone which is assumed to be the standard microphone in use. The grid of the other triode connects to either one of four possible input circuits having one volume control to serve for all cases. The four input circuits are: a tube (radio tuner or c.w. oscillator or pre-amplifier), a phonograph pick-up and two low-impedance lines which may be either 500 or 200 ohms. The switching is accomplished by two multiple switches rather than one so as to keep down stray pick-up in the high-impedance circuits.

Maximum Flexibility

The output connections provide for a 200-ohm or 500-ohm connection or the jack can be wired directly to the primary of the output transformer, providing high-impedance connections. It

was not the intention to provide any amplification in the unit; the tube serves mainly as mixer and has low amplification.

All input and output circuits terminate in jacks, because it was considered the fastest system for changing connections. It is recommended that all available input devices and circuits be supplied with their own shielded jacks and shielded leads. Thorough shielding is essential when the equipment is used with high-gain amplifiers. In fact, the whole construction and wiring should be done with reduction of noise and hum pick-up in mind.

Transformer Position

For the sake of economy, chrome shielded transformers were used instead of the expensive line. These are less effectively shielded and require mounting at a critical angle. The illustration shows the input and output transformer at the bottom of the assembly—far from the power supply which is on top. Both of these are mounted at critical angles. Connect the output transformer in the circuit with flexible leads. Set both volume controls to zero and connect the

mixer to its following amplifier. Find the position for minimum hum in the final amplifier. Then do the same with the input transformer. Set R1 to zero, R2 to maximum and set S1 to point 1—extreme left position in Figure 1. Then find the best position for T1. Those who wish may substitute the better shielded transformers which will probably not need critical placing.

The back of the volume controls should be connected to the shaft by means of a wire, so as to avoid hum pick-up. Also, a shield should be placed between power pack and volume controls. All circuits carrying the signal, should be wired in shielded braid, keeping connections very short. All ground connections are provided with wires which ground to the chassis at but one point.

Good Grounding

A good connection should be provided between the chassis and the various parts of the metal cabinet, removing the paint at the point of contact between chassis deck and front panel, between the front panel and the box proper, between the back (Turn to page 238)

CONSTRUCTION DETAIL

The circuit diagram below and the three views shown in the illustrations give the reader a clear idea of how this unit can be constructed in a small shielded cabinet.

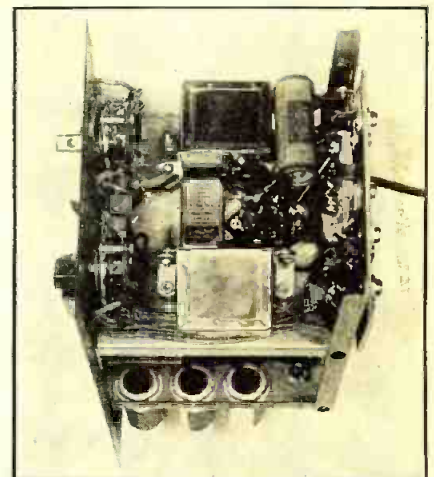
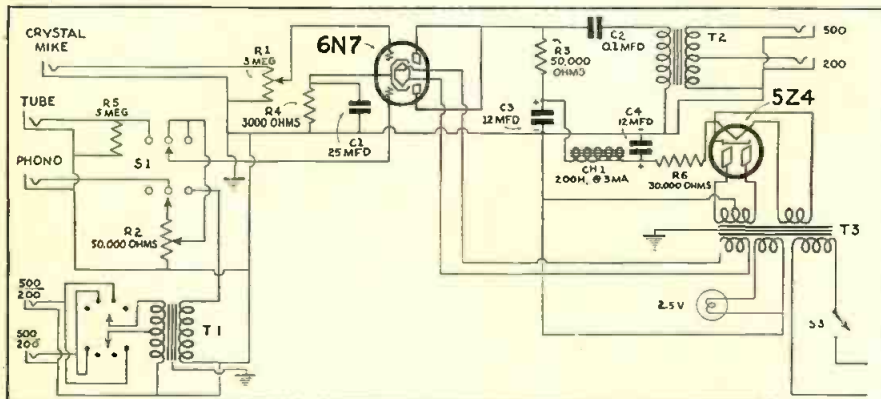

The HAM SHACK

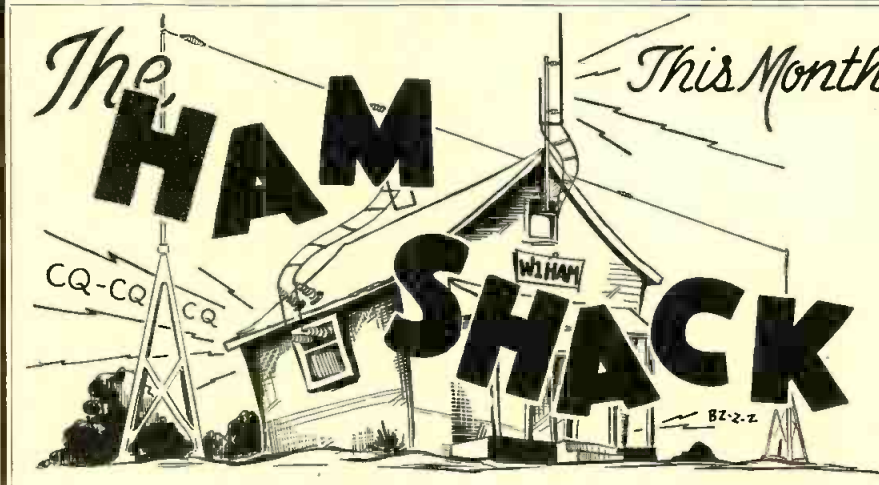

This Month:

- Transmitter Adjustment
- Tuning Up Process
- Antenna Coupling Methods
- Amateur QSL Cards
- The U-Beam Antenna

Conducted by
E. M. Walker
Editor for Amateur Activities

Operating the All-Band Transmitter

THE 4-tube transmitter described in this department last month has proved to be far more effective than expected in tests at the writer's station. As indicated by the construction details presented last month, it is an extremely compact unit. The entire radio-frequency portion is contained in a cabinet 8 by 8 by 14 inches, and matches the modulator cabinet of the 5-meter transmitter described by the writer in the April issue of RADIO NEWS.

AFTER completing construction of the transmitter, as told last month, it is now ready for adjustment and operation. One thing important to the successful operation of the unit is that the correct voltages should be applied to the respective plates, grids and screens of the tubes employed. The plate voltage of the oscillator tube (the 6C5) should not be more than 250 volts and the plate current should be maintained at about 12 milliamperes. This is adjusted, of course, by means of the voltage tap for this tube on the voltage divider. A good high-resistance voltmeter is extremely helpful in making these adjustments.

Full voltage from the power supply is 425 volts. It is the same unit as described in the April issue for the "Sure Fire" 5-

meter transmitter and consists of a United transformer, a swinging choke, a smoothing choke, and two 600-volt electrolytic filter condensers. The rectifying tube is an 83. The whole unit is mounted in a chassis 7 by 10 by 2 inches and is equipped with a power switch in the primary circuit. A 4-wire connector links the power supply to the transmitter. Two of these are for the filament voltage, two for the high voltage.

A socket and cable-socket plug facilitate connecting the two units. In addition two terminals have been provided for connecting a switch to the power supply. This was done so the plate power may be cut off without turning off the filament power. These two terminals are connected to the high-voltage center-tap of the transformer so that it is necessary to short-circuit them in order to obtain plate voltage. A switch or relay switch may be connected across these two terminals to turn on the plate power when it is desired to transmit.

Plate Voltage

Returning to the adjustment of plate voltages, it will be found that not more than 300 volts will be needed on the plate of the 802 buffer-doubler tube. This will

provide more than sufficient excitation to the two 807's in the final amplifier stage. By using the resistors recommended in the schematic wiring diagram published last month, voltages for the grids should be correct. The 802 requires a control grid (grid No. 1) bias of minus 60 volts. It is operated as a tetrode, so the voltage on grids No. 2 and No. 3 is the same. This is obtained through a dropping resistor and should be around 100 volts positive

The Final Stage

The full 425 volts is applied to the plates of the 807's. This drops to 400 when it

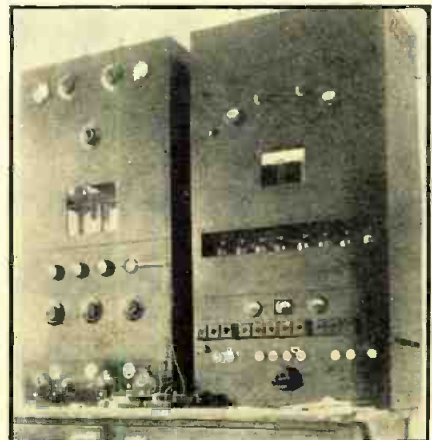

SWEDISH HAM "Veri"
Observer Yoshimura sends in the verification card, below, and photograph, at right, of SM5SX, who works amateurs on 14 megacycles and at times broadcasts on 11.705 megacycles.

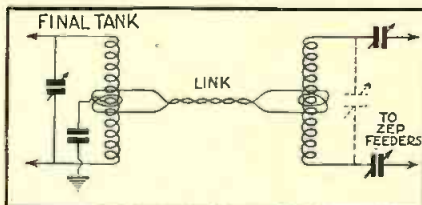
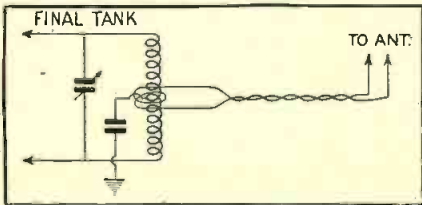

ROYAL TECHNICAL UNIVERSITY, STOCKHOLM
SWEDEN

RADIO DX SY, *Shokichi Yoshimura* 11,705
WE HAVE RECEIVED YOUR REPORT CONCERNING OUR MC/S
DC TRANSMISSION ON 18th Aug. 1936 AT 19.23-22.50 GMT

SM5SX

RECEIVER 10-TUBE SUPERHET	TRANSMITTER CRYSTAL-CONTROLLED PLATE-MODULATED 204-A IN FINAL STAGE	ANTENNA 2 A E-W 400 W OUTPUT <i>O. R. ...</i> <i>K.T. ...</i> OP.
---------------------------------	--	--

MANY THANKS AND 73

Q A Department for the amateur operator to help him keep up-to-date

passes through the modulation transformer. Voltage for the screens is obtained by means of the dropping resistor connected in series with them and the plate tank-coil. This method of obtaining the screen voltage is essential because to have the stage function linearly when modulated it is necessary to modulate both the plate and the screen simultaneously. A condenser is connected across this resistor for by-passing the audio component.

Tuning Up

To set the transmitter in operation, first, all the coils and tubes are placed in their respective sockets. The choice of coils may be determined from the coil table, and will depend on the frequency of the crystal and the frequency on which the transmitter is to be operated. The oscillator coil should be for the band of the crystal frequency. If the 802 stage is to be used as a straight buffer, its coil as well as that for the 807's should be in this same band. If the 802 is to function as a frequency doubler, the coil, of course, should be for the band next highest in frequency. The coil on the amplifier preferably should be for the same band as the coil that is used in the buffer stage. This practice simplifies operation and results in greater output. However, the 807's are excellent doubling tubes, and almost as much output may be

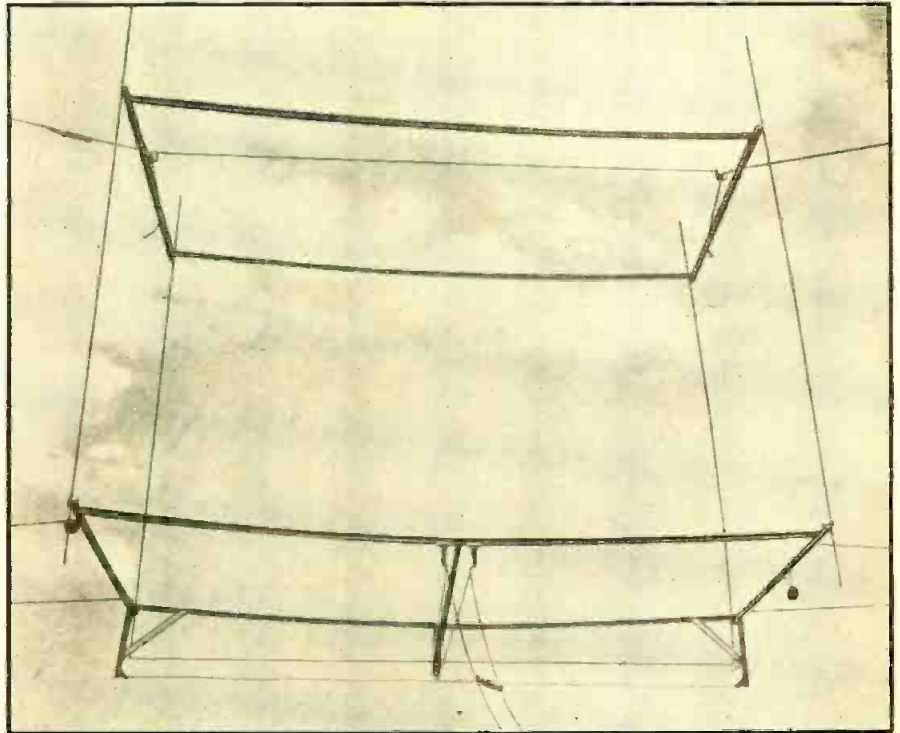

EFFICIENT 5-METER ANTENNA

Above: The Eddystone 5-meter U-beam projects a signal very strongly in a single direction.

obtained when using them for doublers (i.e., when the plate circuit is tuned to twice the frequency of the grid circuit) as straight amplifiers.

Tuning up the transmitter is simple. The plate voltage should be cut off the final amplifier by opening the modulator terminals and cut off the buffer tube by removing the buffer plate coil. Then the 0-25 milliampere ammeter should be plugged in the oscillator plate jack and the oscillator tuning condenser adjusted until there is a decided dip in the plate current. This will indicate that the circuit is oscillating. As a further check a 1-watt neon lamp may be held near the plate coil of the oscillator
(Turn to page 242)

A BELGIAN STATION

At left: The Ham Shack of Adrian Blancquaert, ON4KD of Belgium, who works many American amateurs.



New
U-Beam Antenna
for Five Meters
By Robert Ames

A NEW antenna for 56-60 megacycles operation has recently been designed by Eddystone which is finding considerable popularity in Great Britain. From its shape it has been called a U-beam antenna.

The U-beam antenna consists of two half-waves in phase, $\frac{3}{4}$ wavelength apart, Hertz-fed with a $\frac{3}{4}$ -wave matching section which in turn is fed by a $\frac{1}{2}$ -wave matching section at its center. Two $\frac{1}{2}$ -wave reflectors, shown at the front in the photograph concentrate the beam in approximately an
(Turn to page 243)

WEST INDIES STATION

At left is the verification card of 1116F which is self-explanatory. Below: F. A. Sanabia, 1116F, with arms folded, and 1111C, Major Falverde, resting on elbow with his son Enrique at center.



SANTO DOMINGO, DOMINICAN REPUBLIC.
Radio Ur sigs wkrd hr at M., E. S. T.
H I 6 F 
QSA QRM Band QRN NOTE WX
Xmitter Rcvr
Vy 73 F. A. SANABIA
Operator

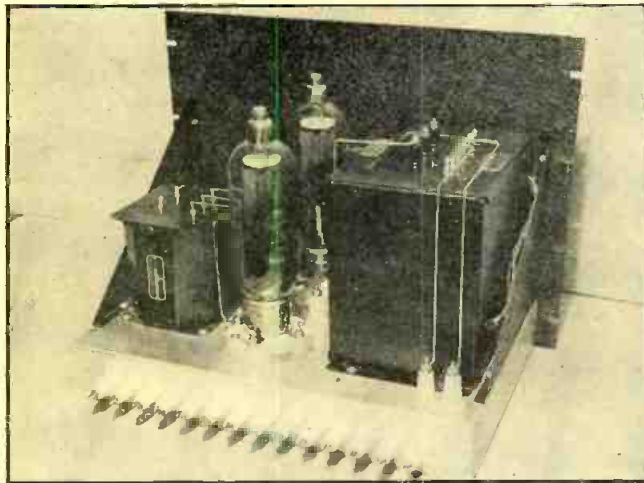

ABOVE AT LEFT: REAR VIEW OF UNIT H. AT RIGHT: THE REAR VIEW OF RECTIFIER UNIT K.

Design and Construction Data on a Modern X'tal-Control Transmitter (The Modulator Unit)

By Willard Bohlen
Chester Watzel
L. M. Cockaday
(Part Three)

THE lower unit, M, of the "Compact Kilowatt," now in use at W2JCY has identical construction with the corresponding unit F in the r.f. cabinet. The only difference is in the wiring, as may be seen in a comparison of Figure 2 and Figure 3. Unit L is also similar to unit E, the only difference, outside of interconnections, being that unit E contains an extra pair of 866A rectifiers and filament transformer for same, these tubes being used for the 1200 volt supply in the r.f. cabinet.

Unit K comprises a complete C-bias supply for the 822 modulator tubes. The violent grid-current excursions of these tubes under modulation conditions is ruinous to the voltage regulation of any but a specially designed bias supply. As the grid-bias voltage on the 822's must be kept constant (or near constant) for minimum audio distortion it is imperative that a bias supply be used that maintains almost constant output voltage with a widely varying load.

The simplest method of accomplishing this purpose is to use a low-voltage,

IN the previous two articles we have covered the general features of the entire transmitter and also the construction of the r.f. cabinet and all its units in detail. The remaining two articles will cover the detailed construction of the a.f. cabinet, speech and control unit N, also the operation of the transmitter. We will begin this third article with a "unit by unit" description of the a.f. cabinet.

high-current power transformer, mercury-vapor rectifier tubes (which have a low voltage drop of about 15 volts)

THE CONTROL UNIT J

At left is the rear view of the modulator control Unit J and at right: The front view of its panel.

choke input filter and a bleeder resistor of very low ohmage. In this particular supply the power transformer is rated at 500 ma.; a pair of 500 ma. filter chokes are used; 48 mfd. of filter is employed, and the bleeder resistor value is only 500 ohms (400-watt rating). This bleeder is mounted on the unit above, J, where the output voltage may be easily adjusted. This low-ohmage, heavy duty bleeder accomplishes two purposes. First, it imposes such a heavy load on the bias supply that the grid-current excursions of the 822's are low in comparison. Second, these variations in grid current produce a negligibly small variation across the low resistance of this bleeder.

Unit J is the control unit of the a.f. cabinet. It is quite simple in comparison to the corresponding control unit C in the r.f. cabinet. This is natural as the a.f. cabinet contains but one audio stage and two power supplies. The only filament transformer in unit J is T-4, which supplies 10 volts to the 822's. R4 is the filament-control rheostat for these tubes, and is controlled (*Turn to page 247*)

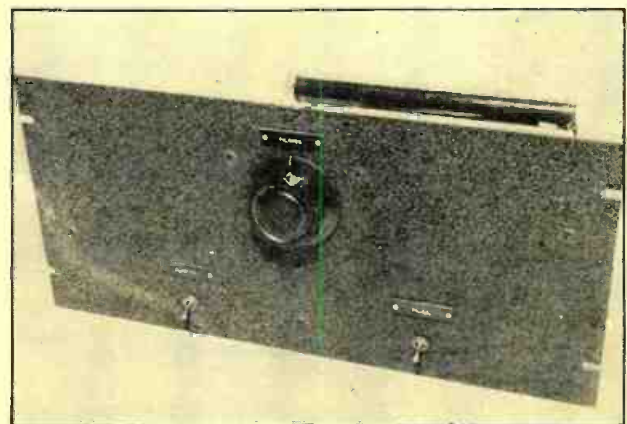
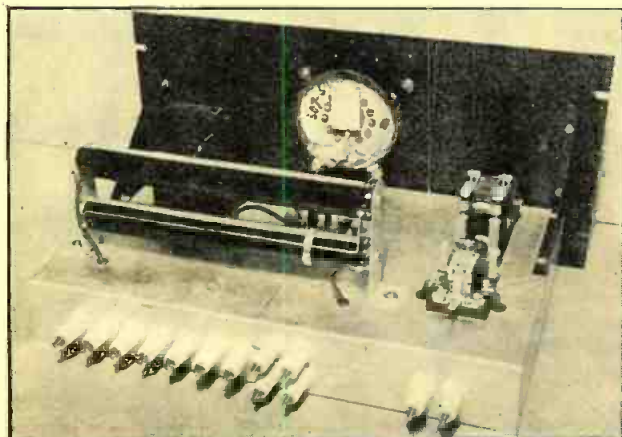
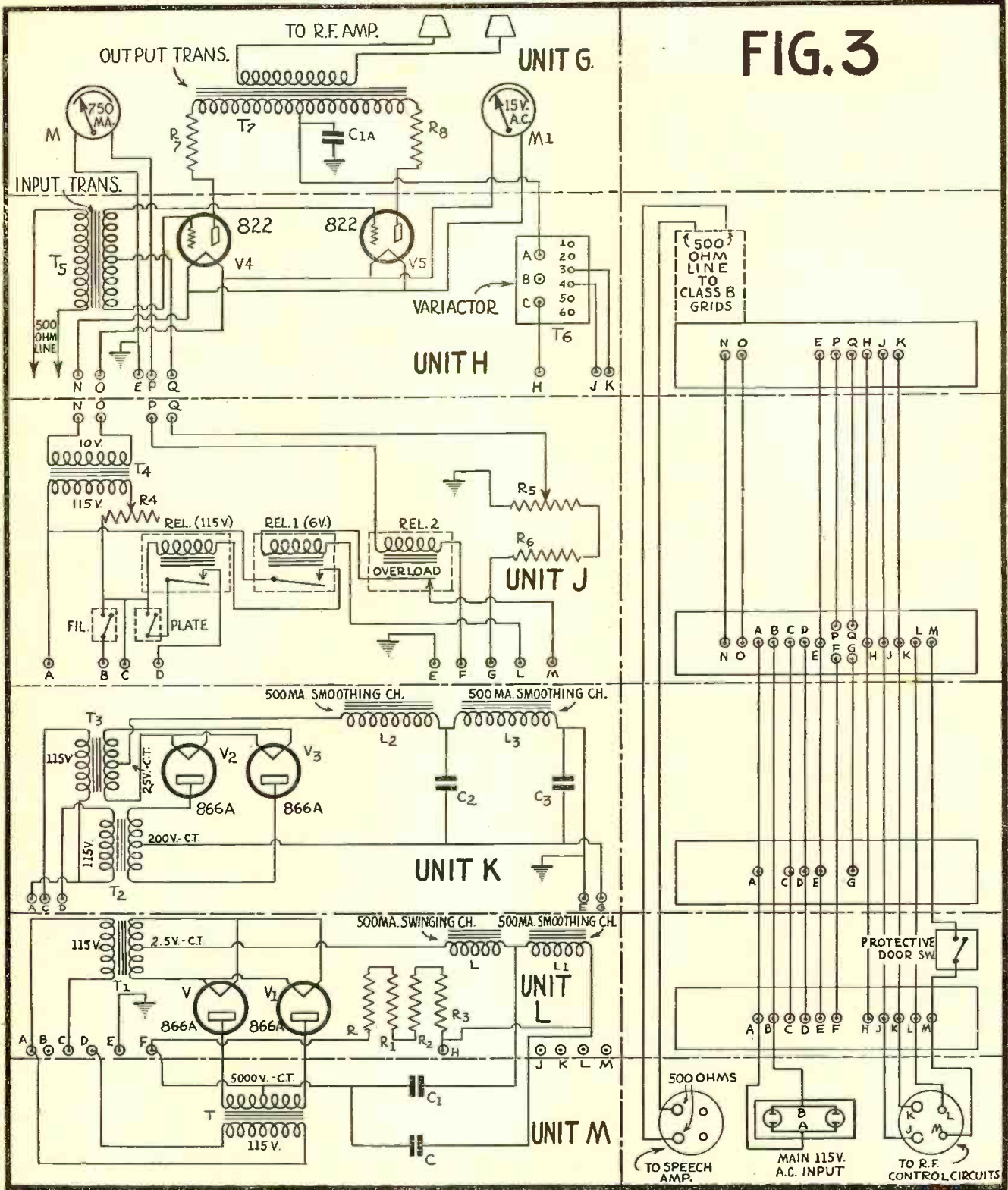
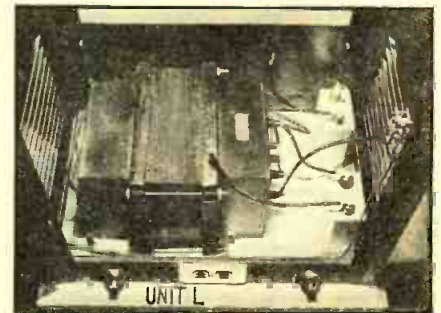
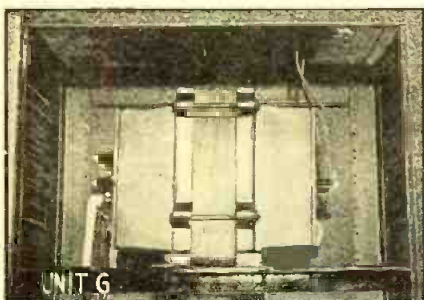

FIG. 3



ABOVE: SCHEMATIC CIRCUIT. BELOW: A VIEW OF UNIT G AND TWO VIEWS OF UNIT L.



RECEIVING STATION
South Africa
 SARL
 THIS CONFIRMS QSO ON 14 MC ^{FIVE} AT 100 HOURS GMT DATE 16 OCT 1935
 Your Signal: MUC. APPRECIATED MW TX Clean Steady
 RECEIVERS SIX TUBE S.S. AND McMURDO SILVER EIGHT S.S. WITH XTAL FILTER.
 TRANSMITTER OSC BUFFER AMPLIFIER CLASS B MODULATOR
W. H. BROWNING. SOUTH AFRICA
 WALLACUS, P.O. 1068

AN FB "VERI" FROM SOUTH AFRICA

Official S.W. Observer Albert Emerson of Cleveland received this card verifying a report he submitted to ZU6E covering contact between this station and W1AJZ.

THE AMATEUR OBSERVER
Conducted by W2JCR

ONCE more a cordial invitation is extended to those who listen extensively on the amateur bands, to send in their applications of appointment as Official Radio News Amateur Band Listening Post Observers. To do this, send in a list of the calls you have heard during the previous month, listing them by districts, countries and bands and wherever possible including "R" reports. Include a little information about yourself and the equipment you use and state that you would like to be an amateur observer. Certificates will be awarded to all who are appointed as official observers.

THIS department will appear each month hereafter and it is hoped it will serve a very useful purpose both in letting listeners know what is being heard on the "Ham" bands and in letting "Hams" know whether their signals are being heard.

In sending in lists of stations heard, please do not include any "local" signal. Just what is meant by "local" will, of course, vary with the different bands so the listener reporting will have to use his own judgment on this point.

5 and 10 Meters

Main interest at W2JCR, which is operated portable at Fairfield Beach, Conn. during the summer, and W2JCY at North

Pelham has been concentrated on 5 and 10 meters during the past month. During this period the behavior on both bands has been abnormal. The 5-meter band has been far more open than during the previous summers. Past experience indicates that we should have several "open" periods during the summer, lasting usually for two or three days at a time. This summer, however, the band scarcely opened up at all until early in July and it has been continually open since that time. At no time has it been open in a spectacular way such as May 9th and July 4th, 1936 when the 8's and 9's really rolled in in bunches, but contacts of 100 to 200 miles have been daily occurrences.

The 10-meter band has been rather unusual in that the skip appears to be increasing earlier than last year with the result that real DX is expected to arrive considerably earlier. Moreover, it appears that the 10-meter band has been open more frequently and for longer periods than was the case last year.

It would be interesting to have reports from stations in various parts of the country concerning conditions on the 5-meter band this summer. It may be that the conditions as experienced around New York have not held for other sections of the country. In fact, such is quite probably the case. In any event, it would be worthwhile to compare notes.

It is undoubtedly true that the 5-meter equipment employed both for transmission and reception is improving all the time. This could account for some of the improvement noted this summer but not all of it by any means because many of the stations participating in regular contacts over 100 miles are still employing "wobulated" oscillators and super-regens. There can be no question, however, that crystal controlled rigs and good superhets—especially those equipped with noise limiting circuits—are providing far more consistent results than the older types of rigs.

DX Corner for the Broadcast Band

THE DX Corner for Broadcast Waves is being omitted this month because of the very limited interest of readers in DX activities during mid-summer. The department will be resumed in the November issue.

Calls Heard

By W2JCR (Portable), S. Gordon Taylor
Fairfield Beach, Fairfield, Conn.
5 meters ("Quartet" Superheterodyne):
W1J1-9, W1KEG-7, W1DEI-5, W1JLK-9,
W1G11, W1GDI-9, W1MY-8, W1JNX-9,
W1DO-8, W1JEC-6, W1JZI, W1ZE-9,
W1FKV-8, W1JNX-8, W1JIS-9, W1HT-6,
W1KCS-9, W1BAD-9, W1JIS-5, W1YT-6,
W1JGA-9, W1KPN-3, W1CGY-5, W1BCR-9,
W1A1-7, W2BCC-9, (Mobile, Orange, N. J.),
W2EGM-8, (Mobile, Upper Montclair, N. J.),
W2FBI-7, W2GEJ, W2HEJ-9, W2HNZ-7,
W2IQO-8, W2IRY-8, W2IYN-9, W2IZP-8,
W2JGF-6, W2IZB, W2RB (Marine, Gt. South Bay, L. I.), W2BNH-8, W2DSY-8, W2GAH-9,
W2HVN-9, W2CRT-7, W2EKI-9, W2GFS-8,
W2DTG-9, W2EJP-7 (Mobile, Springdale, L. I.), W2JTP-9, W2JRG-9, W2AMN-8, W2IZ-7,
W2HGB-9, W2BCC-7, W2BHD-7, W2MS-9,
W2CNS, W2DKI-9, W2IAG-8, W2KLV-7,
W2CPZ-8, W2HYK-9, W2IQO, W2IZE,
W2VD, W2ISV-8, W2DTH-7, W2JNX-9,
W2KCH-8, W2KGF-9, W2ICK, W2KNZ,
W2IKD-6, W2JZN-6, W2JRN-9, W2SB-9,
W2JJI-7, W2JZW-9, W2HG-8, W2DPB-8,
(Mobile, Rutherford, N. J.), W2EJP-7 (Mobile 30 miles northwest of N. Y. C.), W2KPN-3,
W3AFJ-7, W3DOD-7, W3EZM-7, W3GLF-7,
W3FSX-8, W3QGQ-6, W3BFB-9, W3BZJ-7,
W3AXR-8.

By W2JCY, Laurence M. Cockaday, North Pelham, N. Y.

5 meters ("Quartet" Superheterodyne):
W1KPN-9, W1AUK-9, W1J1-9, W1KNN-8,
W1ZE-8-9, W1JIS-8, W1BAO-9, W1GDI-9,
W1EER-9, W1FHN-9, W1AVV-9, W1BCR-9,
W1DEI-9, W1DBM-9, W1COO-7, W1KSD-8,
W1JML-8, W1EYM-9, W1KOK-9, W1JPM-8,
W1JLK-9, W1JQA-8, W1KEG-8, W1KFL-5,
W1JXP-7, W1FKV-8, W1JIZ-7, W1MY-8,
W1CCD-5, W1JRN-8, W1DXK-7, W1BDM-6,
W1HDO-5, W1ADR-7, W1KQ-7, W1CK-8,
W2GAH-9, W2IKD-8, W2JJI-9, W2EJP-9,
W2ST-9, W2HNN-9, W2KAN-8, W2KPP-7,
W2GXN-6, W2FCQ-7, W2HWN-9, W2GFS-8,
W2GPP-9, W2RB-9, W2KDC-9, W2JQE-8,
W3GLF-9, W3BZI-8, W3EKT-8, W3CQG-9,
W3EZM-9, W3BFB-9, W3AC-9, W3EPN-8,
W3AFJ-8, W3ANU-9, W3DZD-9, W3DO-8,
W3HG-6, W3FVR-9, W4EDD-2, W5EHM-4,
W8QWQ-9, W5FZE-8, W5HIP-7, W9UAQ-8,
W9GKZ-3.

10 meters: W1KPP-7, W1JIZ-8, W3GGC-4,
W3GYJ-5, W4EDD-9, W4GB-7, W4DXM-8,
W4ETF-9, W5GAR-8, W5CQI-8, W6OZH-7,
W8QMF-9, W8COB-7, W8NZU-9, W9EKD-8,
W9ETF-8, W9JL-9, W9JL-8, W9WXT-8,
W9WCX-8, W9YRN-9, W9RN-9, W9TII-9,
W9UNT-8, W9EKD-8, W9UPX-7, W9UDQ-9,
W9WED-8, W9AC-9, W9EKT-7, W9ZFF-9,
W9UIA-8, W9LUWY-6, K5AT-9, K5AG-9,
T12RC-8, HK1JD-9, HR4AF-9, VK2GU-6,
K6MNV-7, LU7AZ-8, G2ZY-4.

20 meters: SU2TW-7, CX2BK-3, U3JS-5,
D4CSP-8, OZ5H-9, FPSPB, G5ML-8, G6ML-8,
G5OG-4, D4HNG-6, LU9AF-5.

By N. C. Smith, "Somerset", 53 Birch Tree Road, Petts Wood, Orpington, England

10 meter phone: W1DQK, W1WV, W1COO, W1CHV, W1BJE, W1BQQ, W1JOW, W2BQK, W2BAA, W2GJK, W3FVO, W4FC, W4EBM, W7BQX, W8BHM, W8HSP, W8EIO, W9BAT, W9BPU, W9BHC, W9TTB, W9PZ.

10 meter c.w.: W5EHM, W5DQ, W6CNW, W6DOB, W6CSI, W6KIP, W6FZL, W6HB, W6JLU, W9TPI, W9HRK, W9TIF, W9JFB, W9GVL, W9HFK, W9GRV, W9ZT, W9OT, W9QVI, W9ROB, W9OWU, W9JDP, YV5AP.

20 meter phone: K4SA, K6AIA, W5COO, W5BEE, W6AM, W6CQI, W9DRS, W9AXH, W9PPP, W9VAQ, W9EIL, O4IAL, OZ3H, YV1AA, YV4AM, YV3AK, YV5BU, YV5ABE, U8BX, VO4A, VO6L, VP5CT, VP6YB, VP9R, CNSAA, CO2RY, CO2QQ, CO2MA, CO5RY, CO7CN, CO8OG, CT1AY, VE3EO, VE4JV, SU1HG, SU1CH, VK2XU, VK2TI, FT4AL, VS2AK, PY2EI, PY2BA, PY3AW, SV1KE, SM5VW, SM5QV, HA3B, LA4R, LY1J, HK3AA, HJ5ABE, CN1AB, CN1AA, CE1AR, CE1AO, LU2CA, LU4BL, LU6KE, LU7AZ, LU7BK, LU8AB, H15X, H17G.

75 meter phone: W1DBZ, W2GEE, W3FVQ, W3BI, W3BOJ, ON4HS, VE1CR, VO1J, VO1P.

By P. Piorko, E. E. Sienkiewiczza 9, Lodz, Poland

20 meter phone: W1AJZ, W1BLO, W1GCZ, W1DLO, W1HPV, W1FH, W1DIC, W2IKY, W2JKQ, W2HWU, W2GVN, W2CVV, W2BZ, W2IW, W3MD, W3DIL, W3AKE, W3LN, W3ACO, W3FA, W3NII, W4CVU, W4DAA, W4EL, W4DSY, W4DCR, W4DRD, W4BAZ, W4GW, W4EJA, W6AM, W8GLY, W8NSF, W8RL, W8CTC, W9BCY, W9OLY, VE1DR, VE1JA, VE1AR, VE1DQ, VE1DC, VE1LR, VE2BR, VE2BG, VE2AA, VE3Q, VO1Q, TI2NR, TI2RC, K4SA, CO2WY, CO2HF, CO2AY, CO2AG, CO2RR, CO2MT, CO2HS, CO5VS, HP1A, XE2AR, XE11Y, XE11I, PY1EW, PY2EI, PY2ET, PY2FF, PY2BA, PY5QI, LU1DE, LU2KE, LU4KA, LU4BL, LU8AN, LU5CZ, LU6KE, LU6EW, LU6EA, LU8AB, LU8EN, OA4R, OA4N, YV1AA, YV5AE, YV5AK, HK3JK, HK3JA, (Continued on page 256)

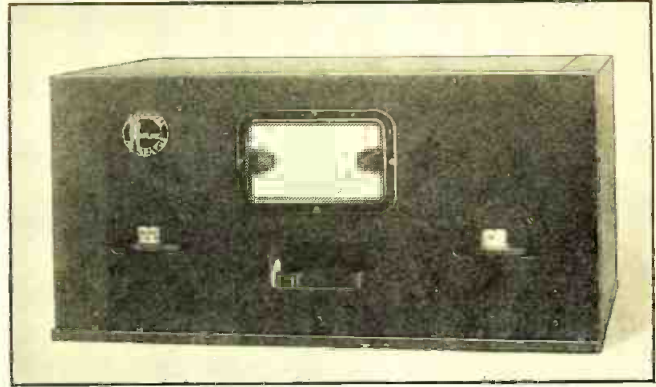
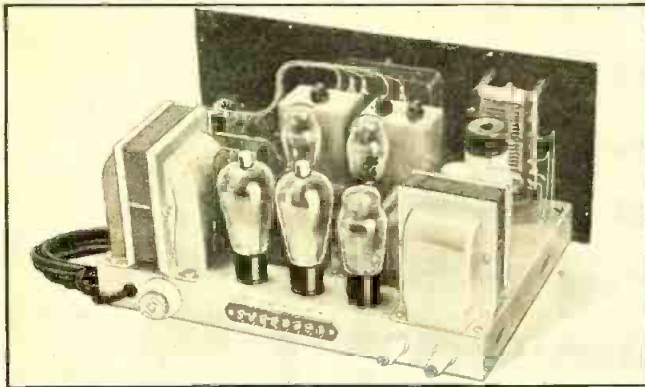

ABOVE: THE REAR AND PANEL VIEWS OF THE NEW MONTGOMERY WARD, MODEL OR-5, R.F. UNIT

Ready Built

10-160 Meter Transmitter

for Amateur Use

By Everett M. Walker (W2MW)

(Part One)

THE coming of many new tubes simplify the adjustment and operation of a transmitter. The pentode, because of its design, requires no neutralization—a feature which makes it highly desirable. Eliminating the need for neutralization eliminates one of the most difficult adjustments in a transmitter.

Phone and C. W.

A transmitter which makes use of such tubes, as well as many other interesting features of design and construction, recently was announced by Montgomery Ward & Company, as the OR-5. This transmitter is designed primarily for the amateur who has a liking for c.w. operation, yet occasionally likes to operate on 'phone. While it uses only two tubes in the r.f. portion, it will deliver to the antenna more than 60 watts on c.w. on all bands from 28 to 1.8 megacycles, and on 'phone provide a 15 to 20 watt carrier that may be 100 per cent modulated with a very small and compact external modulator unit.

The transmitter itself is entirely self-contained except for small biasing batteries and the telegraph key. It is

THROUGH the introduction of transmitting tubes with low excitation requirements, it now is possible to design an all-band amateur transmitter that will give a fair amount of output with only two tubes in the radio-frequency component. This has been brought about by the application of the highly efficient pentode principle to larger transmitting tubes.

mounted in a cabinet 19 by 12½ by 9 inches. The circuit, Figure 1, employs a 6A6 oscillator doubler unit which drives an RK-20 tube in the final amplifier. The power supplies for both the oscillator and amplifier are contained in the same cabinet. A low voltage supply which uses a 5Z3 rectifier supplies the plate voltage for the oscilla-

tor-doubler; a high voltage unit which delivers slightly more than 1000 volts and uses a pair of 866 tubes as rectifiers, supplies the plate and screen voltages for the RK-20.

Many interesting features are incorporated in the transmitter's design. Principal among these is the novel plug-in oscillator-doubler unit which may be tuned for a given band and crystal and inserted in its proper position without the necessity for readjusting the unit each time it is desired to change from one band to another. This facilitates band changing.

Plug-in Unit

These oscillator-doubler units are complete units in themselves. They consist of the oscillator coil and its associated tuning condenser; a doubler coil and associated condenser; socket for the crystal and socket for the 6A6. The whole unit is mounted in a compact metal case that is equipped with a nine-prong rectangular plug mounting. Two receptacles with plugs in the corresponding positions are contained on the chassis in which the completely shielded unit may be inserted. As may be seen from the schematic (Turn to page 243)

R.F. CIRCUIT DIAGRAM

Figure 1 shows the schematic circuit for the r.f. exciter unit. At left: The modulator cabinet for the transmitter.

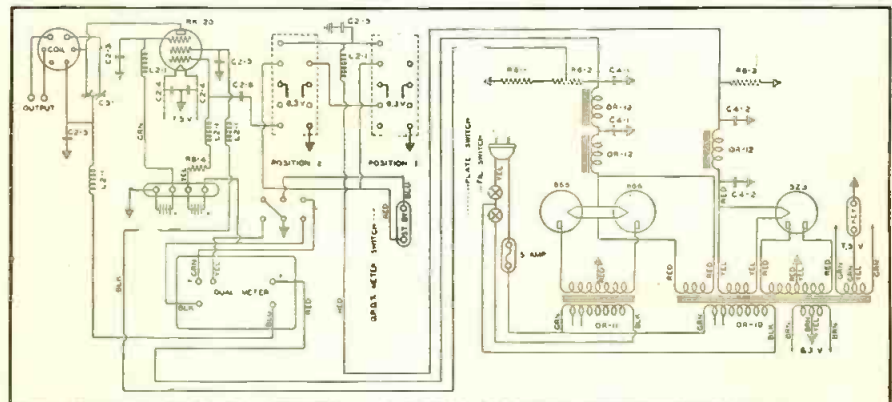
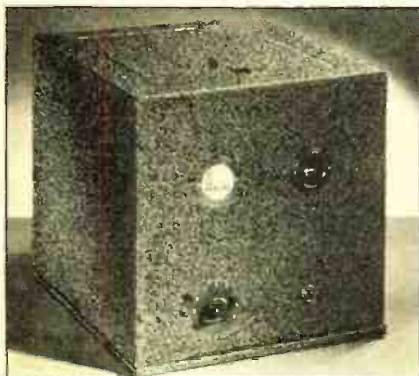

The RADIO WORKSHOP

Items of interest for beginners, experimenters and radio constructors.

Conducted by William C. Dorf

A Combination Table Lamp And Code Practice Set

This code practice set built into a table lamp is both useful and novel. It is simple to construct and takes a minimum of parts, most of which are to be found in any experimenter's junk box.

There are no batteries to renew. The power for operating the device is obtained from either 110 volts alternating or direct current.

A 25-watt light bulb is used as the dropping resistor to give the correct filament voltage to light the 201A tube used in the audio oscillator. Employing the lamp idea, the heat that is ordinarily wasted in the dropping resistor is turned into useful light of normal brilliance.

The code practice oscillator is mounted in the table lamp base. Two wooden blocks, fastened together, form the base; one is 5½ inches square and the other 4½ inches square. Both are ½ inch thick. The larger bottom block extends out from the top block ½ inch on all sides. Three metal uprights ½ inch wide and 1½ inches high are mounted on the base and are used as supports for the can. The audio transformer, 201A tube and socket are housed inside the can. Fahnestock clips are then fastened to the rear corners of the wood base, two being used for the headphone connections and two for the practice key.

Small cutouts are made in the rear of the can next to the two sets of clips to

allow wires to be run through and connected. A hole faced with a rubber grommet is made for the lamp cord, also one for the switch which is placed in the center of the rear side of the can. These attachments and connections are then invis-

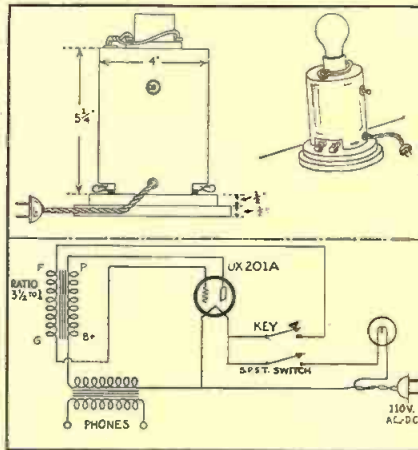

ible from the front, giving no clue as to the dual use of the table lamp.

A standard porcelain type lamp socket is fastened to the top of the can and the shade fastens directly to the bulb. The can and wood base are then enamelled to suit.

P. M. OHLINGER,
Portsmouth, Iowa.

Home-Made Knobs

The bakelite and composition bottle caps used extensively for drug store preparations make excellent push-on knobs for radio sets, measuring instruments, etc. The first thing to do is to take a small piece of very light gauge tin and bend it around the shaft on which the knob is to be used. The tin spring or form for the shaft is removed and compressed slightly to insure a snug fit when finished. It is then placed in the center of the cap, held firmly and then melted sealing wax poured around it. When the wax is hard the knob is ready for use. Caps in all the different sizes, colors, and shapes improvised into knobs in this manner lend distinctiveness to the tuning controls of the receiver.

D. E. DOBRNSKI,
Springdale, Ark.

A Special Radio Tool

Conventional design of soldering irons has always dictated a handle which is parallel to the iron proper. Now we have the "Pistol" type soldering tool, the first

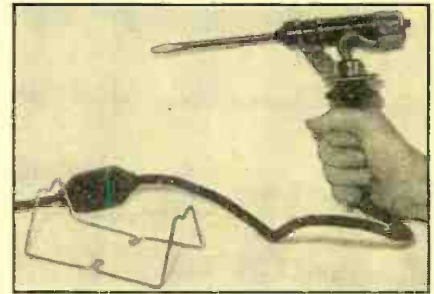

actual advance in soldering iron design in recent years! Never before was a soldering iron designed specifically for repair work on a radio receiver, but one has now been announced by Supreme Instruments Corp. as conceived by veteran service engineers for this special purpose.

The photograph shows the new working comfort which results from perfect mechanical balance, attained by mounting the handle of the iron at right angles to the heating body. Due to its pivot mounting, the heater portion may be set at any angle from approximately parallel to 110 degrees with the handle, thereby allowing additional flexibility to meet all working conditions.

Its non-scaling copper soldering rod may be extended up to a full six inches from the heating body proper, making it easy to reach locations which are completely inaccessible with straight soldering irons. Moreover the rod is extendable in either direction by loosening a set screw and either end of the soldering rod may be used by simply turning the tool around in the hand. This allows the serviceman to have a different type point at each end, either being available instantly for use.

The soldering rod proper is easily removable for pointing and shaping, and additional rods may be obtained in a variety of shapes or can be bent by the serviceman, himself. Three "heats" are controlled by a special 3-position switch on the cord.

The three heats available are: 75 watts for general light work, 150 watts for medium work, and 225 watts for quick heating and for heavy duty soldering. A special heat-insulating material is used between the heating unit and the handle so that the handle remains cool under all conditions. The tool is supplied with a 5-foot asbestos insulated cable and comes in both triple and single heat models. Its weight is only 18 ounces.

SAMUEL C. MILBOURNE,
Greenwood, Miss

Tests in the R. N. Laboratory provide convincing evidence of this new tool's practical utility, both for general use in radio work, and especially for working in close quarters under a chassis.

Homemade Chassis Cradle

I find that in servicing a radio receiver (Turn to page 255)

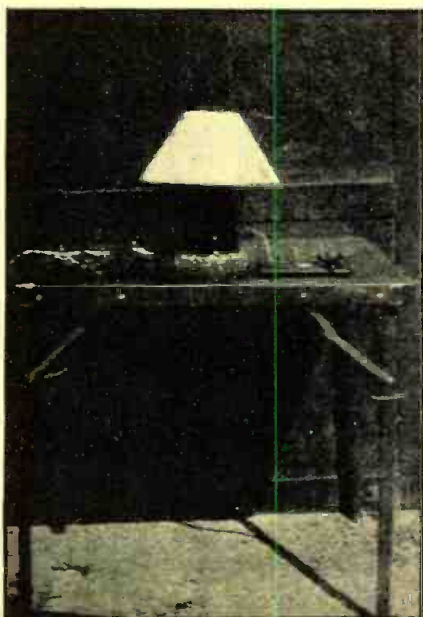
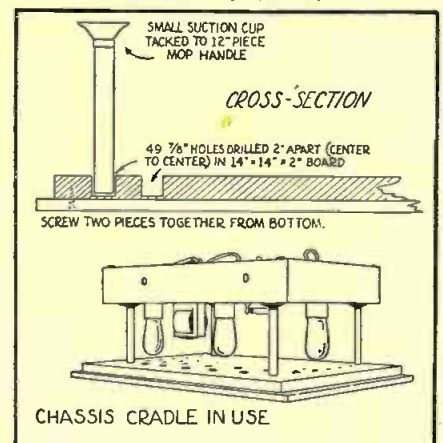

Design Features of the New "Masterpiece" 21-TUBE Receiver

(Silver Masterpiece VI)

By McMurdo Silver

(Part One)

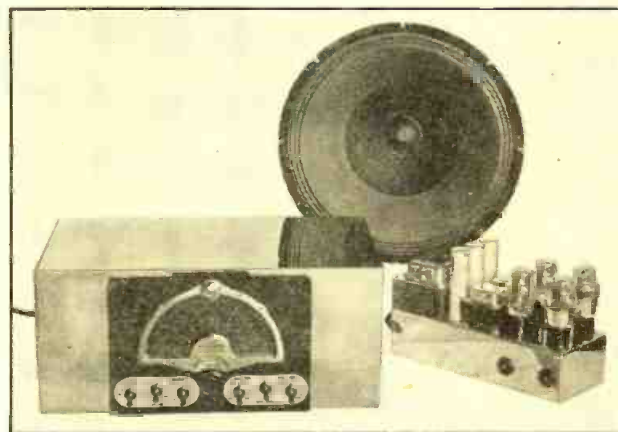

THE NEW 4.287 TO 2150-METER RECEIVER
21 tubes are employed in this new circuit which features
real high-fidelity, selectivity variation by a new method,
full-tone range control and dual a.v.c., as well as per-
fected volume expansion.

IN a year of new models in which the technical advances in broadcast receivers are most noticeable by their absence, except for different forms of automatic tuning for lazy broadcast band listeners, the new Masterpiece VI should prove unusually interesting. In this 21-tube receiver (140 to 70,000 kc.) are found a number of both major and minor technical advances.

THE new Masterpiece VI is similar in general appearance to its predecessor, and has in fact developed out of the Masterpiece V the excellence of which is proven, to cite but two instances, by its choice by the Bowdoin-Kent's Island Expedition for both communication and broadcast reception, and by its use by the present leader in a world-wide international DX contest who holds over one hundred verifications of stations heard, all over 6,000 miles distant.

Flexible Design

A complete description of the new receiver is impossible, both for lack of space and because each receiver is individually custom-built for its specific owner, so that two are seldom exactly identical. Each owner may specify and obtain the characteristics and performance he desires, limited only by sound engineering. The basic design has been engineered in so flexible and complete a manner that the buyer may have super-sensitivity, super-selectivity, extraordi-

narily pure and complete tone, or practically anything he desires. Such flexibility and the complete combination of supreme DX ability in a receiver which at the same time is the choice of world-famous musicians is most unusual, for herein one set is both a superb communication and DX receiver and an amazingly fine musical instrument.

Starting upon the assumption that the straight line is always the shortest distance between the two points of maximum results and absolute dependability, extensive research and laboratory analysis were undertaken to find just how few tubes could be used to give championship results. In a fine receiver all the trouble the user should expect is tube deterioration with use and the fewer tubes that can be used the smaller the possibility of trouble, and the lower the initial and operating costs. In the block diagram, below, are indicated the progression and functions of the 21 tubes to which the design was finally reduced after the research work was finished. Two 6K7 tuned r.f. amplifiers may be used, or switched out for extreme high fidelity, from 140 to 19,000 kc., but are omitted in the band from 19,000 to 70,000 kc., where losses increase in r.f. amplifiers with ordinary tubes. One of the new features lies here—variable r.f., as well as variable i.f. selectivity. To avoid compromising the sensitivity and selectivity of the two-stage r.f. amplifier, the fidelity control cuts it out of

circuit when its extreme selectivity would impair high-fidelity reception. Such a clean-cut and new system completely avoids the circuit impairment which may not be avoided in any attempt to directly vary r.f. stage selectivity and enables the r.f. amplifier to be operated at maximum sensitivity and an entirely new order of selectivity. This high r.f. gain in selectivity, coupled with quite low and variable i.f. gain, accounts in large measure for the extraordinary freedom from tube and circuit noise.

Stabilized Oscillator

The 6J7 oscillator is electron-coupled to the 6L7 first detector and employs an automatically-stabilized circuit both for frequency stability and to insure the constant output voltage so essential to uniform sensitivity without "dead spots" appearing in each wave-band. Careful design of the oscillator circuits and functioning attains extraordinary constancy and stability over widely-varying a.c. line-voltage ranges and enables the discarding of auxiliary voltage-regulator tubes.

Following the first detector comes the first tuned and amplified a.v.c. system using a two-in-one 6B8 tube as amplifier and rectifier. This a.v.c. system (more accurately, automatic sensitivity control, since it controls volume through automatically adjusting sensitivity to optimum for every signal) operates only on the r.f. and first detector tubes to hold their gain at maximum for all signals less than strong enough to overload these tubes and cause distortion and loss of selectivity. It is valuable in permitting reception of weak stations next to the super-power stations, since this separate r.f. a.v.c. system prevents overload and loss of selectivity on super-powered local stations.

The optionally two or three-stage i.f. amplifier, changed by the fidelity-switch knob to vary selectivity and sensitivity as desired, is an entirely new system. Really three separate i.f. amplifiers instantaneously selected for each reception need, it is a completely new approach to the whole i.f. amplifier problem. Fundamentally this problem is that with i.f.

(Turn to page 238)

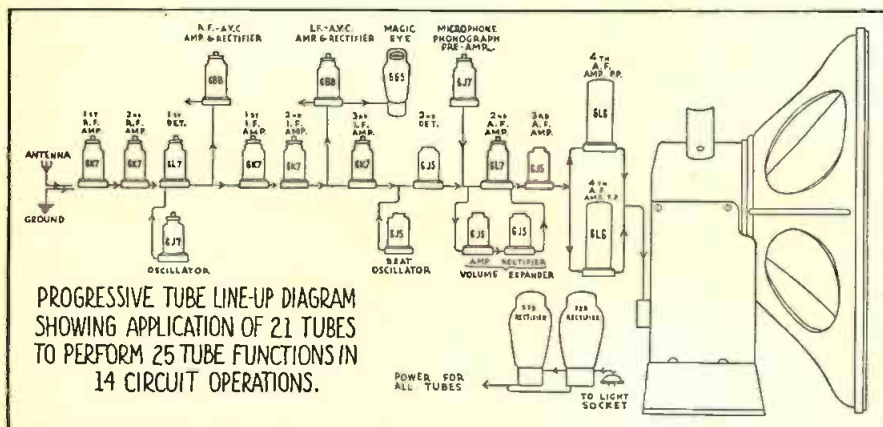

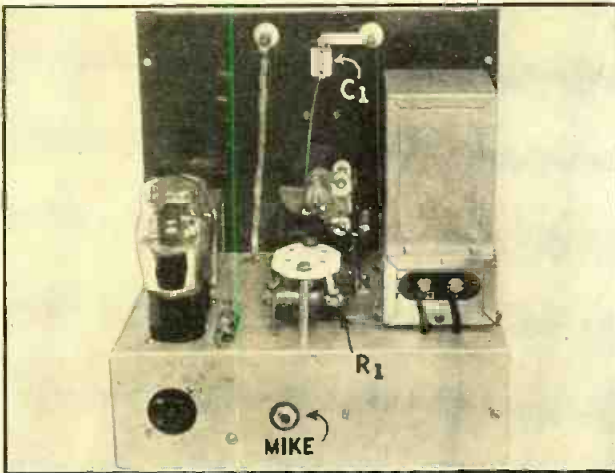

A COMPLETE TRANSMITTER

The new "Vibrapak" vibrator supply shown at the right of the chassis provides 300 volts at 100 milliamperes—ample for both the transmitter and a receiver. All operating power is drawn from the car battery.

WHILE there is nothing startlingly new about the design of this "Tiny Tot" transmitter, it is a well-trying and proven line-up which has become noted for its consistency and ability to "get out" under adverse conditions. An earlier example was described by Arthur H. Lynch (W2DKJ) in the October, 1936, issue of RADIO NEWS. It is easy to tune up and permits the operator to QSY quickly when necessary—often an important consideration in portable-mobile work when you are on the move.

THE A battery drain on this transmitter is only about 10 amperes under full load. This is about the limit that can be tolerated for practical operation from a car battery. The 45-2A5 combination used here has several points in its favor:—In the first place, of all the receiving tube family, the old reliable 45 is probably our finest 5-meter oscillator when it comes to handing out a good "sock" for a given input. The 2A5, when 300 volts is available, as it is here, will turn out a good solid five watts of audio power which is sufficient to do a respectable job of modulating our r.f. input of twelve to fifteen watts.

Another important point which must always be kept in mind in mobile work is the voltage drop from the storage

THE CHASSIS LAYOUT

The tuned circuit is laid out to provide short leads and correspondingly high efficiency. At the left are the modulator and speech amplifier tubes, the latter included to permit full modulation without having to shout into the mike.

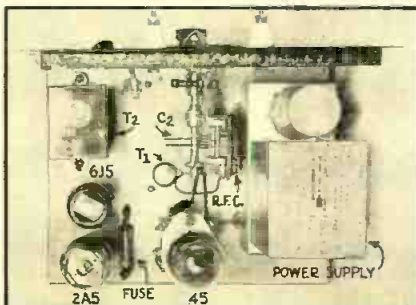

something left over and can tolerate any reasonable drop in the line, as far as the tube filaments are concerned; although if you expect maximum output from the high-voltage supply you will use nothing less than No. 14 wire from the battery and No. 12 is desirable if the transmitter is located in the rear of the car.

Finally there is the question of impedance match: The 2A5, as we are using it, should have a resistance load of 7000 ohms which means that 43 ma. plate current at 300 volts gives us a perfect match with 13-watts input to the oscillator. The 2A5 will draw about 50 ma. plate and screen current and as the Mallory "Vibrapak" used power supply is rated at 100ma.-300 volts, everything comes out right on the nose after a few milliamperes are deducted for the 6J5G speech amplifier tube.

Ultra Audion Circuit

If there is such a thing as a fool-proof 5-meter circuit it is certainly the ultra-audion. With the exception of the grid-leak return it is the same circuit employed in the "Tiny Tot" receiver. It is simple to tune and efficient. The only thing that will stop it oscillating is too much antenna load. This is controlled by the small trimmer in the antenna

Amateurs! You
"TINY TOT"
for Portable—

Here is a 5-meter portable-mobile a companion for the "Tiny Tot" be a suitable companion it had to of tests it has lived up to

By A. J. Haynes

circuit. The latter is mounted directly on back of one of the stand-off insulators so that it can be adjusted with an insulated screw-driver through the small grommet in the panel.

A jack is provided for plugging an O-100-ma. meter in series with the plate circuit of the oscillator when tuning up. This jack must of course be insulated from the panel and chassis.

There is nothing unusual about the modulator and speech amplifier. These tubes, with their associated resistors and condensers, are located as far as possible from the power supply, the modulation transformer being placed on top of the chassis next to the speech amplifier where it is well away from the fields of the other transformer and chokes.

The Filament Circuit

Note the 10-ohm resistor across the filament of the 45 tube. This is necessary to equalize the voltage distribution between this tube and the 2A5 as their filaments are in series and the 45 draws only 1.5 amps. while the 2A5 requires 1.75 amps. As there is a difference of .25 amp. at 2.5 volts the 10-ohm shunt equalizes this exactly.

The only debatable question in this transmitter—and this applies to all mobile rigs—is what to use for current supply to the microphone. The Tiny Tot receiver was equipped with pin jacks for the microphone terminals and supplied

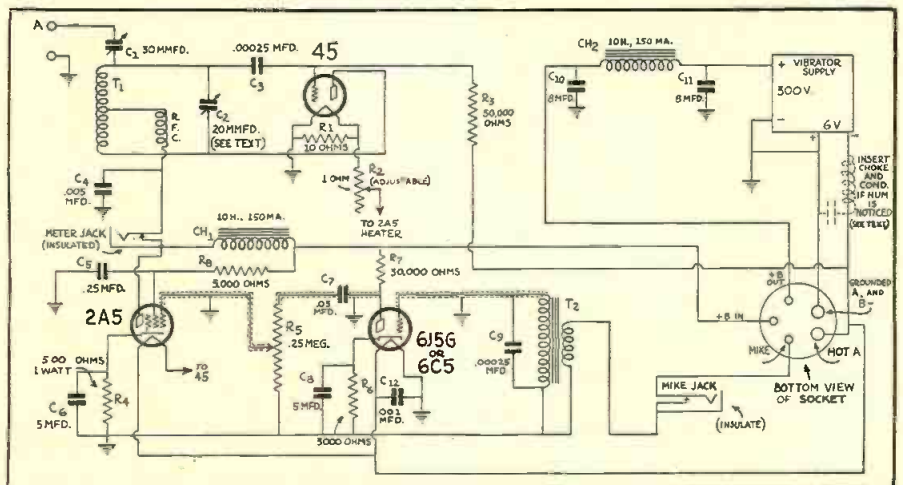

Can Build This X'MITTER

Mobile Usage

transmitter which was designed as receiver described last month. To be good, and after a thorough series expectations beautifully.

(Radio W2JHV)

microphone current through a by-passed dropping resistor across the voltage supply from the storage battery. This arrangement has only one drawback. It creates a good deal of hum on the carrier, regardless of what type of high voltage generator is used, unless the "hot" lead from the storage battery is filtered. This is easier said than done as we cannot afford much voltage drop in this circuit. If you can obtain a laminated core from an old medium sized choke or transformer a satisfactory filter for this purpose can be made by winding about twelve turns of No. 12 enameled wire on it and inserting it in the "hot" 6-volt lead to the transmitter as close as possible to the latter but separate from it. This lead is then by-passed to the chassis on the inside by a 1 mfd. non-inductive paper condenser.

Microphone Supply

By far the simplest arrangement is to use a single dry-cell in the microphone line between the receiver and transmitter. When using the separate battery, absolutely no hum was audible on the carrier even when received on a super-heterodyne at a distance of seven blocks (and the carrier was so strong on this test that it blocked the super-regenerative receiver first used). When using a separate battery, the dropping resistor and its by-pass condenser in the receiver are, of course, omitted.

A phone jack is placed in the back of the transmitter chassis. This is a closed-circuit jack in series with the microphone circuit. It permits the microphone to be plugged in directly on the transmitter when testing, if the microphone pin-jacks on the receiver are shorted with a jumper.

Uses Hand "Mike"

A Stromberg-Carlson No. 6 hand microphone is used with this rig and was found to combine high output with unusually good quality and complete freedom from road bump or vibration effects—all valuable assets in mobile operation.

The new Mallory Type VP552 "Vibrapak," synchronous vibrator high voltage generator is used in this transmitter and mounted right on the transmitter chassis

which eliminates a lot of messy wiring and installation headaches. This entire power assembly, which includes the vibrator, transformer and hash filter comes completely shielded, and is mounted by suspending it at four points on the chassis with rubber insulated mountings which are provided with it. The unit assembly is then grounded with a single ground lead to the chassis. The smoothing choke and electrolytic

NEAT AND SIMPLE

The finished transmitter measures 10 by 10 inches and is 8 inches deep. The central dial is the tuning control and above it is the hole for adjusting the antenna coupling condenser. The modulation gain control is at the right and the meter jack at the left.

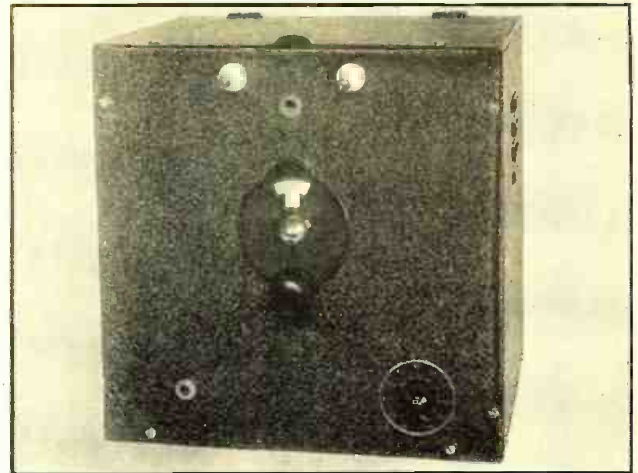

by-pass condensers are placed below the chassis on the power supply side. The modulation choke is also below the chassis.

The use of a synchronous vibrator eliminates the need of a rectifying tube, thus improving regulation, conserving space and, incidentally, reducing the cost. This power (Turn to page 239)

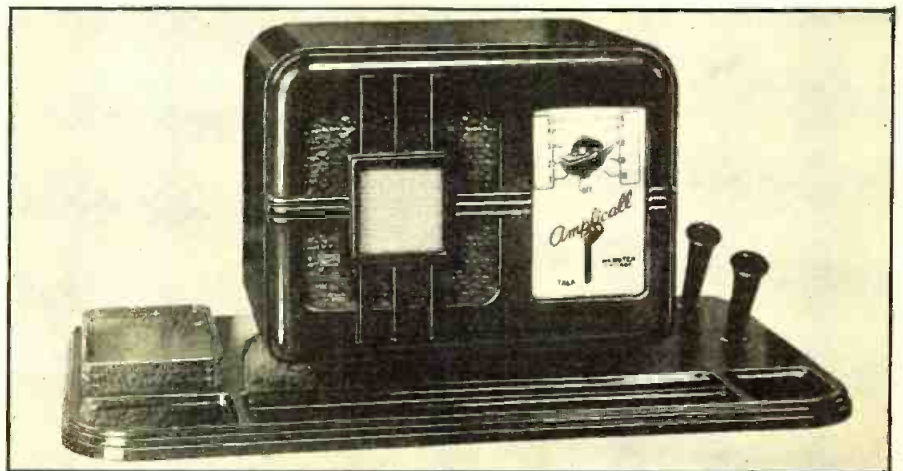

DESK PHONE

Systems

By J. Erwood

METHODS of hooking up intercommunicating equipment to meet a wide variety of requirements are given in this concise article by Mr. J. Erwood, who is Chief Engineer of Webster (Turn to page 249)

MODERN OFFICE UNIT

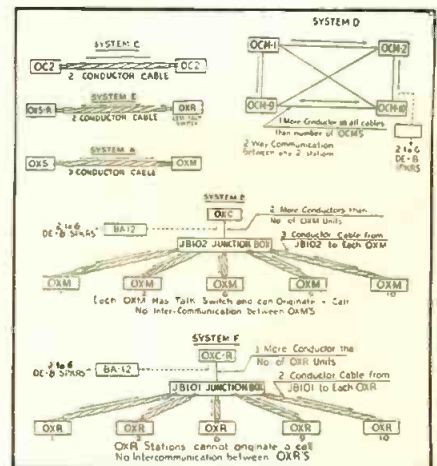



The SERVICE BENCH

COMBINING BUSINESS AND PLEASURE

Figure 5. Combined service shop and amateur station W8FYV. These two activities work out well for this serviceman.

THE SERVICEMAN AND THE AMATEUR

THIS short article is directed to two individuals—the serviceman who is not a radio amateur, and the amateur who is not a radio serviceman. To the former it is recommended that he qualify for an amateur license—ultimately Class A. To the amateur it is suggested that he consider the possibilities of radio servicing as a money-making proposition.

THE possession of a government amateur radio station license and an operators license contributes to the prestige of the serviceman. In some respects it is a more convincing recognition of his radio ability than a certificate of proficiency from some radio school. Anyone can call himself a "radio expert" or a "service engineer," but the passing of a government examination is definite proof of radio capability even if not specifically on service problems. Customers visiting the shop and station cannot help but be impressed by the equipment displayed. The psychological value of such an appeal is well appreciated by servicemen who are licensed amateurs and almost invariably the fact is mentioned in their sales literature

and on their stationery and cards. Figure 1 shows the letter-head of the Searles Radio Service, of Boscobel, Wisconsin, owned and operated by W9CLM. The card of Art Immicke (Figure 2) states that he is a licensed radio operator, while "WSKDT" is prominently displayed on the card (Figure 3) of the Winton Radio Laboratories, Buffalo, N. Y.

A Good Boost!

There is also a practical as well as a psychological advantage to the serviceman being an amateur operator. Regardless of how expert one may be on specific service problems and how well grounded on fundamentals, the additional knowledge necessarily gained in preparing for an amateur examination and later in operating an amateur station cannot help but make a much better serviceman of anyone. An intimate contact with transmitters and transmission problems provides a liberal education in itself and has a definite reflection on receiving problems. The serviceman will have a better idea of what can and cannot be done with radio and will be in a better position to answer the questions of his clients as well as to apply a more intelligent attention to servicing their equipment. At the same time he will develop a more basic interest in radio—radio will become more of a game and less of a labor than ever—and it is only when one's heart is pretty much in his job that one does his best work!

Caters to Amateurs

Figure 4 is a photo of H. W. Brown, first a serviceman who later on took up amateur radio. He is located on Howard Avenue, Tampa, Fla., and his call is W4ELY. He is active mostly on 40 meters c.w. and on 56-megacycle fone. He is advantageously located between a retail ice distributor and an automobile service station—both excellent year-round businesses in the south.

Figure 5 shows the service shop and amateur radio station (W8FYV) of Ralph S. Harrison, Bethesda, Ohio, while Figure

6 is a close-up of the transmitter. Mr. Harrison tells his own story:

"You will note that my Service Bench and transmitter are located in a corner of a room in the house. I do radio service work on a part-time basis, my regular job at present being that of engineer at the Belmont County police radio station. I have been servicing radios for the past ten years. I am a graduate of two radio schools; have had training in radio with the Signal Corps and the Regular Army. I am also a member of the Radio Manufacturers Service.

Unique P. A. System

"I have a 40-watt, high-gain, public-address system for rental purposes. You will note the speakers and the directional baffle horns stored away under the Service Bench. I also use the amplifier of the P. A. system in my transmitter as a speech amplifier and modulator. You will recognize it as the middle shelf in Figure 6. When I want to use it for P. A. work I merely slide it out of the front of the rack, flip a switch at the rear and it is ready to go places! The switch is mounted on the rear of the chassis to cut the high voltage from the chassis when employed in conjunction with the transmitter. I can

Figure 4. Mr. Brown is also a radio amateur.



Figure 2. "Licensed radio operator" means something on your business card. Below, Figure 3. Here the call is displayed prominently and effectively.

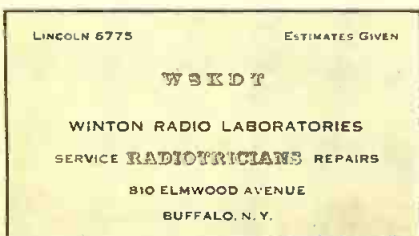

THIS MONTH

The Serviceman and The Amateur . . . Compressed Air Blower . . . Service Kinks . . . Service Sales Promotion . . . Service Notes . . . Service Success Story . . . **SERVICING:** Montgomery Ward . . . Aircastle . . . Peter Pan . . . Golden Bear . . . Radiola . . . Packard Bell . . . Atwater Kent

By Zeh Bouck
Service Editor



Figure 6. The P. A. amplifier is part of this amateur transmitter.

make a quick change with the amplifier from the transmitter when a P. A. rental shows up.

"I use the 1000-ohm side of the output transformer as a modulation transformer in the transmitter and it works exceedingly well. The r.f. stages of the transmitter are composed of a 47 crystal oscil-

A SERVICE BENCH AND SOME HANDY HELPS!

Figure 7. A compressed-air blower made from an old vacuum cleaner; a handy tool on any Service Bench. Note copy of RADIO NEWS and Rider Service Manuals.

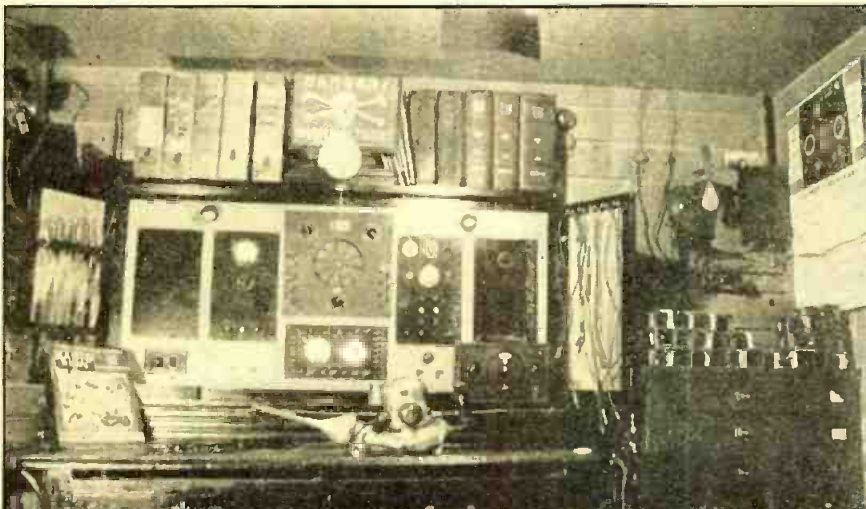

YES!

MY RADIO

NEEDS

YOUR

FREE

INSPECTION

Robertson's Radio Service
4019 Broadway Street
Huntington Park L.A. 8642

Please call and check my RADIO. I understand this service call is ABSOLUTELY FREE and this request places me under no obligation.

Name _____

Address _____

City _____ Phone _____

Make of Radio _____
Call during Day After 6 P. M.

OUR POLICY:—
Free Service Calls in your Home.
No Labor Charge over \$1.00.
All work Guaranteed 1 year.
CREDIT CHEERFULLY GIVEN.

Figure 8. A business reply card that has produced results for Mr. Robertson. The original is in two colors.

lator, a 59 buifer and a 203A in the final, with 750 volts on the plate. I operate fone and c.w. on all amateur bands in accordance with the rules and regulations.

"On the shelf above the Service Bench you will note a stock of Tungsol radio tubes. I also carry a reasonable stock of spare parts. I have built up a nice spare-time service business in the last ten years and I really have more work than I can do. Occasionally, along with my other work, servicing radios keeps me up pretty late nights."

Reversing the Process

So much for the serviceman taking up with amateur radio. As for reversing the process, the radio amateur with his deep interest in all things radio and his excellent fundamental training, radio servicing offers a logical step into the commercial radio field with excellent chances for success beyond mere tinkering with balky radios. All radio amateurs have the place and many of them the equipment, with which immediately to enter a part-time service business.

As in every other field, not every radio serviceman makes a success of radio servicing with expansion into related enterprises. But it is significant that among those who do make a success, there is a large percentage of radio amateurs.

One thing more: While it is perfectly legal and ethical to capitalize upon one's status as a radio amateur in the manner outlined in the previous discussion, care must be observed not to do so more directly, for instance by solicitation of repair work over the amateur fone bands or by constant reference to the fact that you do radio servicing. Your amateur station can be considered as an asset to you personally, but it cannot be commercialized in any way.

THE DAY'S WORK

K. W. Brown, of St. Joseph, Mo., contributes the following kink on a—

Power Blower

"There is many a time when the serviceman can use a power blower, and he can save himself many a trip to the nearest tire station by construction one from a junked vacuum cleaner as suggested in Figure 7 and the following notes: The vacuum cleaner cost me \$1.50. After the handle and other unnecessary parts were removed, the nose of the suction plate was cut off, and a handle formed from spare parts in the junk box and fitted in place. The handle from a discarded electric iron is perfect. The bag ring is left intact, and a funnel—an ordinary tin funnel (of approximately the same diameter) is soldered or otherwise affixed to it. (You won't be able to solder if the bag ring is aluminum.) A short length of rubber hose or tubing is then slipped over the funnel nose, to protect the receiver parts and for flexibility as well as for electrical insulation (against grounds). A toggle switch can be mounted on the motor frame if desired. We have found this bit of equipment very useful dusting the interior of cabinets and the chassis. The blast of wind will reach where the dust rag can't go—and the total cost was \$1.65, plus a little labor."

Aircastle Auto Radio

"The tube sockets in this receiver are not marked, and the serviceman must depend pretty much on inspection and common sense to determine just where the tubes go. However, he is likely to be stymied by the 41 and 75. The grid lead for the 75 comes up between the two sockets and gives no indication into which socket the tube should be plugged. To make matters worse, the socket for the 41 is surrounded with a shield base and there is no shield base around the 75 socket! One would naturally plug in the 75 in the socket having the

(Turn to page 228)

The WIEN BRIDGE

as a Frequency Meter

By W. J. Creamer

THERE are many small laboratories that are unable to maintain elaborate frequency measuring equipment for the audio-frequency range, and yet at times find it desirable to be able to determine with some degree of accuracy a number of test frequencies.

THE use of bridge networks as frequency meters¹ is well known; but for the small laboratory the use of most of these networks is out of the question because of the expensive precision standards of inductance and capacitance required, or because of the errors introduced by stray fields, particularly in circuits requiring mutual inductance.

There is one network, however, the so-called Wien Bridge, which is simple and inexpensive to construct, and which can be used to determine test frequencies with a fair degree of precision provided an accurate reference frequency is available. The reference frequency required need not be of any hindrance, since if no precision tuning fork is at hand, we may use the 1000-cycle modulation from the National Bureau of Standards station WWV. The application of this bridge to the determination of frequency is not new,² but its utility as a semi-precision instrument when used in conjunction with a highly accurate reference frequency has not been sufficiently emphasized.

Figure 1 shows the conjugate circuit of the usual Wien bridge with the detector connected at the junction of the equal ratio arms, an arrangement which proves more convenient with some ratio-arm boxes. Writing the conditions for balance, we have

$$R_1 I_1 = \left(\frac{R_a}{j\omega C_a} \right) I_2$$

$$R_1 I_1 = \left(R_b + \frac{1}{j\omega C_b} \right) I_2$$

Dividing to eliminate the currents I_1 and I_2 , and collecting reals and imaginaries, we obtain

$$\frac{-jR_a}{\omega C_a} = \left(R_b R_c - \frac{1}{\omega^2 C_a C_b} \right) - j \left(\frac{R_b}{\omega C_a} + \frac{R_a}{\omega C_b} \right)$$

Equating reals to reals,

$$\omega = 2\pi f = \frac{1}{\sqrt{C_a C_b R_a R_b}} \quad (1)$$

Equating imaginaries to imaginaries,

$$\frac{R_a - R_b}{C_a} = \frac{R_a}{C_b}$$

or

$$\frac{C_a}{C_b} = 1 - \frac{R_b}{R_a} \quad (2)$$

Now equation (1) shows that R_a and R_b must vary inversely with the supply frequency; but equation (2) shows that if C_a and C_b are unaltered for balances at two different frequencies, the ratio of R_b/R_a must also remain unaltered. Therefore R_a and R_b must both change in the same pro-

portion for balance at two test frequencies. Designating this ratio by the factor K , we may now write equation (1) for two specified frequencies, f_1 and f_2 :

$$f_1 = \frac{1}{2\pi \sqrt{C_a C_b R_a R_b}}$$

$$f_2 = \frac{1}{2\pi \sqrt{C_a C_b K R_a K R_b}}$$

where f_2 is greater than f_1 , and K is larger than 1. Then $f_2/f_1 = K$.

A comparison of frequencies is thus made possible by adjustment of the resistance units R_a and R_b only; and if a standard reference frequency is available, other frequencies may be quickly and accurately determined.

As an example, let us assume that the bridge is in balance for a precision frequency of 1000 cycles with a given set of condensers when R_a is adjusted to 460 ohms and R_b is adjusted to 340 ohms. Then for a 950-cycle frequency R_a should be set at $\frac{1000}{950} \times 460 = 484$ ohms, and R_b should be set at $\frac{1000}{950} \times 340 = 358$ ohms.

Incidentally it may be noted that the values of the condensers are also determined by the 1000-cycle balance; for, applying equation (2), $C_a/C_b = 1 - 340/460 = 0.26$; and then applying equation (1) after squaring,

$$C_a C_b = \frac{1}{4\pi^2 \times 10^6 \times 340 \times 460} = 0.162 \times 10^{-10}$$

Combining these equations, we find $C_a = 0.205$ mfd. and $C_b = 0.789$ mfd.

To illustrate the actual use of this bridge, a Campbell-Shackleton shielded ratio-box³ was employed as a convenient foundation unit. A 0.1 mfd. (nominal value) mica condenser was chosen for C_a and a 0.2 mfd. (nominal value) mica condenser for C_b . For balancing resistance type 4748 Leeds & Northrup decade boxes were used for R_a and R_b . Fractions of an ohm, when required, were added to each unit by slide-wire rheostats.

The reference frequency chosen was the 440-cycle modulation being supplied at the time this test was run by the National Bureau of Standards station WWV. This was received on an all-wave receiver tuned to 10 megacycles; and a laboratory vacuum-tube oscillator, held to zero beat with it, was used to supply current to the bridge. (The auxiliary oscillator, of course, is not necessary if the rectified tone can be conveniently fed to the bridge). A balance was obtained with $R_a = 3616$ ohms and $R_b = 1801$ ohms.

It was first desired to check a 1000-cycle tuning fork. R_a and R_b were therefore reduced to 44 percent of their original values, making $R_a = 1591$ ohms and $R_b = 792.4$ ohms. The oscillator controls were then

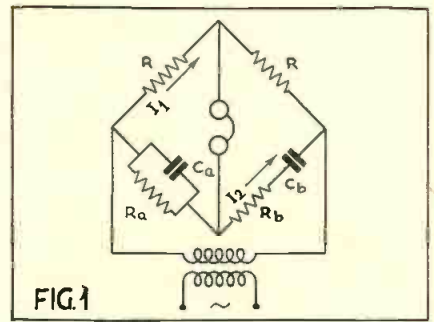

FIG. 1

adjusted for minimum response in detecting phones, under which condition the oscillator was known to be delivering 1000 cycles per second (errors in zero beat adjustment and in bridge circuit considered negligible). The oscillator output was then used to beat with one of the Riverbank Laboratories' "Duratone" precision 1000-cycle forks and found to be within 0.6 cycle, or a deviation between the two of only 0.06 percent.

To demonstrate the accuracy of the system, a further set of measurements was made, with results as indicated in the following table:

Frequency	R_a	R_b	Deviation from Fork in Cycles	Per cent. Deviation
440 (WWV)	3616.0	1801.0
250	6364	3170	0.1	0.04
500	3182.1	1584.9	0.4	0.08
1000	1591.0	792.4	0.6	0.06
1500	1060.7	528.3	0.6	0.04
2000	795.5	396.2	1.0	0.05
2500	636.4	317.0	1.5	0.06
3000	530.3	264.1	3.0	0.10
4000	397.8	198.1	2.4	0.06

In many cases a direct comparison with the tuning fork was impossible, as its harmonic output was too weak. In these cases a secondary oscillator was set at approximately 1000 cycles per second. Both oscillators were then connected to a cathode-ray oscillograph, the secondary one being varied in frequency until the correct stationary pattern was developed, whereupon beats were counted against the fork and corrected for the frequency multiple involved.

It is interesting to note the wide range of frequencies covered by the single pair of condensers. For the higher frequencies it would probably be preferable to diminish the values of C_a and C_b , thus permitting balance with a larger value of R_b , and minimizing the effect of any appreciable phase angle in C_b . Similarly at very low frequencies it would be preferable to increase C_a and C_b somewhat, not only to retain balancing resistances below 10,000 ohms but also to reduce the effect of the phase angle in C_a by a relatively low shunting resistance.

The important advantages of this bridge as a frequency measuring system are: (1) the avoidance of carefully calibrated reactance standards, standard resistance units only being required, and the actual values of C_a and C_b not entering into the results; and (2) the freedom from any harmonic

(Turn to Page 250)

¹See, for example, "Alternating Bridge Measurements," by B. Hague, Isaac Pitman & Sons, Ltd., 2nd. Ed.

²D. I. Cone, "Bridge Methods for Alternating Current Measurements," Trans. A. I. E. E., Vol. XXXIX, pp. 1743-1762; Henney, "Radio Engineering Handbook," pp. 179-180; Terman, "Measurements in Radio Engineering," pp. 136-138.

³J. G. Ferguson & B. W. Bartlett, "Measurement of Capacitance," Bell Sys. Tech. Jour., Vol. VII, pp. 420-437.

⁴Leo Behr and A. J. Williams, Jr., "The Campbell-Shackleton Shielded Ratio Box," Proc. I.R.E., June, 1932, pp. 969-988.

Practical Pointers for Servicemen on Servicing MOVIE SOUND

(The Problem of Noise Reduction)

THOSE details of exactly how to "sell" the theatre owner ordinary service are up to the serviceman for individual solution; upon his initiative and tact will rest the final result. This writer can do no more than give fair warning that easy going is not the order of the day when it comes to tackling a theatre owner on the subject of sound equipment service. We can, however, be more explicit on the details of noise elimination!

Noise, like trouble, resolves into two classes, electrical and mechanical. It is, of course, quite obvious that mechanical noise is not carried through the sound system. Rather the noise modulates audio frequencies passing through the system and so causes what amateur 'phone operators call "wobulation." This term, "wobulation," is used here to differentiate between electrically-transmitted noise from a mechanical source and the effect known as "flutter," which is caused by an uneven motion of the film past the aperture of the sound unit. It is obvious that any "flutter" must be eliminated before undertaking a noise reduction procedure.

Noise Sources

The mechanical noise sources are, of course, in the driving mechanism of the projector. Just how the noise gets into the system is something requiring study. For instance, in one theatre gear noise was not successfully eliminated until oil-soaked cables in the PEC amplifier had been replaced. The connection between the two is somewhat difficult to establish. The point is, any noise in the system having its source in the mechanism must get into the electrical circuits through some coupling or through the microphonic action of some variable connection.

Operators Can Help

Mechanical noises, like all others, are best attacked at the source, but even the best of machinery will run noisily at times. For this reason, the mechano-electrical couplings must be investigated and, where possible, eliminated or reduced. All mechanical noises cannot be taken care of in this fashion. The equipment must be in perfect running order and should be maintained that way. In this, it will be necessary to depend upon the operators, and getting their cooperation may be difficult.

Usually, union operators cannot or will not work with non-unionists. However, a tactful discussion with the operators will generally lead to some arrangement whereby the non-union service man will be enabled to side-step union rules and regulations. Non-union

By W. W. Waltz

(Part Three)

AS was pointed out in the previous articles, routine inspection may be difficult, if not impossible, to sell at the start. However, the old aphorism about "eternal vigilance" is peculiarly true of sound equipment. The occasion will automatically arise to talk routine service after it has been demonstrated that "tuning up" actually accomplishes something.

operators are less difficult of approach, but these men also have certain regulations to enforce and are, in general, quite alive to the danger in allowing violations. Invariably, the first and most prominent of these regulations is that prohibiting any but licensed operators in the projection room while the show is in progress. For this reason, it will usually be necessary to plan all work for before or after the day's shows.

The procedure for noise reduction will require, first of all, that a reference noise level be established to which all future measurements can be referred. Some form of level indicator must be provided for these measurements. Several models are available but for all practical purposes any ordinary output meter suitable for radio aligning will be satisfactory.

The Noise Level

To establish the reference level connect the level indicator across the output of the system.

Turn on the amplifiers, the exciting lamp and PEC amplifier, if any, of one projector. Increase the gain control of the system to its maximum position. Start the driving motor of the projector on which the exciting lamp is lighted and make certain that this projector is

connected to the system. Then read the level indicator. This reading, taken with the amplifiers "wide open," represents the maximum noise level that can be expected from the system. In actual operation, this level will be considerably lower because rarely, if ever, is the system run at full volume. As a check, repeat the noise-level measurement on the second machine. The two readings should agree within 2 or 3 db. In the event of a greater discrepancy choose the machine with the lowest level as the standard. Work should then be concentrated upon the other machine to try to reduce its noise to that of the "standard."

Reducing Noise

After the noise levels of the two projectors have been equalized as closely as possible, try for further noise reduction by going over the drive mechanisms; motors, gear trains, etc. Keep in mind that a reduction of 2 or 3db. on one machine will call for the same reduction on the other. If no substantial reductions in machine noise are being obtained, and if, with the volume level at normal or slightly higher, there is no objectionable noise discernable at the mouth of the stage horn; and if a sustained musical note comes through with no great amount of "wobulation," then it may be assumed that the system is quiet, in so far as the mechanical parts are concerned. A portable phonograph and pickup with a test record may be employed to provide the sustained note.

Exact instructions regarding volume, or level, of sound can not be given. What to one man is perfect may be unacceptable to another. Hence the need for measuring the various levels. When one can "see" a reduction in the noise level there is not much chance for argument.

The noises associated with the electrical circuits will be found similar to those met with in a noisy radio set—excluding static, of course. The methods of elimination are probably quite familiar to the radio service man. However, there are some points worth discussion because of the rather unusual ways of meeting them that have been adopted by theatre sound technicians. To simplify the discussion a general plan of attack will be outlined, after which the more unusual features will be considered in greater detail.

Power Supply

Clean all storage batteries, neutralizing with dilute ammonia any acid that may have been spilled. Coat all intercell connectors and *(Turn to page 236)*

A Service Opportunity

THE need for a systematic program of noise reduction becomes evident even to the most casual theatre-goer. To the serviceman looking for an opportunity further to establish himself in the theatre sound field, this need should mean an opportunity to sell a definite service, which may result in building up of a regular inspection service.



THE TESTS UNDER WAY AT FAIRFIELD
A corner of the Fairfield Beach, Conn., "Shack," one of the Listening Posts where tests of the "Philharmonic" were conducted by the authors.

Air Test Report on the "Philharmonic" 30-TUBE Receiver

(Latest Scott Custom-Built Set)

By Laurence M. Cockaday
and S. Gordon Taylor

(Part Three)

DURING a six-week "on the air" test of this new Scott receiver its performance was critically checked from every angle—sensitivity, selectivity, tone quality, flexibility of control, calibration, automatic volume control action, etc. In some of these important features it far exceeded the most demanding requirements, and in all of them it performed with a degree of excellence which should satisfy the most critical listener-in, whether he be a lover of fine music, a DX fan, a short-wave enthusiast or a combination of all three.

IT seems to be a case of "love at first sight" to everyone who hears this receiver in operation. During the tests occasional visitors were invited to listen in. Among these were musicians, radio engineers, housewives and non-technical businessmen. Regardless of

their vocations or avocations, their reactions were in every instance highly and even enthusiastically favorable. The receiver tested was one which was not in any way hand-picked or specially adjusted; nor was it given any special advantages insofar as the installation was concerned other than to use the special Scott antenna which is available to all Scott owners.

The naturalness of reproduction is possibly the most immediately impressive feature of the "Philharmonic." Not only do the individual instruments in an orchestra or band sound natural, but the orchestra as a whole really *sounds like an orchestra*—with, due to the volume expander, the wide variations in volume evident when one listens directly in the concert hall or theatre, but which

are conspicuous for their absence in the usual radio reproduction.

The provision for regulating the degree of automatic volume expansion by means of one of the front-panel controls was found helpful because full expansion was at times too great for comfort in a small room; that is, if the volume control were adjusted so that the softest passages of a symphony were barely audible, the loudest passages, while still entirely free from distortion, were overwhelmingly loud. By adjusting for an intermediate degree of expansion the reproduction was readily adapted to the requirements or limitations of any room.

The treble and bass response were likewise readily regulated to suit the program and surroundings. If one doesn't relish the continuous bass "tom-tom" effect of swing music, for instance, he need only retard the bass control knob to partially suppress the offending instrument. On the (Turn to page 246)

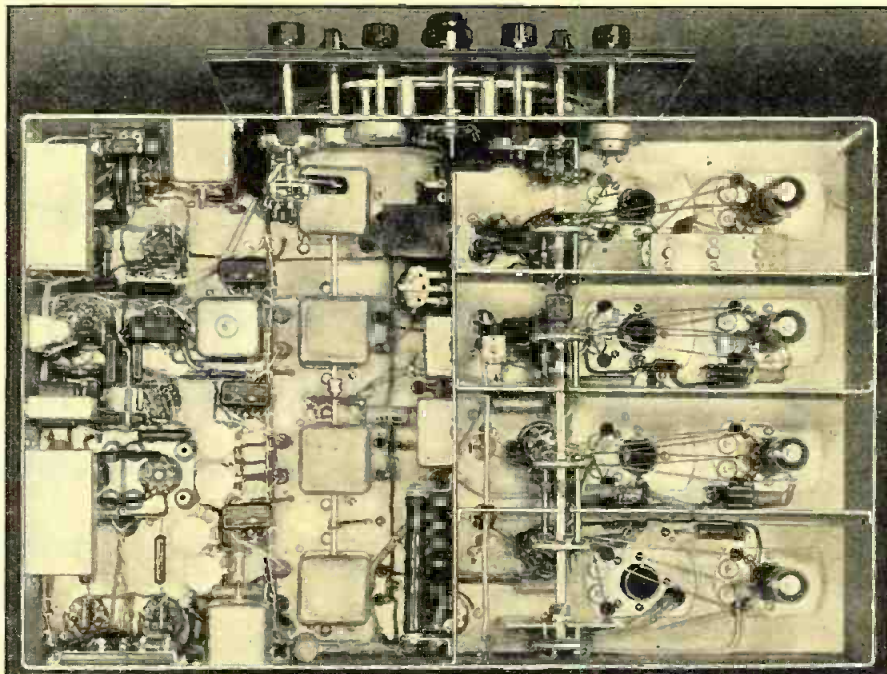
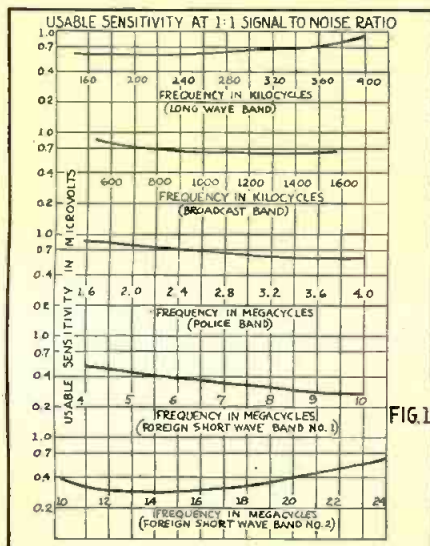

BROADCAST STATION LIST

(Africa, Asia, Oceania)

AFRICA											
ALGERIA											
Call	Location	Kc.	Kw.	Call	Location	Kc.	Kw.	Call	Location	Kc.	Kw.
.....	Algiers	825	15.0	Mayebashi	1000	0.5	Mayebashi	1000	0.5
EGYPT											
.....	Cairo (Abu Zabal)	620	20.0	Fukui	1020	0.3	Fusan, Korea	1030	0.15
.....	Assiut	731	0.25	Nagano	1040	0.5	Kagoshima	1050	0.5
.....	Alexandria (Ras-el-Tin)	1122	0.5	Toyama	1060	0.5	Kyoto	1070	0.3
.....	Cairo (Abu Zabal)	1348	0.5	Yamagata	1080	0.5	Heigo, Korea	1090	0.5
.....	Alexandria (Ras-el-Tin)	1429	0.5								
KENYA								MALAYA			
VQ7LO	Nairobi	810	0.75					ZHL	Singapore	1332	2.0
MOROCCO (FRENCH)								MANCHUKUO			
.....	Radio-Maroc I	601	6.0	Hsinking	560	10.0	Hsinking	560	10.0
.....	Radio Maroc II	868	6.0	Harbin	675	3.0	Dairen	760	0.5
REUNION ISLAND								Mukden	890	1.0
.....	St. Denis	617	0.16								
SO. RHODESIA								PALESTINE			
ZEB	Bulawayo	618.5	0.57	Jerusalem	668	20.0				
ZEC	Salisbury	681.8	0.6								
TUNISIA								SIAM			
TUA	Tunis	583	0.3	Sala Daeng (Bangkok)	750	10.0	Phyathai (Bangkok)	857	2.5
UNION OF SOUTH AFRICA								TURKEY (ASIATIC)			
ZTU	Grahamstown	560	10.0	Ankara	153.9	7.0				
ZTC	Capetown	600	10.0								
ZTJ	Johannesburg	645	15.0					U. S. S. R. (SIBERIA)			
ZTD	Durban	740	1.0	RV14	Irkutsk	187.5	20.0				
ZTE	Bloemfontein	809	0.75	RV76	Novosibirsk	217.5	100.0				
ZTP	Pretoria	952	0.05	RV11	Tashkent	256	25.0				
ZTX	Pietermaritzburg	697.7	10.0	RV60	Alma-Ata	310	10.0				
AFGHANISTAN				RV66	Krasnoyarsk	333	1.0				
.....	Kabul	20.0	RV19	Ashkabad	333	1.0				
(under construction)				RV63	Verkhneudinsk	350	10.0				
				RV47	Stalinabad	421	2.0				
				RV83	Oirat-Tura	450	1.0				
				RV44	Omsk	472	1.0				
				RV28	Cheliabinsk	577	10.0				
				Vladivostok	635	0.3				
				RV46	Karaganda	662				
				686	1.0				
				OCEANIA							
				AUSTRALIA							
XLHB	Shanghai, Kiang-su	560	0.045	Call	Location	Kc.	Kw.	Call	Location	Kc.	Kw.
XHJA	Hankow, Hoopie	570	2CR	Cummock, N. S. W.	550	10.0	Cummock, N. S. W.	550	10.0
XQHA	Shanghai, Kiang-su	580	0.25	6WA	Minding, W. A.	560	10.0	Minding, W. A.	560	10.0
XPKB	Tengchow, Shantung	590	0.1	3WV	Horsham, Vic.	580	10.0	Horsham, Vic.	580	10.0
XMHA	Shanghai, Kiang-su	600	0.6	4QN	Clevedon, Qnsld.	600	7.0	Clevedon, Qnsld.	600	7.0
XGSS	Tsunshi, Che-kiang	610	0.015	2FC	Sydney, N. S. W.	610	3.5	Sydney, N. S. W.	610	3.5
XHHK	Shanghai, Kiang-su	620	0.1	7ZL	Hobart, Tasmania	620	1.0	Hobart, Tasmania	620	1.0
ZEK	Hong Kong	620	0.25	3AR	Melbourne, Vic.	630	4.5	Melbourne, Vic.	630	4.5
XGOA	Nanking, Kiang-su	660	75.0	5CK	Crystal Brook, S. Austr.	640	7.5	Crystal Brook, S. Austr.	640	7.5
XGOY	Yunnan-fu, Yunnan	697	0.25	2DU	Dubbo, N. S. W.	660	0.1	Dubbo, N. S. W.	660	0.1
XMHJC	Shanghai, Kiang-su	700	0.5	7BU	Burnie, Tasmania	660	0.1	Burnie, Tasmania	660	0.1
XGMS	Chungking, Honan	711	0.0	2CO	Corowa, N. S. W.	670	7.5	Corowa, N. S. W.	670	7.5
XGML	Kashing, Kiang-su	714	0.0075	6WF	Perth, W. Austr.	690	3.5	Perth, W. Austr.	690	3.5
XLHC	Shanghai, Kiang-su	720	0.05	2NR	Lawrence, N. S. W.	700	7.0	Lawrence, N. S. W.	700	7.0
XLHD	Shanghai, Kiang-su	720	0.05	7NT	Kelso, Tasmania	710	7.0	Kelso, Tasmania	710	7.0
XHGS	Wuchow, Kwangsi	730	0.05	6GF	Kalgoorlie, W. Austr.	720	2.0	Kalgoorlie, W. Austr.	720	2.0
XHHB	Shanghai, Kiang-su	740	0.1	5CL	Adelaide, S. Austr.	730	2.0	Adelaide, S. Austr.	730	2.0
XGOK	Canton, Kwantung	750	1.0	2BL	Sydney, N. S. W.	740	3.0	Sydney, N. S. W.	740	3.0
XQKB	Tientsin, Pechili	750	0.15	3LO	Melbourne, Vic.	770	3.5	Melbourne, Vic.	770	3.5
XLHI	Shanghai, Kiang-su	760	0.0075	4QG	Brisbane, Qnsld.	800	2.5	Brisbane, Qnsld.	800	2.5
XLHJ	Shanghai, Kiang-su	760	0.1	3GI	Longford, Vic.	830	7.0	Longford, Vic.	830	7.0
XLHA	Shanghai, Kiang-su	780	0.05	5RM	Renmark, S. Austr.	850	1.0	Renmark, S. Austr.	850	1.0
XLII	Wusih, Kiang-su	790	0.075	7HO	Hobart, Tasmania	860	0.1	Hobart, Tasmania	860	0.1
XLHK	Shanghai, Kiang-su	800	0.0075	4AY	Ayr, Qnsld.	860	0.5	Ayr, Qnsld.	860	0.5
XLHL	Shanghai, Kiang-su	800	0.1	2GB	Sydney, N. S. W.	870	1.0	Sydney, N. S. W.	870	1.0
XQHC	Tientsin, Pechili	810	0.2	6PR	Perth, W. Austr.	880	0.5	Perth, W. Austr.	880	0.5
XLII	Wuhu, Ngan-li-wei	830	0.03	7QT	Queenstown, Tasmania	900	0.1	Queenstown, Tasmania	900	0.1
XGFM	Tsinan, Shantung	833	0.0075	2LM	Lismore, N. S. W.	900	0.5	Lismore, N. S. W.	900	0.5
XHHA	Changsha, Kiang-su	840	0.015	4RK	Rockhampton, Qnsld.	910	2.0	Rockhampton, Qnsld.	910	2.0
ZBW	Victoria, Hong Kong	845	2.0	3UZ	Melbourne, Vic.	930	0.6	Melbourne, Vic.	930	0.6
XQHB	Shanghai, Kiang-su	850	0.1	2UE	Sydney, N. S. W.	950	1.0	Sydney, N. S. W.	950	1.0
XLIO	Hangchow, Che-kiang	850	0.05	5DN	Adelaide, S. Austr.	960	0.5	Adelaide, S. Austr.	960	0.5
XHHD	Shanghai, Kiang-su	860	0.05	3BO	Bendigo, Vic.	970	0.2	Bendigo, Vic.	970	0.2
XLIL	Sueow, Kiang-su	870	0.075	6AM	Northam, W. Austr.	980	2.0	Northam, W. Austr.	980	2.0
XHHV	Shanghai, Kiang-su	880	0.1	2GZ	Orange, N. S. W.	990	2.0	Orange, N. S. W.	990	2.0
XGKA	Kashing, Che-kiang	895	0.015	4GR	Toowoomba, Qnsld.	1000	0.5	Toowoomba, Qnsld.	1000	0.5
XGOH	Changsha, Honan	896	0.15	3UL	Warragul, Vic.	1000	0.2	Warragul, Vic.	1000	0.2
XGOI	Shanghai, Kiang-su	900	0.5	3HA	Hamilton, Vic.	1010	0.75	Hamilton, Vic.	1010	0.75
XLIM	Haining, Che-kiang	910	0.05	2KY	Sydney, N. S. W.	1020	1.0	Sydney, N. S. W.	1020	1.0
ZGON	Nanking, Kiang-su	930	0.2	3DB	Melbourne, Vic.	1030	0.6	Melbourne, Vic.	1030	0.6
XHIE	Shanghai, Kiang-su	940	1.0	5PI	Crystal Brook, S. Austr.	1040	2.0	Crystal Brook, S. Austr.	1040	2.0
XGOF	Tsinan, Shantung	943	0.5	2CA	Canberra, N. S. W.	1050	0.5	Canberra, N. S. W.	1050	0.5
XGOP	Peiping, Pechili	950	0.3	2BH	Broken Hill, N. S. W.	1060	0.1	Broken Hill, N. S. W.	1060	0.1
XHHF	Shanghai, Kiang-su	960	0.1	4MB	Maryborough, Qnsld.	1060	0.1	Maryborough, Qnsld.	1060	0.1
XHHB	Wusih, Kiang-su	970	0.075	6WB	Katanning, W. Austr.	1070	2.0	Katanning, W. Austr.	1070	2.0
XMHB	Shanghai, Kiang-su	980	0.5	7HT	Hobart, Tasmania	1080	0.3	Hobart, Tasmania	1080	0.3
XGCK	Chuching, Che-kiang	990	0.0075	2AD	Armidale, N. S. W.	1080	0.1	Armidale, N. S. W.	1080	0.1
XGOD	Hangchow, Che-kiang	990	2.0	4MK	Mackay, Qnsld.	1080	0.1	Mackay, Qnsld.	1080	0.1
XGOT	Taiyuan, Shien-si	1000	0.05	3LK	Lubeck, Vic.	1090	2.0	Lubeck, Vic.	1090	2.0
				4LG	Longreach, Qnsld.	1100	0.3				

(Turn to page 231)



NEW AMERICAN TRANSMITTER
The 20,000-watt transmitter installed at station WIXAL, Boston, Mass., operating on the short-wave bands with excellent educational programs.

THE Fifty-fifth installment of the DX Corner for Short-Wave contains the World Short-Wave Time-Table for 24-hour use all over the world and Official Observers' reports of stations heard this month. Consult these two items regularly and make your allwave set pay big dividends!

Credit Where It Is Due

Excellent reports were sent in this month by Observers Alfred, Gossett, Hodgkyns, Diez and Doyle. Vacations are still believed to be the cause of such a small class of "star" reports, but those who made the grade receive our commendations and thanks.

News Notes

Observer Elmer Duncan of Louisville, Ky., will correspond with any SWL (either sex) and will answer all letters received.

Listeners who desire verifications from stations HRN, H19B, XEBM, HJ3ABX

OBSERVER FOR CALIFORNIA

Warner Howard at his receiving station in Los Angeles sends greetings to Radio News and its readers. Notice the copies of the magazine within easy reach.



The DX

for

SHORT

Conducted by

can send their report with a dime and 3c postage to Box 772, Santa Barbara, Calif. Verification cards will be mailed direct from the stations. International Reply Coupons are not honored by the postal authorities in these countries and the Quixote Radio Club is cooperating by making this service available to American Short-Wave Listeners. The Club guarantees verifications from each of these stations.

Attention! So. American Stations

South American stations are received excellently in the United States but our Observers are unable to log most of these stations because announcements are not being made often enough or in English! Please announce in English and you will have many more American Listeners (Radio News Short-Wave Observers).

Reports of Listening Post Observers and Other Short-Wave Readers of the DX Corner

LISTED in the following columns is this month's consolidated reports of short-wave stations heard by our wide-world listening posts. Each item is credited with the Observer's surname. This allows our readers to note who obtained the information. If any of our

readers can supply Actual Time Schedules, Correct Wavelengths, Correct Frequencies and any other Important Information (in paragraphs as recommended), the DX Editor, as well as our readers, will be grateful for the information. On the other hand, readers seeing these reports can try their skill in pulling in the situations logged and in trying to get complete information on these transmissions. The report for this month, containing the best information available to date, follows:

Europe

TPA2, Paris, France, 15,240 kc., daily 5-11 a.m. (Gossett). Slogan: "Radio Colonial."

TPA3, Pontoise, France, 11,885 kc., 4:30-5 p.m. (Dressler, Wicks, Fuller).

TPA4, Pontoise, France, 11,720 kc., 1:30 p.m. (Eder), 10:30 p.m. (Duncan, Bauer, Diez).

EQP1, Madrid, Spain, 6995 kc., 4:20 p.m. (Sporn).

EAQ, Madrid, Spain, 9860 kc., daily

ONE TO BE PROUD OF!

This rare verification card of HS8PJ, at Bangkok, was received by R. J. Abbott of England for his report on their transmission. This is one for American listeners to try for.

1836/37

Situation 100 32 00 E 13 44 30	Owner Post & Telegraph Dept
Frequency 19.22 mc (1597 m)	Mode of Xmitr. home-made
Oscillator crystal controlled	
Power 5 watt output	SCHEDULE OF TESTS
Antenna cat's paw	Date 11/10/37
Modulation grid driven	Time 1:52-1:52 pm
Tubes Telefunken 2X 210, 6X 201A	Type of programme Bismesse and European music. Local radio news bulletin. Announcements in Bismesse, English & French
RCA 233 A. Marconi CATZ	
Mike Telefunken 210, carbon	
Pick-up RCA	
A.F. ampl. vact	



HS 8PJ

THE EXPERIMENTAL RADIO BROADCASTING STATION AT SALADENG, BANGKOK, SIAM.

With thanks we beg to verify correct your report of reception dated Dec. 11, 1937. Further reports will always be appreciated.

Tha Aram

Corner

the

WAVES

L. M. Cockaday



AN INTERESTING "VERI" FROM MARACAIBO
 Jerome Roberts, of Racine, Wisconsin, received this verification card from YVIRL. The reverse side tells an interesting story of this capital city.

5-7:30 p.m., Sunday 3-4 p.m. (Alfred, Gossett, Chandler), 2-5:10 p.m. (Sporn, Ralat, Nigh, Hodgkyns). Address: P. O. Box 951.
EAQ2 (EAR), Madrid, Spain, 9500 kc., Monday, Friday, 7:30-9:30 p.m., (Alfred), daily 6-9:30 p.m., (Gossett, Chagaris), 9480 kc., (Chandler, Kemp,



A NEW YORK CITY POST
 The DX Corner of John Blechu, of Long Island City, who uses an RCA-136 receiver and a doublet antenna.

Schrock, Fallon, Nigh, Fleming, Conceyro, Hodgkyns, Kemp, Diez).
Radio Requete, Madrid, Spain, 14,007 kc., 7 p.m., (Ralat), contacts 20 meter amateurs. (Hartzell), 14,070 kc., (Shamleffer).
I2RO4, Rome, Italy, 11,810 kc., 4:30 p.m., (Welper), Sunday, 4-5:15 p.m., (Dressler, Shamleffer), daily 6 a.m.-10:20 a.m. (from veri.), (Randle), daily 6-7:45 p.m., Sunday 11:30 a.m.-5:30 p.m., (Cindel), Address: 5 Via Montello, Rome.
CSW, Lisbon, Portugal, 9940 kc., signs daily 8 p.m., (Alfred), 11,840 kc., 11:30 a.m.-2 p.m., (Gossett), daily 7:30-9:30 p.m., (9940 kc.), daily 3-6:30 p.m., (11,040 kc.), (Dressler, Ralat, Shamleffer, Eder, Kemp, Doyle), daily 12 a.m.-9 p.m., (from veri.), (Stabler).

CT1AA, Lisbon, Portugal, 9650 kc., Tuesday, Thursday, Saturday, 3-6 p.m., interval signal is three cuckoo calls, (Sokolovsky), 9665 kc., (Gresham, Hartman, Shamleffer, Westman, Fleming), Slogan: "Radio Colonial".
DJL, Zeesen, Germany, 15,110 kc., 4:50-10:45 p.m., (Alfred), 11:45-4 p.m., (Gossett, Chandler, Hartman, Hodgkyns, Kemp), Sunday, 9 a.m.-1:15 p.m., (Shamleffer).
DJN, Zeesen, Germany, 9540 kc., daily 4:50-10:45 p.m., (Alfred, Chandler, Dressler, Wicks, Wittig, Nigh, Hendry, Hodgkyns, Eder, Kemp, Diez, Doyle).
DJQ, Zeesen, Germany, 15,280 kc., daily 4:50-10:45 p.m., (Alfred, Chandler, Dressler, Wicks, Wallenschlager, Hodgkyns, Eder, Kemp, Diez, Gullberg).
DIP, Zeesen, Germany, 14,410 kc., 4:50-10:45 p.m., (Alfred, Poll), 3 p.m., (Sporn, Doyle).
DZB, Zeesen, Germany, 10,420 kc., 3:20-4:00 p.m., (Sporn).
DJA, Zeesen, Germany, 9560 kc., 4:50-10:45 p.m., (Alfred, Chandler, Dressler, Wittig, Hendry, Hodgkyns, Eder, Diez, Doyle).
DZB, Zeesen, Germany, 10,420 kc., 4:50-10:45 p.m., (Alfred, Hartman, Dressler, Wollenschlager, Hodgkyns, Eder, Kemp, Diez, Doyle, Black).
DJC, Zeesen, Germany, 6020 kc., 11 a.m.-2:20 p.m., (Doyle).
DJD, Zeesen, Germany, 11,770 kc., daily 4:50-10:45 p.m., (Alfred, Hartman, Dressler, Duncan, Wollenschlager, Eder, Diez, Doyle, Black).
RW96, Moscow, U.S.S.R., 15,180 kc., Sunday 2-3 p.m., (Gossett).
RIO, Baku, U.S.S.R., 9595 kc., 7:15 a.m., (Sporn).
RAN, Moscow, U.S.S.R., 9595 kc., daily 7-9:15 p.m., (Alfred, Shamleffer, Sokolovsky, Kemp, Dressler, Ralat, Jordan, Mott, Smith, Hendry, Hodgkyns, Eder, Kemp, Anca).
RKI, Moscow, U.S.S.R., 15,040 kc., daily 7-9:15 p.m., (Alfred, Messer, Eder, Gresham, Chagaris, Shamleffer, Kemp, Dressler, Atherton), 15,145 kc., 11-11:30 a.m., (Welper, Dressler, Jordan, Hodgkyns, Bauer, Hamilton, Anca), Slogan: "Radio Moscow".
RNE, Moscow, U.S.S.R., 12,000 kc., irregular, 10:15-11:30 p.m., (Alfred, Sokolovsky), Sunday, Wednesday, 6-7 a.m., Sunday 10-11 p.m., Sunday, Monday, Wednesday, Friday, 4-5 p.m., daily 3-6 p.m., Monday, Thursday, 8-9

p.m., Gossett, Ralat, Schrock, Shamleffer, Beard, De Laet, Hodgkyns), 12,065 kc., (Kemp).
OLR4A, Prague, Czechoslovakia, 11,840 kc., Wednesday, 2-4:30 p.m., Tuesday, Thursday, 8-11 p.m., (Alfred, Shamleffer, Wicks), Monday, Thursday, 7-9:10 p.m., (Dressler, Noyes, Jordan, Mott, Hodgkyns, Eder, Kemp, Gullberg, Messer, Wittig, Chandler, Stillman).
OLR5A, Prague, Czechoslovakia, 5,230 kc., (Gossett), 9:30 p.m., (Eder), daily 2-2:15 p.m., Monday, Thursday, 8-10:10 p.m., daily 7:55-9:50 p.m., (Shamleffer, Welper, Wicks, Dressler, Mott, Hodgkyns, Eder, Diez, Gullberg, Hamilton, Anca).
OLR4C, Prague, Czechoslovakia, 11,875 kc., Monday, Thursdays, 7:55-11 p.m., (Nigh, Hodgkyns).
HBO, Geneva, Switzerland, 11,402 kc., Saturday 7-8:45 p.m., (Alfred, Shamleffer, Markuson), Saturday, 5:30-6:15 p.m., 7-8:30 p.m., (Doyle, Eder), same address as HBJ.
HBJ, Geneva, Switzerland, 14,535 kc., Saturday, 7-8:45 p.m., (Alfred, Markuson, Gross), 12:30-12:45 p.m., (Shamleffer, Eder, Kemp), Address: Radio Nations, 12, Quai de la Poste, Geneva.
HBP, Geneva, Switzerland, 14,535 kc., Saturday, 7-8:30 p.m., (Poll, Sargent), 7797 kc., (Eder, Kemp), same address as HBJ.
HBF, Geneva, Switzerland, 18,450 kc., Saturday, 7-8:30 p.m., (Eder), same address as HBJ.
GSD, Daventry, England, 11,750 kc., 4:30-5:45 p.m., (Alfred), daily 9-11:15 p.m., (Dressler), 7:30 p.m., (Duncan), (Turn to page 226)

SWEDEN ON THE MAP!
 Meet Observer Olaf Liljegren, of Mariestad, Sweden, who enjoys his short-wave radio and his pipe.



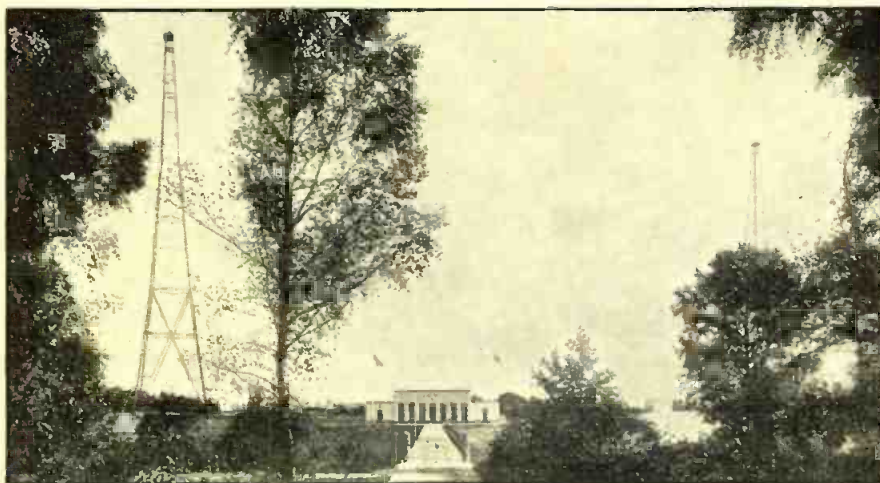

The DX Corner (Short Waves)

(Continued from page 223)

Wollenschlager, Harley, Duncan, Hodgkyns, Eder, Diez, Kemp, Black, Law).

GSF, Daventry, England, 15,140 kc., 4:30-5:45 p.m., (Alfred, Noyes, Hodgkyns, Kemp).

GSG, Daventry, England, 17,790 kc., 4:30-5:45 p.m., (Alfred), daily, 9-11:15 p.m., (Dressler, Welper, Shamleffer, Wollenschlager, Noyes), 1 a.m., (Harley, Hodgkyns, Kemp, Diez, Law).

GSB, Daventry, England, 9510 kc., 9-11 p.m., (Alfred, Dressler), 4 p.m. and on. (Noyes, Harley, Hodgkyns, Eder, Kemp, Diez, Doyle, Law).

GSC, Daventry, England, 9580 kc., 9-11 p.m., Alfred, Chandler, Wollenschlager, Hendry, Hodgkyns, Kemp).

GSI, Daventry, England, 15,200 kc., (Chandler), daily 9-11:15 p.m., (Dressler, Hodgkyns, Eder, Kemp), 15,260 kc., (Doyle).

GSO, Daventry, England, 15,180 kc., (Chandler), begins 4 p.m., (Noyes), 1 a.m., (Harley, Hodgkyns, Eder, Diez, Kemp).

GSJ, London, England, 21,530 kc., 9:15-12 p.m., (Schrock, Dressler, Hodgkyns, Doyle), 8 p.m., (Duncan, Law).

GSK, Daventry, England, 26,100 kc., 6-8:50 a.m., (Doyle).

ORK, Brussels, Belgium, 10,330 kc., irregular 2-3 p.m., (Alfred, Sokolovsky), daily 12:30-2 p.m., (Doyle).

TFJ, Reykjavik, Iceland, 12,235 kc., Sunday, 1:40-2:30 p.m., (Alfred, Gossett, Fleming, Hodgkyns, Kemp, Nigh).

HAT4, Budapest, Hungary, 9125 kc., Sunday 7-8 p.m., (Alfred), Sunday, 6-8 p.m., (Schrock, Shamleffer, Smith), Monday, Thursday, Saturday, 7-8 p.m., (Hodgkyns, Eder, Cindel), Address: Radio Labor Iyali 22, Budapest.

PHI, Huizen, Holland, 17,765 kc., daily 8:30-9:30 p.m., Sunday, 7-12 a.m., (Gossett, Birnie, Kemp), 17,870 kc., (Diez).

PCJ, Huizen, Holland, 15,220 kc., Tuesday, 4:30-6 a.m., Wednesday, 7-11 a.m., (Gossett, Chandler), 9590 kc., (Eder, Kemp, Shamleffer, Mott, Fleming), Slogan: "The Happy Station".

HAS3, Budapest, Hungary, 15,375 kc., Sunday 9-10 a.m., (Gossett, Hodgkyns, Gullberg), 9125 kc., Sunday, Wednesday, 7-8 p.m., (Cindel), Address: Radio Labor, Gyali Ut. 22.

LZA, Sofia, Bulgaria, 14,960 kc., daily 5-6:30 a.m., (Gossett), 14,920 kc.,

A NEW SWEDISH STATION
This is SBG, Motala, Sweden, now operating on 11705 kc. and 6065 kc., daily, with 10 kw. Another one for American listeners to try for.

(Sporn), 14,970 kc., (Eder), Slogan: "Radio Garata", Address: Radio Sofia, 19 Moskovska Street, Sofia.

SPW, Warsaw, Poland, 13,630 kc., Wednesday, Friday, 12:30-1:30 p.m., (Gossett, Eder, Gresham, Shamleffer, Beard, Jordan, Kemp, Bauer).

SBG, Motala, Sweden, 11,710 kc., 9 a.m.-1 p.m., (Gossett), irregular around 5 p.m., (Hartzell, Sargent, Bauer), daily 11 a.m.-4 p.m., (Gullberg), Slogan: "Radio Samola".

YTC, Belgrade, Yugoslavia, 6100 kc., 2-2:30 a.m., (Sporn), 7:45-8:14 p.m., (Messer).

LKJ1, Oslo, Norway, 9530 kc., 12-7 p.m., (Sporn), Sunday, Wednesday, 11-12 p.m., 4-8 a.m., (Doyle).

YUA, Belgrade, Yugoslavia, 6100 kc., daily 12:45 a.m.-5 p.m., (Gullberg).

OER2, Vienna, Austria, 11,800 kc., Saturday 11 a.m.-6 p.m., Monday, Friday, 11 a.m.-5 p.m., (Doyle).

Africa

FIQA, Tananarive, Madagascar,

NEAT BUT NOT GAUDY

Short-wave listener Donald Robinson of Joliet, Illinois, uses a Hallicrafter Super-7 for short-wave DX'ing. He finds RADIO NEWS a veritable short-wave "Bible"



11,810 kc., 9523 kc., 6005 kc., reports are requested, daily weekdays, 1:30-2:30 p.m., (Hodgkyns), Address: Direction des P. T. T., Hotel des Postes, Place Colbert, Tananarive, Madagascar.

CR6AA, Lobito, Angola, Portuguese West Africa, 9666 kc., 7177 kc., Wednesday, Saturday, 2:45-4:30 p.m., (Sokolovsky, Birnie), 6550 kc., (Doyle).

CR7BH, Lourenco Marques, East Africa, 11-718 kc., weekdays, 4:30-6:30 a.m., (Hartzell).

"Poste Bizertion", Tunisia, North Africa, 6163 kc., tests 3 p.m., daily 10 a.m., (Hodgkyns), interval signal is one gong stroke. Address: Poste Bizertin Boile Postale 72, Bizerta, Tunisia.

Johannesburg, South Africa, 6091 kc., daily 11:45 p.m.-2:30 a.m., 3:15-7 a.m., 9-11:30 a.m., 2-3 p.m., (Hodgkyns).

EAJ43, Tenerife, Canary Islands, 10,370 kc., 6:15 p.m., (Rulat), 10:360 kc., daily 6-9:15 p.m., (Fallon, Shamleffer, Eder, Alfred, Dressler), irregular, (Diez).

EA9AH, Tetuan, Spanish Morocco, 14,004 kc., Saturday 6:30 p.m., (Shamleffer, Hartzell, Eder), 14,070 kc., daily 8-11 p.m., (Gossett, Smith, Kemp), 7080 kc., (Doyle).

OQ5AA, Tondo, Belgian Congo, 14,150 kc., 3 p.m., (Gossett).

SUV, Cairo, Egypt, 10,050 kc., 5:30-6:30 p.m., (Doyle).

SUZ, Cairo, Egypt, 13,820 kc., 5:30-6:30 p.m., (Doyle).

Oceania

VK3LR, Melbourne, Australia, 9580 kc., heard 6:40 a.m., (Eder) Monday and Friday, 3:30-8:30 a.m.—Saturday 5-8:30 a.m.—Sunday 3-7:30 a.m., (Gossett, Alfred, Fuller, Williams) signs with "God Save the King", (Fleming, Kemp).

VPD2, Suva, Fiji Islands, 9590 kc., heard 6:50 a.m., (Eder) 5:30-7 a.m., 9540 kc., (Gossett).

KKP, Kahuku, Hawaii, 16100 kc., heard 3-9 a.m. and irregular. (Gossett) 16030 kc., (Jordan), Address: P. O. Box 200.

VK2ME, Sydney Australia, 9585 kc., Sunday 5-9 a.m., (Gossett, Sargent), (from veri.), (Williams, Kemp, Meyers), Slogan: "The Voice of Australia".

VK6ME, Perth, Australia, 9590 kc., daily 6-9 a.m., (Markuson, Gossett, Meyers).

VK3ME, Melbourne, Australia, 9500 kc., daily 4-7 a.m., (Schrock, Eder) 9510 kc., (Gossett, Alfred, Fuller, Kemp, Meyers).

W10XDA, "S. S. Morrisey", 12860 kc., (Skinner) 14250 kc., contacts amateurs, (Hartzell) 12880 kc., 6:45-7:15 p.m., (Kemp, Unger).

ZMBJ, "S. S. Awatea", 8840 kc., (Wellington, New Zealand, (Hodgkyns), Slogan: "The Voice and Ears of Tasmania."

Asia

PLP, Bandoeng, Java, 11,000 kc., daily 6-7:30 a.m., (Alfred) heard 5:30-10:30 a.m., (Nigh, Fleming, Black).

PMN, Bandoeng, Java, 10,260 kc., irregular, 6-7:30 a.m., (Alfred) heard Thursday 5:40 p.m., (Smith, Black).

PLV, Bandoeng, Java, 9415 kc., heard 6:15-6:30 p.m., with 7 gongs; announced in Dutch. (Shamleffer).

YDB, Bandoeng, Java, 9550 kc., (Birnie) heard 6:45 a.m., (Eder).

YBG, Medan Gumatia, Java, 16,430 kc., 7:30-8:30 a.m., (Doyle).

JVH, Nazaki, Japan, 14,600 kc., (Sokolovsky) 14,610 kc., heard 6-11 p.m., (Gossett).

JIB, Taiwan, Formosa, Japan, 10,535 kc., heard daily 6:30 a.m., (Alfred).

JVN, Nazaki, Japan, 10,660 kc., daily 6-7:30 a.m., (Alfred, Sokolovsky, Chandler, Hodgkyns, Doyle).

JZJ, Nazaki, Japan, 11,800 kc., daily 12-1 a.m., (Sokolovsky) daily 3-4 p.m., (Kashimoto) daily 8-9 a.m., (Eder, Poll, Hare, Markuson, Schrock, Madanski), daily 4:30-5:30 p.m., (Partner, Fleming, Black, Unger, Gullberg, Doyle).

JZI, Nazaki, Japan, 9555 kc., 7-8 a.m. and 9-10 a.m., (Doyle).

JZK, Nazaki, Japan, 15,160 kc., daily 3-4 p.m. and 8-9 a.m., (Kashimoto) daily 5:30-6:30 p.m., and 12:30-1:30 a.m., (Poll, Hare, Markuson, Welper, Schrock, Partner, Abbott, Beard, Wollenschlager, Sargent, Eder, Black, Gullberg, Doyle).

XOJ, Shanghai, China, 15800 kc., heard 10:45 p.m., (Alfred).

ZBW4, Hong Kong, China, 15,185 kc., heard 11 p.m.-1:15 a.m., (Gossett) Saturday 9:15 p.m. 1 a.m.; Sunday 3-9:30 a.m., (Doyle).

ZBW5, Hong Kong, China, 17,750 kc., heard 3-9 a.m., (Gossett).

ZBW3, Hong Kong, China, 9,525 kc., heard 4-10 a.m., (Gossett).

XGOX, Nanking, China, 6820 kc., heard 5:30-9:40 a.m., (Schrock) 6850 kc., (Doyle).

CQN, Macao, China, 10133 kc., (Schrock) Monday 7-8:30 a.m., (Fleming, Birnie).

(Turn to page 234)

EVERYTHING IN RADIO *at Lowest Prices*

FOR DEALERS · SERVICEMEN · SOUNDMEN · AMATEURS · EXPERIMENTERS

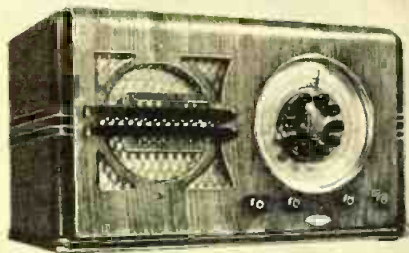

65 GREAT NEW KNIGHT RADIOS!

Automatic Tuning, powerful performance and rich tone are the features of the new KNIGHT Radios. Models for every taste and purse, from 5 to 16 tubes, for AC, AC-DC, 6 Volt, 32 Volt, Battery and Auto operation. Beautiful Console, Chairside, Phono-radio, Table and Chassis models—at unbeatably low prices. See all 65 models in your 1938 ALLIED Catalog!

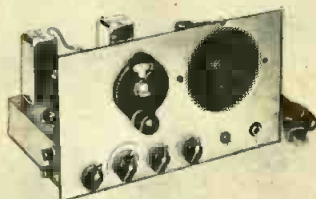

32 TESTED AND APPROVED KITS!

Radio Builders—here's an assortment of kits ranging from a 1 Tube set to a 14 Tube All Wave Superhet—kits for every purse and purpose! Write for Free Parts Lists—for any kit described in any radio publication.

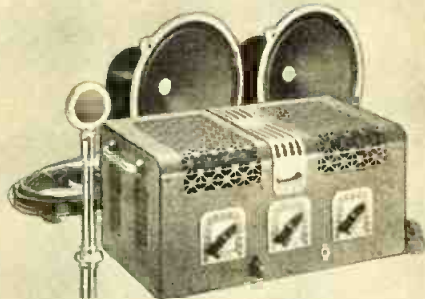

26 MODERN P. A. SYSTEMS!

KNIGHT "Integrated" Sound Systems from 8 to 60 watts—portable, permanent and mobile—for 110 Volt, 6 Volt and Universal operation. Also—new 2-Way, Selective and Superselective KNIGHT Intercom Systems.

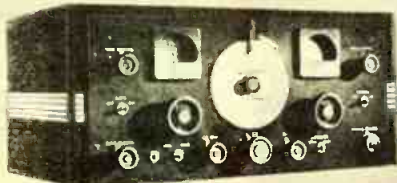

26 LATEST AMATEUR RECEIVERS!

See the most complete line of Amateur receivers in Radio—beginning on page 114 of your 1938 ALLIED Catalog! Radio's leading makes—National, Hallicrafters, RCA, Sargent, Hammarlund, etc. Also latest RCA, Utah, and All-Star Transmitters; books, parts, tools. Everything from a grid cap to a 1/2 KW X-mitter!

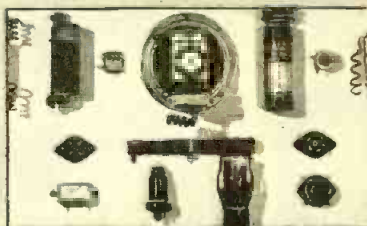

MORE THAN 12,000 RADIO PARTS!

Listing more than 12,000 exact duplicate and replacement parts, the 1938 ALLIED Catalog offers a tremendous assortment for repairing or building any radio circuit. This great book enables you to spot the part you want—conveniently, quickly, exactly!

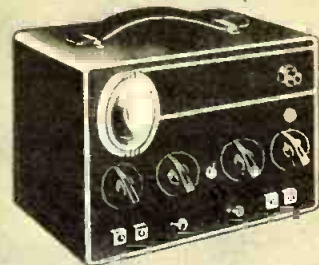

68 NEWEST TEST INSTRUMENTS!

Radio's most extensive line of test instruments—new 2" Cathode Ray Oscilloscope, Oscillographs, Analyzers, Tube-Checkers, Set-Testers, Signal Generators, Meters, etc. Also, new Build-Your-Own Kits and 20,000 ohms-per-volt equipment.

Allied's 1938 Catalog
BRINGS YOU THESE
AMAZING *New* DEVELOPMENTS

*New
Different
Complete*

164 PAGES PACKED WITH SETS · PARTS · KITS · AMATEUR GEAR · P. A. SYSTEMS · TEST EQUIPMENT

Free

SEND COUPON

WRITE FOR ALLIED'S NEW 1938 CATALOG—RADIO'S LEADING SUPPLY GUIDE!

Send for this great book today—164 big pages packed with Everything in Radio! Thousands of parts, dozens of radio sets, kits, Public Address Systems, Test Instruments, Amateur Receivers, books, tools, etc.—at prices that will save you money on every purchase. See the separate P.A., Amateur, Service and Radio Set sections—see the revised, extended parts sections—see 1938's latest radio developments—all in your 1938 ALLIED Catalog! It's new, complete, and different from any other radio book ever published—a book written by and for radio men. Every page has been planned to make your radio buying easier and more profitable. Write for your FREE copy now—it's radio's easy-to-read, easy-to-shop, easy-to-order-from catalog!

EVERYTHING IN RADIO — AT LOWEST PRICES!

ALLIED carries in regular stock all leading radio lines at lowest prices. We can obtain for you special or "hard-to-get" equipment on short notice—our central location under one great roof means faster service for you. Consolidate your purchases—fill all your radio needs from one single dependable source—ALLIED—Radio's Leading Supply House!

ALLIED RADIO CORPORATION
 833 WEST JACKSON BLVD., CHICAGO, ILL.

ALLIED RADIO Corp.
 Dept. 1-K8
 833 W. Jackson Blvd.,
 Chicago, Ill.

Send me your 1938 Catalog—Radio's Leading Supply Guide.

Name

Address

City State



Only RCA Victor gives you ELECTRIC TUNING

PUSH A BUTTON ...THERE'S YOUR STATION!



● RCA Victor Electric Tuning is the most important radio news in 7 years! Gets any one of your 8 favorite stations easily, swiftly—with the simple push of a button! Tunes them with uncanny precision. Shown here is Model 811K. Besides Electric Tuning it offers Armchair Control (slight extra cost), Straight-line Dial, Sonic-Arc Magic Voice, and a host of other features. Easy terms at your dealer's.



RCA Victor
RCA Manufacturing Co., Inc., Camden, N. J.
A service of the Radio Corporation of America

Hot off the press!
Ghirardi's POCKET TROUBLE SHOOTERS
SPEED UP YOUR SERVICE WORK with these amazing, wonder-working Gadgets. Just the flip of a card and you get the test and remedy for any trouble in any receiver. One Gadget for HOME, one for AUTO radios—each one spots over 400 troubles with lightning speed. The handiest, simplest, quickest service aid you ever saw. **FOR \$1.00** (foreign \$1.20) **RADIO & TECHNICAL PUBL. CO.** 45 Astor Place, New York

RADIO ENGINEERING TRI-STATE COLLEGE DEGREE IN 2 YEARS.

Complete Radio Engineering Course in 96 weeks. Bachelor of Science Degree. Radio (television, talking pictures and the vast electronic field) offers unusual opportunities for trained radio engineers. Courses also in Civil, Electrical, Mechanical, Chemical, Aeronautical Engineering, Business Administration and Accounting. Low tuition, low living costs. World famous for technical two-year courses. Those who lack high school may make up work. Students from all parts of the world. Enter September, January, March, June. Write for catalog. 16106 College Ave., Angola, Ind.

MANHEIM POCKET SLIDE RULE
Polished stainless steel back frame, flexible scale slide, glass hairline runner. A B C D scales. Length closed 8". No celluloid—no wood. Non-shrinking. Accuracy guaranteed. In leather case with instruction booklet.
ONLY \$1.00
Postage Paid
Sevan Co.
Dept. 18
7 E. 42 St.
New York City



Figure 9. Three views of the Dixie Radio Company—this month's success story.

THE SERVICE BENCH

(Continued from page 217)

shield base—but the 41 belongs there!
"Incidentally, the 950 is generally recommended as interchangeable with the type 33. However, this really is not the case as the filament drains are different. If a 33 is substituted for a 950, as for instance in a Montgomery Ward battery set, the "A" battery control rheostat has to be set higher—for lower resistance."—Edward Scribner, Schoharie, N. Y.

A Tip for the Dust Storm States

Edwin Lovick, Jr., of Falls City, Nebraska, sends through the following kink which should be of use to servicemen unfortunate enough to be located in the dust areas that are rapidly covering a large portion of the south-western United States. He reports that dust in trimmers has been responsible for noise and insensitivity. He advises sealing the i.f. trimmer holes—after careful realignment—with small pieces of gummed paper and tape, and tacking a piece of cloth over the rear of the cabinet. Mr. Lovick also runs into considerable trouble with the—

Montgomery Ward

1935 and 1936 battery sets, due to leaky 4 mfd. condensers.
Eugene C. Drobeck, 804 Garland Avenue, Los Angeles, California sends through the following—

Service Notes

"Peter Pan: Receiver dead and checked 4.5 volts across filter input. The trouble was caused by a short-circuited .01 mfd. condenser (600-volt by-pass) from the plate of the 42 tube to ground. In Peter Pan models employing two 24s, a 47 and an 80, when it is necessary to replace a noisy volume control, be sure that the new one is grounded at the center lug—that is the movable arm. If it is not grounded through the mounting, use a short lead.
"Golden Bear: No. 15585 and similar models. Distortion may be caused by the misuse of a 50,000-ohm resistor as volume control at the input to the second detector. The correct value is 500,000 ohms.
"Broadway: The by-pass condenser across the first r.f. cathode was found to be open intermittently. Installation of a

good .2 mfd. condenser cured the trouble.
"Radiola 60: To stop the speaker armature from striking the metal at the rear, draw up the cone around the edge and re-gue. Or better yet, install a good permanent-magnet dynamic.
"Packard Bell: Model 120 (1937). Distortion seems to be a common complaint with this receiver and the condition can be readily remedied by shunting the 250-ohm bias resistor of the 6F5 audio tube with an additional resistor of 400 ohms.
"Atwater Kent: Model 60. Have had two cases of voice-coil leads breaking at the point where they leave the cone glue, which is used to fasten the wire to the cone. In repairing this, either pull some of the glued wire away from the cone for a half-inch or so and resolder, or employ a piece of metal dial cable. In any case, be sure to pull the wire away from the cone at the point of soldering, or vibration will be very likely to cause crystalization and another break."
Mr. Drobeck mentions that he finds Johnson's "Glo-Coat" liquid wax satisfactory and time-saving in polishing cabinets. It is easy to apply and requires no rubbing to produce a high polish.

SERVICE SALES PROMOTION

Writes Mr. Walter J. Robertson, of Huntington Park, Calif., concerning the self-addressed business reply card shown in Figure 8: "These cards cost me approximately \$7.00 per thousand and \$1.50 per thousand for distribution. I have a couple of boys in the neighborhood distribute these cards from door-to-door on Saturdays. Although replies start dribbling in the following week, some of the cards distributed in a given territory are not received for as long as seven or eight months—thus indicating that many people will save these cards until trouble does occur. Replies are carefully marked on a large scale map of Huntington Park and surrounding towns. In this manner the coverage of the cards is clearly indicated; and it also shows where repeat canvass is desirable. To date I have received an average of one reply for thirty cards distributed. With rare exceptions, each reply means money in the cash drawer.
"Unquestionably, the details of the firm's

policy as given at the bottom of the card will cause many servicemen to throw up their hands in horror or disgust! However, the ever-increasing number of names appearing in my active card file is convincing proof of its practical merit. And each one of the four items of the policy means exactly what it says—even "Credit Cheerfully Given." All-in-all, it means that the customers are satisfied and that I make a fair profit. No business could ask for more!"

Service Success Story for the Month

The Dixie Radio Company, Columbia, S. C., three views of which are shown in Figure 9, presents an outstanding example of what can be done by aggressive action and an appreciation of local demand. The organization was started back in 1933, as a retail service business with a small capital. Sensing the need for a parts-distribution organization in the territory, combining wholesale service as a feature, activity was refocused in this direction. Quality parts were stocked, and National Union taken on as a tube line. Servicing was limited to the wholesale field, and from the beginning progress was rapid.

Today the organization employs six full-time servicemen, two parts salesmen who travel the territory in well-stocked trucks, a young lady behind the counter who is reputed to be one of the best parts sellers in the east, two bookkeepers, a man in charge of packing and shipping, and a porter. The personnel is directed by Mr. F. E. Beaudry, General Manager, in co-operation with Mr. J. A. Krell, the proprietor of the company.

The progress and success of the Dixie Radio Company is particularly worthy of note because of the fact that it was attained in the face of the general depression.

Raytheon Awards Grand Prize For Servicemen's Contest!

One of the high spots of the recent Radio Parts Show was the presentation of the grand prize of \$600.00 to George F. Chastain of Monett, Mo., winner of Raytheon Servicemen's Contest. Earl Dietrich,



Raytheon Sales Manager, took time out in a hectically busy four days to make the presentation at one of the technical meetings during the show. Mr. Chastain's entry was considered the best of thousands submitted and he was a surprised and delighted young man. Recently married, he attended the convention accompanied by his wife, and the young couple thoroughly enjoyed their first visit to Chicago under the pleasant circumstances. Since the modest young couple have been married only two months, they will probably have plenty of places to put their windfall.

\$1,000.00 IN PRIZES OPEN TO EVERYONE!



Enter THE \$1,000 CONTEST Now

LET THIS New Free 1938 WHOLESALE RADIO CATALOG show you how TO WIN ONE OF THE PRIZES

FIRST PRIZE \$250
SECOND PRIZE \$150
THIRD PRIZE \$100
Fifty other prizes of \$10.00 each . . . \$500

Open to everyone . . . servicemen . . . amateurs . . . engineers . . . experimenters. So simple anyone can win! Complete details on how to obtain these valuable prizes found on Page ONE of the BIGGEST CATALOG IN RADIO HISTORY. Send for it immediately and get your slice of the generous awards. You can't afford to miss this wonderful opportunity! Be one of the winners . . . clip the convenient coupon now! The following well known people in the radio industry will act as judges: Dr. O. H. Caldwell . . . Editor, Radio Today; Mr. Lawrence Cockaday . . . Editor, Radio News; Mr. Joseph Reiss . . . President, Reiss Advertising Agency.

EVERYONE!! HURRY!!

Here's your lucky chance to win one of the valuable prizes we are offering! Here's your opportunity to obtain our wonderful catalog. It's FREE!! And its contents will prove invaluable to you!

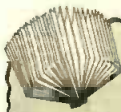

HERE'S THE GREATEST CATALOG IN RADIO!

. . . it's the biggest . . . the best . . . and it has more radio bargains packed between its covers than ever before! Imagine . . . more than 10,000 real radio "Buys" . . . at amazingly low prices! Thousands of radio parts . . . at lowest listings . . . offered by the World's Largest Radio Supply House! And NOW you can make your purchases by the WHOLESALE Easy Payment Plan. Use your equipment as you pay for it.

for the SERVICER . . . The greatest collection of up-to-date test equipment . . . over 10,000 bargains in parts, tubes, hardware . . . at prices that cannot be beaten! See this catalog . . . learn why thousands of successful servicemen buy the WHOLESALE way.



for the SOUND ENGINEER . . . Lafayette P.A. systems are made in all sizes for every possible requirement and specification . . . at prices that allow a handsome margin of profit. Complete beautiful NEW line described in detail in BIG P.A. section.



for the AMATEUR . . . Thousands of "Hams" buy the WHOLESALE way! It's the easiest . . . the swiftest . . . most reliable . . . and economical way. WHOLESALE maintains the biggest complete stocks of standard equipment to be found anywhere.



Remember!! . . . THIS CATALOG is 180 pages BIG . . . and it's FREE! Send for it today . . . get the details of the \$1,000.00 contest. See the new EASY-TO-PAY Plan now available.

SEND THE COUPON NOW

WHOLESALE RADIO SERVICE CO., Inc.
NEW YORK, N.Y. CHICAGO, ILL. ATLANTA, GA.
100 SIXTH AVENUE 901 W. JACKSON BLVD. 430 W. PEACHTREE ST., N.W.
BOSTON, MASS. BRONX, N.Y. NEWARK, N.J. JAMAICA, L. I.

WHOLESALE RADIO SERVICE CO., Inc.
100 Sixth Avenue, New York, N. Y.
Rush FREE 1938 Catalog No. 69-2K7

Name _____
Address _____
City _____ State _____

FREE
YES...
Rush my copy

Get a whole shelf-full of RADIO BOOKS

IN ONE BIG VOLUME

\$4-



- CLEAR
- COMPLETE
- UP-TO-DATE
- ECONOMICAL

The COMPLETE Ghirardi RADIO PHYSICS COURSE

One big book now takes the place of 36! Ghirardi's best-selling RADIO PHYSICS COURSE compresses the world's knowledge of radio, electricity and sound between the covers of this great 972-page volume.

WHAT YOU WILL LEARN FROM THIS BOOK. Sound, Speech and Music... Electrons... Electric Current... Electric Units and Circuits... Resistance...

TEAR OFF - FILL OUT - AND MAIL!

RADIO & TECHNICAL PUBLISHING CO. 45 Astor Place, New York, Dept. RN-107.

Send me \$4. Send my RADIO PHYSICS COURSE postpaid. (Foreign \$4.50).

Name..... Address.....

MONEY-BACK GUARANTEE

NEW NATIONAL RECEIVERS

NC-80X Receiver—Ten tubes, crystal filter, controllable, selectivity from 200 to 10,000 cycles.

NC-81X Receiver—Same as above, but a strictly amateur-band model, providing extreme calibrated bandspread on the amateur bands.

Either above receiver complete with tubes, crystal and speaker chassis.

AMATEUR PRICE \$88.00 NET COMPLETE

Write for our 1937 catalog

CAMERADIO

963 LIBERTY AVE. PITTSBURGH, PA. 30 TWELFTH ST. WHEELING, W. VA.

Established 1919

QUALITY recommends

Condensers by SOLAR

WET... DRY PAPER MICA... TRIMMER



SOLAR MFG. CORP. 599-601 Broadway New York City

RADIO PHYSICS COURSE

ALFRED A. GHIRARDI

Lesson 66. Meters

INSTRUMENTS which depend for their operation on the electromagnetic effect of the electric current are called galvanometers, and are the most common types for both d.c. and a.c. measurement work on account of their ruggedness, high degree of accuracy, simplicity and portability.

tion of the earth's magnetic field for it. The N pole of the coil will also coincide with the S pole of the compass needle in the same direction. The result is that the passage through the coil, of the current to be measured, produces a deflection of the needle around from its "zero position," the tangent of the angle of deflection thus produced being proportional to the strength of the current flowing through the coil.

We have here, a device for measuring the flow of electric current by means of the magnetic force of attraction it produces on a movable magnet at the center. This is called a galvanometer.

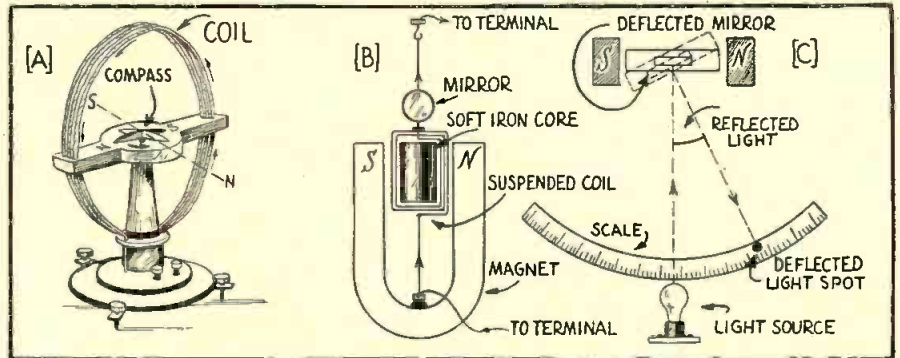

Figure 1. (A) Simple form of tangent galvanometer. (B) D'Arsonval galvanometer movement. (C) Light beam arrangement for amplifying movements of the mirror.

Probably the simplest type of magnetic current indicating and measuring instrument, is the tangent galvanometer shown at (A) of Figure 1. A description of the construction and action of this old form of instrument follows:

The tangent galvanometer consists of a vertical coil of insulated copper wire, with a small permanent-magnet compass needle mounted in a horizontal plane at its center, as shown in (A) of Figure 1. Since this compass needle is free to rotate in a horizontal plane, it will point exactly north and south in the earth's magnetic field when no current is flowing through the coil.

Now the current to be measured is sent through the coil of wire. This produces, inside of the coil, a magnetic field whose strength depends upon the number of turns of wire and the current. With the current direction shown at (A) of Figure 1, an N pole is produced at the front face of the coil and an S pole is produced at the rear, as marked. The S pole of the coil coincides with the S pole of the compass needle and makes it tend to move around in a clockwise direction, against the force of attrac-

This form of galvanometer has several disadvantages, the most important of which are as follows: (1) it is not readily portable and compact; (2) the readings are affected by any external magnetic fields which may exist around near the instrument; (3) it is not sensitive to small currents since the magnetic field produced by the current must pass through a long air path; (4) the instrument can only be used when the plane of the coil is lined up so it points N and S, and the instrument must be leveled up to permit free rotation of the compass needle every time it is used; (5) it also has the disadvantage that in its simplest form it does not return to the zero point very quickly when the current flow through the coil is stopped, and also, the needle oscillates back and forth for quite a long period of time before it finally comes to rest at any position; (6) the accuracy of its readings are also affected by changes in the earth's magnetism, which, as we know, may be severe during magnetic storms and times of "sun-spots."

W2XAD-W2XAF Increases Power

Schenectady, N. Y.—The F. C. C. has granted permission for the erection of a new 100-kilowatt transmitter to be used for either W2XAD or W2XAF. This will make the G. E. station one of the strongest in the world.

Station List

(Continued from page 221)

Call	Location	Kc.	Kw.
7LA	Launceston, Tasmania	1100	0.3
2UW	Sydney, N. S. W.	1110	0.75
4BC	Brisbane, Qnsld.	1120	1.0
6ML	Perth, W. Austr.	1130	0.5
2HD	Sandgate, N. S. W.	1140	0.5
2WG	Wagga, N. S. W.	1150	1.0
2KA	Katoomba, N. S. W.	1160	0.1
2NZ	Little Plain, N. S. W.	1170	2.0
4TO	Townsville, Qnsld.	1170	0.2
3KZ	Melbourne, Vic.	1180	0.6
2CH	Sydney, N. S. W.	1190	1.0
5KA	Adelaide, S. Austr.	1200	0.5
2GF	Grafton, N. S. W.	1210	0.1
6KG	Kalgoorlie, W. Austr.	1210	0.5
3YB	Warrnambool, Vic.	1210	0.1
4AK	Oakey, Qnsld.	1220	2.0
2NC	Newcastle, N. S. W.	1230	2.0
3TR	Sale, Vic.	1240	1.0
6IX	Perth, W. Austr.	1240	0.5
3SR	Shepparton, Vic.	1260	0.5
2SM	Sydney, N. S. W.	1270	1.0
3AW	Melbourne, Vic.	1280	0.6
4BK	Brisbane, Qnsld.	1290	0.5
2TM	Tamworth, N. S. W.	1300	2.0
5AD	Adelaide, S. Austr.	1310	0.5
3BA	Ballarat, Vic.	1320	0.5
4RO	Rockhampton, Qnsld.	1330	0.05
3SH	Swan Hill, Vic.	1330	0.1
4WK	Warwick, Qnsld.	1340	0.1
3GL	Geelong, Vic.	1350	0.1
3MA	Mildura, Vic.	1360	0.1
4PM	Port Moresby, N. Guinea	1360	0.1
2MO	Gunnedah, N. S. W.	1370	0.1
4BH	Brisbane, Qnsld.	1380	1.0
4CA	Cairns, Qnsld.	1390	0.1
6PM	Fremantle, W. Austr.	1390	0.1
2GN	Goulburn, N. S. W.	1390	0.2
2KO	Newcastle, N. S. W.	1410	0.5
3XY	Melbourne, Vic.	1420	0.6
2WL	Wollongong, N. S. W.	1430	0.3
4VL	Charleville, Qnsld.	1430	0.05
2QN	Deniliquin, N. S. W.	1440	0.1
4IP	Ipswich, Qnsld.	1440	0.1
5MU	Murray Bridge, S. Austr.	1450	0.1
7UV	Ulverstone, Tasmania	1460	0.3
2RG	Griffith, N. S. W.	1470	0.05
2AY	Albury, N. S. W.	1480	0.1
4BU	Bundaberg, Qnsld.	1480	1
3MB	Birchip, Vic.	1490	0.1
2BS	Bathurst, N. S. W.	1500	0.1
3AK	Melbourne, Vic.	1500	0.2
FIJI ISLANDS			
ZJV	Suva	920	0.4
NEW ZEALAND			
2YA	Wellington	570	60.0
4ZP	Invercargill	620	0.1
1YA	Auckland	650	10.0
3VA	Christchurch	720	10.0
2VB	N. Plymouth	760	0.1
4YA	Dunedin	790	10.0
2ZH	Napier	820	0.065
2VC	Wellington	840	5.0
1YX	Auckland	880	0.1
2ZP	Wairoa	900	0.105
2ZR	Nelson	920	0.03
3ZR	Greymouth	940	0.175
2ZF	Palmerston North	960	0.15
2ZJ	Gisborne	980	0.25
2VD	Wellington	990	0.2
4ZA	Dunedin	1010	0.02
4ZO	Dunedin	1010	0.025
4ZAI	Dunedin	1010	0.03
1ZB	Auckland	1090	0.2
2ZB	Wellington	1120	1.0
4YO	Dunedin	1140	0.2
2ZM	Gisborne	1150	0.015
2ZD	Masterton	1170	0.003
3YL	Christchurch	1200	0.2
4ZL	Dunedin	1220	0.1
2ZL	Hastings	1240	0.02
1ZM	Manurewa	1260	0.05
4ZC	Cromwell	1280	0.005
1ZJ	Auckland	1310	0.065
4ZR	Balclutha	1340	0.005
2ZO	Palmerston, North	1400	0.2
3ZM	Christchurch	1470	0.06

Announcers in Mexico

Mexico, D. F.—The Mexican Radio Laws require that announcers be licensed. They must possess the following requirements: 1. They must be Mexicans; 2. They must be authorized by the Ministry of Communications and Public Works for the performance of such duties. The respective permits shall only be given to those persons who demonstrate that they have adequate cultural preparation which will permit them to fulfill their mission.

AMAZING NEW WAY TO LEARN RADIO-TELEVISION

Fascinating work and good-pay jobs are available for the man who has had *practical* training in these important fields. And *now* you can get such training—through a method developed by experienced engineers who are themselves doing big things in Radio and Television, backed by the resources and modern facilities of one of the nation's greatest broadcasting stations, 5000-watt Columbia basic network station, KMBC.

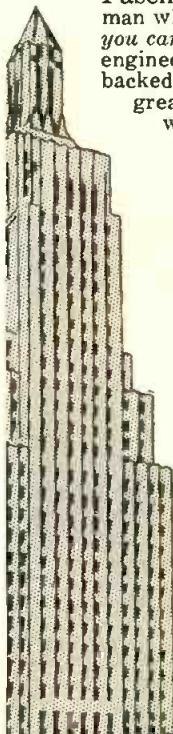

MIDLAND'S GREAT "Color-Coded" EXTENSION TRAINING

Under this new method, you perform experiments in your home that teach you step by step the fundamentals. We furnish all equipment necessary, and complete manuals. Then you get a bus ticket to Kansas City, for four weeks' intensive training in our fine new school with its thousands upon thousands of dollars worth of latest equipment. We are the only independent school having modern 441-line electronic television equipment. Graduates are qualified to take exams for two Government Licenses, and are fitted for some 50 to 60 different lines of good-pay work in radio, and for the great future opportunities in television. Lifetime employment service. Investigate right now by writing for *free book*. (We are not connected with any other Radio or Television School).

MIDLAND TELEVISION, Inc.
Floors 29, 30, 31, Kansas City Power & Light Bldg.
Kansas City, Missouri



FREE
Get this Book that tells of opportunities in Radio and Television

FORTUNES in FORESIGHT

You get 90 modern, Color-Coded lessons, 10 big shipments of equipment (to own and keep) including 3-inch Cathode Ray tube, necessary tools and 10 attractive "Home Laboratory" manuals.

MAIL COUPON FOR FREE BOOK

Midland Television, Inc., Kansas City Power & Light Bldg. 110-K W. 14th St., Kansas City, Mo.

Without obligating me, send your new FREE BOOK about Radio-Television opportunities, "FORTUNES in FORESIGHT."

Name _____ Age _____
Address _____
City _____ State _____

WANTED—MEN
to east Christmas Goods, 5 and 10c Novelties, Toy Autos, Ashtrays, etc. Can be done in any spare room and no experience necessary. A rare opportunity to devote spare or full time to profitable work.

METAL CAST PRODUCTS CO.
1696 Boston Road, Dept. 32, New York N. Y.

New Phones for the Rig
Amateurs! Check your requirements and don't forget the importance of your phones. Get new ones—get better ones—get FEATHERWEIGHTS.
For information, write Dept. R-2.
TRIMM RADIO MFG. CO.
1770 Berteau Ave., Chicago, Illinois

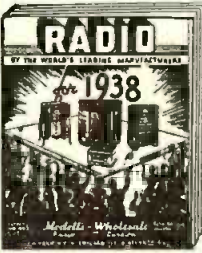

FREE!! New 1938 Radio Catalog

SERVICEMEN—Radio Salesmen and Agents—become a **MODELL** representative in your community without any investment. Earn up to \$100 a week in commissions selling Nationally Known Radios. Take orders from the largest and most complete catalog ever published, describing and illustrating the following 1938 makes: RCA—Philco—General Electric—Zenith—Motorola—Delco—Granow—Crosley—Stromberg-Carlson—Kadette—Emerson—Pada—Halsou—Gard. Join this nationwide organization by writing for particulars. Territory is now being allotted to live wire men who are anxious to earn extra money in their spare time. Write for this big catalog today.

Modell's Since 1889
AGENCY DIVISION
Write to Dept. G-6 and mail to address nearest you.
CHICAGO, ILL. ATLANTA, GA. NEW YORK, N. Y.
156 W. Washington St., 57 Forsyth St., 58 Cortlandt St.

for
**RESISTORS
DEMAND
OHMITE**

BROWN DEVILS

Vitreous Enamel—ideal for use under humid conditions.

RED DEVILS

The "safety" resistor that will take heavy overloads.

Wire Watts

The universal 1-watt resistor for use in almost any radio circuit.

DIVIDOHMS

The Vitreous Enameled Adjustable Resistor for experimental work and an excellent voltage divider.

RHEOSTATS

All-Porcelain—from 25 watts to 1000 watts.

ASK YOUR JOBBER FOR OHMITE—
WRITE FOR COMPLETE CATALOG

OHMITE
MANUFACTURING CO.
4840 Flourney Street
CHICAGO, ILLINOIS

**HERE'S THE "KEY TO
SUCCESSFUL SERVICING"**

ADVANCED HOME STUDY TRAINING FOR
**"SERVICE MECHANICS" WHO WANT
TO BECOME EXPERT SPECIALISTS**

Actually it is not a case of WANTING to become a "Service Specialist"—it is a **NECESSITY!** New developments and changes in circuit designs make it urgent for you to keep pace with the progress of Radio. The serviceman who lacks the necessary training is eliminating himself from a better position and better pay.

START TRAINING NOW FOR THE FUTURE RSI training in Radio Service and Public Address work gives you thorough, basic knowledge of how complex circuits work and what goes into modern receivers. Write today and learn all the facts.

FREE BOOKLET!
You'll want to read every page of "The Key to Successful Servicing". Write at once.

**RADIO
SERVICE INSTITUTE**
Dept. RN-10
3308 14th St., N. W.
Washington, D. C.



LEE DE FOREST RECEIVES DOCTOR OF ENGINEERING DEGREE
Radio operators the world over will be glad to hear that Dr. Lee De Forest, world-famous radio engineer, affectionately called the "Father of Present-day Radio," was honored for his research work in the invention of the vacuum tube, without which radio as it is today could not exist. Left to right: Lt. Comdr. R. H. G. Mathews, U. S. N. R., Dr. Lee De Forest, Dr. D. C. Jackson, Jr., who conferred the degree for the Lewis Institute of Chicago, and McMurdo Silver, well-known receiver manufacturer

QRD? QRD? QRD?

CONDUCTED BY GY

ANENT our discourse some issues back on the efficiency of the automatic alarm signal devices which were being perfected by the radio companies and tested under the supervision of the U. S. Government, RCA and Mackay have recently reported the first two instances this device served American vessels in successfully receiving SOS calls. Both of these companies installed this equipment, which automatically picks up distress calls when radiops are off watch and rings a bell in the shack, the ops' quarters and on the bridge. Many of these installations are being made on the new ships and on those being taken out of drydock.

THE new law which recently passed Congress along with the Copeland Ship Bill states that an operator must have had at least six months actual experience in radio work on board ship before he is permitted to take a ship out alone. This is in line with our advocacy of an "Apprentice Ticket" so that a fledgling radiop should have the practical experience of operating under the direct supervision of a First Class operator. One of the main thoughts that prompts this idea is the building up of confidence in the operator recently out of school.

Shipping is again reported to be picking up with plenty of new installations of radio equipment, auto alarms and emergency apparatus being ordered. In the Mississippi and James Rivers laid-up ships are being moved, steam lines are being hooked up and tugs lying alongside. Each new ship that gets up steam and comes from drydock means a job or jobs for radiops. CTU-Marine Division states that they have placed everyone of their members in billets and at better wages. They have been doing some active organization work and feel that the future holds great promise for increase in jobs and a better feeling between shipping men and radiops. This organization which is affiliated with the National Commercial Telegraphists' Union, has made a remarkable record in the short space of time of less than one year in signing up numerous radiops on the East Coast. There is such a spirit of camaraderie and cheerfulness in the main offices that it is a pleasure for the new members to sign on the dotted line. Here's

good luck to this organization that seems to be going places.

Some of the new uses to which radio communications are being put to: Transceiver installed on a bicycle by a S.W. fan. The receiver is of the 3-tube type and works efficiently on 5M. Then a bright Mama and Papa keeps tabs on baby daughter by placing a S.W. receiver in the child's pull-wagon. All that Mama or Papa do when they want the child in for something is grab the Xmtr Mike and bellow, "Come home, dear." Nothing like stretching the Mother's apron strings a bit, what!

For the first time, the newly formed Paramount Communication Co. will function during the filming of "Ebb Tide." Under studio ownership, the concern is permitted four radio channels, two are for studio-to-location communication and two for sea duty, and all of them will permit conversation between various location units. Equipment has been installed which will permit a hook-up between the phones on executives' desks and the radio, so that units will be no farther away than a sound stage. Radiops wanting land billets should look into this new type of installation and make contacts so that when and if other companies get this same idea they can be on the ground floor, as the saying is.

Plane-to-ground telephone service for air travelers is going to be a reality shortly. Says Croil Hunter, of the Northwest Lines, "For a number of years pilots have been equipped for ground communication, but this would be the first time in aviation

history that telephone service would be offered to aerial passengers. Each passenger will literally have a phone at his elbow throughout the entire air journey." All, of which, goes to prove that radiops and technicians who are up on their I. Q. should have very little trouble hooking up in the communication field.



As it has always been the policy of this column to be fair and open to the opinions of radiops, we throw the gates wide open to Mr. C. H. Jordan who states in a communication, that in reference to paragraphs quoted in the April issue of this medium he insists on a retraction which is hereby given. He says "That C. H. Jordan, to whom you refer as Secretary of the San Pedro local of the ARTA, received no salary whatsoever during or for the period of the strike, from the San Pedro local of the ARTA; and Jordan received no salary whatsoever from the Maritime Federation, San Pedro district, or otherwise, during or for the period of the strike. . . . And that Jordan received about \$60.00 a month for expenses from the San Pedro Local of the ARTA, but nothing whatsoever for salary. . . . And furthermore that Merv. Rathborne received no salary from the San Francisco local of the ARTA during or for the period of the strike; and likewise received no salary from the Maritime Federation, San Francisco district, during or for the period of the strike." Although we regret to have caused Mr. C. H. Jordan aggravation and inconvenience we are happy this column evinces such careful reading. And we have often remarked that it is the open forum of you radiops.

In response to a suggestion on the part of a Southern brother of the bug-guild, Brother L. W. Briggs of Utica says: "This is the matter of an organization of radio men the same as the IRE for engineers and the ARRL for the amateur operators. . . . Please understand that what I have in mind would not be to take the place of any union in the field but would have as its purpose the raising of the standards of the technicians and work for legislation for the benefit of all of us. I fully believe that the "Association of Radio Communication Technicians" can be a success if all licensed operators will put their shoulders to the wheel." We agree wholeheartedly with this idea and we would like to hear from some of "youse guys" on this subject. We thank Brother Briggs for his interest in trying to raise the standards for radiops.

Our Westcoaster beefs: "How come superhets are not in style on board some ships? With so many vessels on 600 the QRM is bad! Couldn't some of the coastal stations be spotted on 600.5 and 599.5? Anyway, QRM is too much for the 3-tubers now used. Courtesy was always the style and necessity in ye good olde days of sparks and arcs. Patience was its own reward because one cleared traffic. Also, too many Cuban stations. Foreign ships fail to observe the Silence Period. XFN calls CQ too much and you can't seem to raise him, just when you need him. When one ship's chronometer is off 30 seconds and he runs into S.P., two other ships pipe up with "AS3" making it about as silent as an air drill outside the radio shack when you have asked from NAA QSA2. . . . And how about letting the Navy QSP time ticks and weather forecasts more than is done at present? WNU could get a 50% increase in range by changing note a little. WOE needs a new receiving location. And contrary to belief Sparks still gets the QTE'S for the Skipper instead of having the mate work the Direction Finder.

(Turn to page 241)

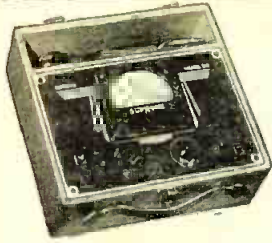
SUPREME

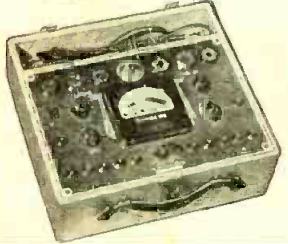
"THE FINEST PORTABLE LABORATORY EVER BUILT"

MODEL 502 TUBE and RADIO TESTER. When we say that this model is a serviceman's dream come true, we mean just that. Imagine having the Model 501 Tube Tester PLUS nineteen additional ranges and functions of .2 to 1400 A. C. volts in four ranges; .1 ohm to 20 megohms in five ranges; .2 to 1400 A. C. volts in four ranges; .2 to 1400 A. C. volts in four output ranges PLUS an Electrostatic capacity leakage test on a neon bulb and PLUS an Electrolytic filter capacity leakage test on a "Good-Bad" English reading scale. A complete, quality, tube tester and set tester in a space 10 1/2" x 5", weighing only 16 lbs. at this new low price.
Dealer's Net Cash Price \$49.95
Or, \$5.50 cash and 10 monthly payments of \$4.95

MODEL 501. Test your customers' tubes more accurately—sell more tubes! That's SUPREME'S new Electro-conductance tube tester. This excellently engineered unit tests tubes for (1) Inter-element leakage between any two elements, (2) open test in any element, (3) short check between any two elements, (4) quality test of complete tubes and (5), in the case of tubes having two or more sections, separate sectional quality tests. **5 TESTS ON EVERY TUBE!**
Dealer's Net Cash Price \$36.95
Or, \$4.00 cash and 10 monthly payments of \$3.66

MODEL 551. This extraordinary new model is not only a Set Tester but provides a method of making voltage, current and resistance readings directly from the tube socket without removing the chassis from the cabinet! Analyzes all voltages from 0.2 to 1400 volts A. C. in 4 ranges and 0.2 to 1400 D. C. volts in 4 ranges at 1000 ohms per volt. Three D. C. current ranges of 0.2 to 1400 volts A. C. Self-contained ohmmeter circuit measures 0.1 to 20 megohms in 5 ranges. 20 functions and ranges in all!
Dealer's Net Cash Price \$38.95
Or, \$4.25 cash and 10 monthly payments of \$3.86.

MODEL 541. Here is the sweetest and fastest little Set Tester ever offered a serviceman at any price. Measuring only 7 1/4 x 10 1/4 x 4 1/2" and weighing but 9 pounds, 20 ranges and functions are at your finger tips on a single selector switch. Here you have .2 to 1400 A. C. volts in 4 ranges; .2 to 1400 D. C. volts in 4 ranges; .2 to 1400 D. C. mills in 3 ranges; .2 to 1400 A. C. volts in 4 output ranges; .1 ohm to 20 megohms in 5 ranges (all self-contained)—and look at the price!
Dealer's Net Cash Price \$26.95
Or, \$4.00 cash and 7 monthly payments of \$3.67.

Sold on Supreme S. I. C. Terms—The World's Easiest Installment Terms

Write for new literature describing the complete line!

SUPREME INSTRUMENTS CORP.
GREENWOOD, MISSISSIPPI
 Export Dept., Associated Exporters Co., 145 W. 45th St., New York City
 Cable Address LDPREH, New York

Radio Beginners! See "The Inside Story" on page 253



FREE!

New LATEST CATALOG

CONTAINING HUNDREDS OF AMAZING RADIO VALUES

At New Low PRICES

NOW-GREATER SAVINGS THAN EVER

In New RADIOS and EQUIPMENT

We Carry Almost Every Radio Set Made

TREMENDOUS DISCOUNTS

on Tubes, Amplifying Equipment, Public Address Systems, Auto, Home, and Farm Radios in all Styles, Types and Voltages. We can supply you with any Manufactured Set.

ALL MERCHANDISE GUARANTEED
 Factory Sealed Cartons. No Seconds.

CHOICE EXCLUSIVE TERRITORY
 AVAILABLE TO LIVE REPRESENTATIVES

Post RADIO CORP.

72 CORTLANDT ST. DEPT. A NEW YORK, N.Y.



RCA 67M1
 1938
AUTO SET
 LIST \$54.95
50% off

The LAST WORD in PERFORMANCE . . .
the last word in long life!

Model 321

TUBE-TESTER MULTITESTER

\$49.50



Whatever you pay for a tube tester-multitester, you can't duplicate the comprehensiveness, the engineering, the performance of Radio City's new model 321. Just consider these features:

Tube tester provides the most modern R.M.A. load, separate function, open, short, leakage tests. Absolutely free reference full floating filaments. Hum and noise tests. Double fuse protection for meter as well as entire tester. Multitester tests condenser leakage, opens and shorts, for electrolytic, paper and mica types. 5 range AC voltmeter 0.5-25-125-500-1250. 5 range DC voltmeter 0.5-25-125-500-1250. 5 range ohmmeter—low 1/20 ohm to high 30 megohms. Current—6 ranges—low 10 microamps, high 25 amps for vibrator testing. D. B. measurements from down 15 to up 40. 5 output ranges. Protected against burnout—and protected against getting out of date.

You Couldn't Get Better Performance in a

SIGNAL GENERATOR

if you paid twice the price

Model 701

\$29.95



And that's no exaggeration—because the workmanship and design in new Model 701 Signal Generator are the last words in engineering. Attenuation from 1 micro-volt to 1/2 volt constant impedance ladder net work 5 steps. Sturdy construction; attractive design. Output for cathode ray, modulation. Direct reading 4 1/2" dial. Multicenter frequency bands, 125 kilocycles to 60 megacycles. Provision for external modulation. Automatic shorting of coils not in use prevents influence of dead spots, etc. Electrostatically shielded power transformer. Separately shielded coil assembly, attenuator and R. F. Circuits.

See Your Jobber. Write to Dept. N. for Catalog

RADIO CITY PRODUCTS CO.

88 PARK PLACE NEW YORK CITY "DEPEND ON DEPENDABLE"

IF IT'S TOUGH - DON'T CUSS
Turn To RADIO-KINK-AIDS

Practical Repairs For Over 3000 Hard-To-Fix Radios.

Just pull out the card corresponding to the name and model of the set you are repairing, and there you have listed the service troubles found in that radio and how to fix them. Yes it's as simple as that.



ONLY \$1.95
 COMPLETE WITH METAL CABINET

FREE WRITE FOR BULLETIN RADIO AND SAMPLE CARD
AKRAD PRODUCTS CO.
 352 WOOSTER AVE Akron, O.

Tear out this ad, write your Name and Address in the margin, send \$1.95 and we will send outfit at once.

RADIO ENGINEERING

RCA Institutes offer an intensive course of high standard embracing all phases of Radio. Practical training with modern equipment at New York and Chicago schools. Also specialized courses and Home Study Courses under "No obligation" plan. Catalog Dept. RN-37.

RCA INSTITUTES, Inc.
 A Radio Corporation of America Service
 75 Varick St., New York 1154 Merchandise Mart, Chicago

RADIO-EMISORAS BROADCASTINGS

C LONG WAVE ONDA LARGA **C**
 250 W. **M** **O** 1000 W.
 1120 Kc. **G** **F** 11800 Kc.

Nos complacemos a Vd. **MATANZAS CUBA** **G** We are pleased to notify you that your report of our Program es correcto. *Permisi de la para de hoy es correcto.*

Muy agradecidos,

The DX Corner (Short Waves)

(Continued from page 226)

"AKASH VAWI", Deccan Plateau, South India, 49.6 meters, (Hodgkyns).
 HS8PJ, Bangkok, Siam, 9350 kc., heard 8-9 a.m., operates Monday and Thursday, (Poll).
 UPOL, North Pole, 16720 kc., Soviet station at North Pole, (Unger).

South America

HJ4ABD, Medellin, Colombia, 5900 kc., daily 4-11 p.m., (Hartzell).
 HJ4ABH, Armenia, Colombia, 9520 kc., daily 7-10 p.m., (Alfred, Eder, Shamleffer, Bauer) 8-11 a.m., (Doyle). Slogan: "La Voz de Armenia."
 HJ4ABE, Medellin, Colombia, 6097 kc., heard 6 p.m., (Westman) 7-12 p.m., (Doyle).
 HJ4ABN, Armenia, Colombia, 9520 kc., 7-10 p.m., (Augustine) signed at midnight, (Doyle).
 OAX4J, Lima, Peru, 9330 kc., heard 8-12 p.m., (Alfred, Shamleffer) 9520 kc., 12-3 p.m. and 5 p.m.-1 a.m. (from veri.), (Ralat, Hendry, Kemp, Doyle). Slogan: "Radio Nacional". Address: P. O. Box 1166.
 OAX5B, Ica, Peru, 11795 kc., (Shamleffer) 4-11 p.m., (Gossett) daily.
 OAX1A, Chiclayo, Peru, 6174 kc., 8-11 p.m., and Sunday 8-12 p.m., (Schrock). Slogan: "Radio Nacional"; "Radio Delcar". Address: Casilla 9.
 OAX4P, Huancayo, Peru, 6122 kc., irregular, (Schrock) 5975 kc., 9-11 p.m., (Bauer).
 HJ2ABD, Bucaramanga, Colombia, 9635 kc., heard 7-10:30 p.m., (Gossett) 11:30 a.m.-12:30 p.m., (Doyle).
 HJ2ABC, Cucuta, Colombia, 9575 kc., 8-12 p.m., (Gossett, Doyle).
 HJ3ABD, Bogota, Colombia, 6000 kc., daily except Sunday 7-11 p.m., (Hartzell).
 HJ1ABB, Barranquilla, Colombia, 4780 kc., heard irregular, 7-10 p.m., (Alfred, Diez) 9575 kc., 11:30 a.m.-1 p.m. and 4:30-6 p.m., (Doyle). Slogan: "La Voz de Barranquilla". Address: P. O. Box 715.
 HJ1ABP, HJ1ABR, Cartagena, Colombia, 9620 kc., daily at 7 a.m., and 6-10 p.m., (Alfred, Gossett, Eder, Ralat) 9000 kc., (from ann.), (Shamleffer, Wittig, Hendry) 6030 kc., 11 a.m.-1 p.m., Sunday 10 a.m.-1 p.m. and 3-6 p.m., (Doyle). Slogan: "Radio Cartagena." Address: P. O. Box 37.
 HJ1ABE, Cartagena, Colombia, 9505 kc., daily 6-10 p.m., (Alfred, Chandler). Address: P. O. Box 31.
 HC2RL, Guayaquil, Ecuador, 6624 kc., Tuesday 9-11 p.m., and Sunday 5:30-7:30 p.m., (Hartzell).
 PRADO, Riobamba, Ecuador, 6625 kc., heard Thursday 9:30-11:30 p.m., (Alfred).
 HC2JSE, Guayaquil, Ecuador, 7854 kc., heard 7 p.m., (Ralat) daily 9 a.m.-2 p.m. and 4-11 p.m., (from veri.), (Magnuson, Hartzell). Slogan: "Ecuador Radio."
 HC1EC, Quito, Ecuador, 8600 kc., 8-10:30 p.m., (Schrock).
 LSX, Buenos Aires, Argentina, 10350 kc., heard 9 p.m., (Alfred) heard Monday and Friday 5-6 p.m., (Gossett). Friday and Thursday 8-9 p.m., (Dressler, Doyle). Slogan: "Transradio Buenos Aires."
 LRX, Buenos Aires, Argentina, 9600 kc., daily 5-10:30 p.m., (Alfred, Eder, Hendry) 9708 kc., (Diez). Slogan: "Radio El Mundo." Address: P. O. Box 555.
 LRU, Buenos Aires, Argentina, 15290 kc., heard irregular, (Gossett, Schrock) 15250 kc., (Diez). Slogan: "El Mundo."

A CUBAN BROADCASTER
 Verification card from COGF, received by Observer Patrick, of Cambridge, Mass. They use the same card for long and short-wave verifications.

YV1RL, Maracaibo, Venezuela, 5930 kc., heard 9:15 p.m., (Ralat) daily 4:45-9:45 p.m., (Hartzell, Eder, Doyle). Slogan: "Radio Popular." Address: P. O. Box 247.
 YV1RD (ex YV7RMO), Maracaibo, Venezuela, 6070 kc., heard 5-10 p.m., (Schrock). Address: P. O. Box 100.
 YV1RA, Maracaibo, Venezuela, 5930 kc., signed Monday 9:33 p.m., (Shamleffer).
 YV1RI, Coro, Venezuela, 6210 kc., (from veri.) (Williams, Eder) 7-10 p.m., (Augustine, Doyle). Slogan: "Radio Coro."
 YV1RH, Maracaibo, Venezuela, 6350 kc., heard 9:08 p.m., (Eder) 6370 kc., heard 11 a.m.-2 p.m. and 5-11 p.m., (Doyle).
 YV5RC, Caracas, Venezuela, 5800 kc., daily 8 p.m., (Fleming) heard 9:30 p.m., (Eder) 7-8 a.m. and 4-9:30 p.m., (Doyle). Slogan: "Radio Caracas."
 YV5RJ, Caracas, Venezuela, 6230 kc., heard 10:25 p.m., (Eder) 6350 kc., heard 8-11 p.m., (Doyle).
 YV5RH, Caracas, Venezuela, 6400 kc., heard 9 p.m., (Augustine, Doyle).
 YV4RB, Valencia, Venezuela, 6520 kc., heard 5:15 p.m., (Ralat) 6490 kc., daily 6-10 p.m., (Hartzell).
 YV4RH, Valencia, Venezuela, 5917 kc., 6-10 p.m., (Augustine).
 YV4RD, Maracay, Venezuela, 6300 kc., daily except Sunday 6-10 p.m., (Hartzell).
 YV6RC, Bolivar, Venezuela, 6420 kc., 6-10 p.m., (Augustine, Doyle).
 YV5RP, Caracas, Venezuela, 6290 kc., heard irregular, (Doyle).

SIX YEAR OLD RADIO FAN
 Frank Sakely, Jr., has had his own all-wave radio receiver, built by his dad, since he was only a little tot of three.



YV4RG, Maracay, Venezuela, 6300 kc., heard 8:10-9:30 p.m., (Doyle).
HP5K, Colon, Panama, 6065 kc., schedule: 8:30-10 a.m., 12:30-2 p.m., 7-12 p.m., (from ver.). (Fallon, Diez).
HP5B, Colon, Panama, 6030 kc., daily 7:30-10:30 p.m., (Doyle).
HP5A, Panama, Panama, 11700 kc., heard Tuesday 9 p.m., (freq. from ann.) (Dressler) heard 8:30-10 p.m., reports requested. (Stabler, Unger) 6122 kc. (Nigh). Address: P. O. Box 1571.
HP5I, Aguadulce, Panama, 11800 kc., 7-9:30 p.m., (Gossett).
HP5J, Panama City, Panama, 9615 kc., heard 6:10-9:30 p.m., (Gossett, Shamleffer) 9590 kc., (Hendry, Diez) heard 12:1-30 p.m., (Doyle).
HP5H, Panama City, Panama, 6050 kc., heard irregularly, 7-10 p.m., (Schrock).
VP3MR, Georgetown, British Guiana, 6070 kc., daily until 9 p.m., (Hartzell) 6061 kc., (Baner). Slogan: "The Voice of Guiana".
PRF5, Rio de Janeiro, Brazil, 9501 kc., heard 4:45-5:45 p.m., (Alfred, Gossett).
PPQ, Pernambuco, Brazil, 11670 kc., signed Friday 8:30 p.m., (Shamleffer).
CB615, CFB, Santiago, Chile, 12300 kc., (from ver.), heard 7-8 p.m., (Alfred), 4-8 p.m., and Sunday 4-10 p.m., (Gossett, Smith, Black). Slogan: "Radio Service." Address: P. O. Box 761.
CB960, Santiago, Chile, 9600 kc., heard Sunday 2-4 p.m., (Alfred) daily 10-12 p.m., (Gossett). Slogan: "Radio Pilot." Address: Casilla 1342.

North America

W2XAF, Schenectady, N. Y., 9530 kc., 8:10 a.m. (Alfred); daily 4-12 p.m. (Sokolovsky, Chandler, Harley, Diez). Slogan: "Voice of Electricity".
KKQ, Bolinas, Calif., 11950 kc., 7-10 p.m. (Alfred); 12:30 a.m. (Harley, Mott, Black).
W2XAD, Schenectady, N. Y., 15530 kc., daily 10 a.m.-6 p.m. (Sokolovsky, Chandler, Beard, Margrie); 16300 kc., (Diez, Law).
W2XE, New York, N. Y., 11830 kc. (Chandler); 6-9 p.m. (Nigh); 15270 kc. (Anca, Law, Duncan).
W3XAL, Boundbrook, N. J., 17780 kc., (Chandler); Tuesday 7:30-8 p.m. (Welper); signed 10 p.m. (Shamleffer, Marshall, Duncan, Diez).
W1XAL, Boston, Mass., 11790 and 15,000 kc., Monday, Tuesday and Wednesday 10 p.m. (from announcement) (Welper); 15250 kc., daily 3:30-4 p.m. (Hartzell).
W9XF, Chicago, Ill., 6100 kc., 10:05 p.m. (Shamleffer); desires reports. (Duncan, Law).
W3XES, Baltimore, Md., 35600 kc., 8 a.m.-5 p.m. (from ver.). (Randle).
W3XKY, York, Pa., 32000 kc., daily 8-12 p.m. (Unger).
XEWW, Mexico, D. F., Mexico, 9495 kc., 8-12 p.m. (Alfred); 15180 kc. Rooster crows at intervals. (Messer, Eder); 4:30-6 p.m. (Atherton, Schrock, Shamleffer); relays XEW (Angustine); 15165 kc., four chimes used as signal. (Kemp, Diez); 3-6 p.m. (Alfred, Anderson). Slogan: "The Voice of Latin America." Address: P. O. Box No. 2516 (from ver.).
XEAW, Vera Cruz, 15165 kc. (Schrock); daily 8-11 a.m. & 3-6 p.m. (Dressler).
XEBM, Mazatlan, Mexico, 15300 kc., Sunday 3:30-6 p.m. Four chimes each quarter hour and rooster crows on the hour. (Alfred); 15440 kc. (Anca).
XEWI, Mexico, D. F., Mexico, 11900 kc., 9-11 p.m. and irregularly. (Alfred); Monday, Wednesday, Friday and Saturday 9-12 p.m. (Gossett); 6015 kc. (Diez, Black).
XEBR, Hermosillo, Sonora, Mexico, 11820 kc., 9-12 p.m., relays XEBH. (Alfred, Gossett); 11850 kc. (Shamleffer, Black). Address: P. O. Box No. 68.
CJRX, Winnipeg, Manitoba, Canada, 11720 kc., daily 5-10 p.m. (Alfred, Wicks); daily 6-11 p.m. (Marshall, Duncan, Vollenschlager); 11730 kc. (Black). Address: James Richardson & Sons, Ltd.
CFRX, Toronto, Ontario, Canada, 6070 kc., 7-10 p.m.; relays CFRB. (Alfred). Address: Roger Majestic Corp.
CJRO, Winnipeg, Manitoba, Canada, 6150 kc. (Wicks); daily 6-11 p.m. (Marshall, Duncan).

Central America

HRN, Tegucigalpa, Honduras, 5875 kc. (Shields). Address: Box 772, Santa Barbara, Calif.
TILS, San Jose, Costa Rica, 5900 kc., 10:20 p.m. (Eder, Williams). Slogan: "Para Ti". Address: P. O. Box No. 3 (from ver.).
TIOW, Puerto Limon, Costa Rica, 6500 kc., daily 12:1-30 p.m. (Doyle).
TI4NRH, Heredia, Costa Rica, 9620 kc., 8:30-10 a.m. and 11:30-12 p.m. (Gossett).
TI2H, San Jose, Costa Rica, 5813 kc., 7-11 p.m. (Schrock).
TIPG, San Jose, Costa Rica, 6410 kc., Friday 1 a.m. (Hartzell, Diez, Doyle).

West Indies

COJK, CO9JK, Camaguey, Cuba, 8665 kc., daily 8-11 p.m., relays CMJK, 7800 kc. (Alfred, Eder, Shamleffer); daily 7:30-9:30 p.m. (Dressler); formerly CO9K. (Nigh, Hendry). Slogan: "Radio Zenith".
COCF, Matanzas, Cuba, 11800 kc., daily 1:30-



The World's Finest Radio Receiver

—IS ALSO THE MOST ECONOMICAL

Any radio that falls just short of being what you desire—is the receiver you cannot afford to buy.

Buy once and buy wisely.

The new MASTERPIECE VI is actually years ahead of the finest commercial receiver for the obvious reason that built, as it is, one at a time by engineers—features can be incorporated that are impractical for mass production. Send the coupon for complete technical details of this extraordinary new receiver.



Now Ready—1938 MASTERPIECE VI—Write For the Exciting Details

INTERPLANETARY SPACE SCOUT

A Title Won by Robert Rossi, Philadelphia, Pa.

who verified over 110 stations heard—every one over 6,000 miles distance—in the International Short Wave DX Contest, using a MASTERPIECE.

The Individually Custom Built Radio

Television Fans! See "The Inside Story" on page 253

McMURDO SILVER CORPORATION

2900-A So. Michigan Avenue
Chicago, Ill., U. S. A.

MAIL ME INTRODUCTORY OFFER WITHOUT OBLIGATION

Name.....

Address.....

CRYSTAL HEAD PHONES
SOUND CELL MICROPHONES

Information on request
THE BRUSH DEVELOPMENT CO.
 3311 PERKINS AVE • CLEVELAND, OHIO

LOW PRICED! EASY TO ERECT! STEEL ANTENNA TOWER

60¢ I. e. h. Sioux City Iowa

HAMS!—Here's the ideal antenna tower—can also be used as a vertical radiator. Strong! Light weight! Extremely rigid! Comes in 20 ft. sections, with 5 ft. tip, knocked down, for building towers 25, 45, 65, 85, or 105 ft. high, as you wish. Easy to erect. Easy to climb.

Tower Legs—1/8" x 1-1/4" x 1-1/4" x 20 ft. Low carbon rail steel angle. Galvanized after fabrication.

Cross Bars—1/8" x 3/4" x 12-3/4" mild steel, spot welded to form X brace. Baked black enamel.

Bois—1 1/4" USS x 3 1/4"—1095 steel, cadmium plated. **Guy Wire**—300 ft. No. 8 galvanized with each 20 ft. section. Tower weighs 4 1/2 lbs. per foot when assembled.

Order Direct From
WINCHARGER CORPORATION
 Dept. RN-10
 Sioux City, Iowa

DON'T BUILD OR MODERNIZE WITHOUT THE



Meissner 112 Instruction Book

Containing complete detailed wiring instructions, diagrams, schematics, pictorial diagrams, chassis layouts, alignment data and operating instructions for:—

16 MODERN CIRCUITS

Ranging from the latest 4-tube AC-DC circuit to the ultra-modern 14-tube Communications receiver using B.F.O., Crystal Filter, Noise Silencer, Band Expansion, etc., etc.

4 ADAPTER UNITS

Consisting of Beat Frequency Oscillator, Noise Silencer, Phonograph Oscillator and the Meissner Remote Control units. All self-powered.

Available at All Leading Jobbers **50¢** Net Price

MEISSNER MFG. CO.
Mt. Carmel Illinois

CODE—TAPES FOR EVERY NEED



For Example: Always Tapes You can easily learn or improve your Radio or Morse Code—typical messages are sent you by the INSTRUCTOGRAPH, at any speed. Senior model with 10 tapes and Book of Instructions—\$20.25 (Rented at low cost.) Junior model with 5 tapes and Book of Instructions—\$12.00 (Not rented). Complete oscillator equipment, test battery, \$6.50. Send for full information today to—

INSTRUCTOGRAPH CO., Dept. NR-10, 912 Lakeside Pl., Chicago, Ill. Representatives for Canada: Radio College of Canada, 863 Bay St., Toronto.

HALLIGRAFTER and R.M.E. SHORT WAVE RECEIVERS—MICRO PHONES—VIBROPLEXES—TAYLOR TUBES Cash or Terms.

Correspondence Courses in RADIO and ELECTRICAL ENGINEERING

FREE! Send name quick for free copies of school catalog, student magazines, complete details. SEND NOW! LINCOLN ENGINEERING SCHOOL, Box 931-42, Lincoln, Neb.

The DX Corner (Short Waves)

(Continued from previous page)

10 p.m., relays CMCF, 11200 kc. (Alfred, Messer, Eder, Ralat, Dressler, Schrock, Fallon, Magnuson, Shamleffer, Gross, Roberts, Mott, Duncan, Hamilton, Kemp, Black, Nigh). Slogan: "Radio Philco". Address: P. O. Box No. 51.

COCO, Havana, Cuba, 6750 kc. (Chandler, Wicks, Wollenschlager); relays CMQ, 12 midnight (Wittig); 4 p.m. (Westman, Eder); daily 6:40 a.m.-1 a.m. (Nigh, Duncan, Diez, Doyle).

COCH, Havana, Cuba, 9428 kc. (Chandler); 7 and 1 a.m. (Ralat, Wicks); 3:30 p.m. (Westman, Eder, Duncan); 9530 kc. (Diez, Doyle).

COCX, Havana, Cuba, 11490 kc. (Chandler, Wicks); 10 a.m. (Westman); 10:44 p.m. (Eder); 11500 kc. (Nigh); 4-12 p.m., 11600 kc. (Black).

CBC, Havana, Cuba, 9364 kc., daily until 12:30 a.m. (Hartzell); 9380 kc. (Markuson, Diez); 9070 kc. (Kemp); 9150 kc. (Alfred). Addresses: P. O. Box No. 132 and P. O. Box No. 866.

COCO, Havana, Cuba, 6010 kc., midnight (Smith); 4:30 p.m. (Westman, Diez); 4:7 p.m. and 8-10 p.m. (Doyle).

COD, Havana, Cuba, 6130 kc., 5 p.m. (Westman); 9:50 p.m. (Eder, Hendry).

HH3W, Port-au-Prince, Haiti, 9645 kc., 7-8 p.m. (Gossett, Nigh, Doyle).

HH2S, Port-au-Prince, Haiti, 5920 kc., 9:50 p.m. (Eder); 6-8 p.m. (Sporn, Shamleffer).

PJCI, Curacao, Dutch West Indies, 5930 kc. (Curriel); 5960 kc., 7-9 p.m. (Ralat).

Radio-Fort-de-France, Martinique, French West Indies, 9360 kc., 10:15-10:30 p.m. (Shamleffer); daily 11:30 a.m.-12:30 p.m. and 6:15-8:15 p.m. and 9-10 p.m. (Hodgkyns).

HIN, Trujillo, Dominican Republic, 12485 kc., 6-11:30 p.m. (Gossett); 6243 kc., 5 p.m. (Ralat, Fuller, Eder); 12500 kc. (Birnie, Smith); 12600 kc. (Hamilton).

HIT, Trujillo, Dominican Republic, 6630 kc., 4:30 p.m. (Ralat); daily except Sunday 12:10-1:40 p.m. and 5:40-8:40 p.m. (Doyle).

HIZ, Trujillo, Dominican Republic, 6310 kc., 6:45 p.m. (Ralat); 5:30-9 p.m. (Hartzell, Doyle).

HI2X, Trujillo, Dominican Republic, 11960 kc., relays HIN, Tuesday and Friday 8-10 p.m. (Alfred, Gossett, Fallon, Augustine, Doyle). Slogan: "La Voz de Hispaniola".

HI1X, Trujillo, Dominican Republic, 6340 kc., Sunday 7:40-10:40 a.m., Tuesday and Friday 12:10-1:10 p.m. and 8:10-10:10 p.m., rest of week 12:10-1:10 p.m. (Sokolovsky, Doyle).

HI3X, Trujillo, Dominican Republic, 15270 kc., 12-1 a.m. and Sunday 7-10 a.m. (Gossett); 15228 kc. (Diez).

HI4D, Trujillo, Dominican Republic, 11960 kc., Tuesday and Friday 8:10-10:10 p.m. (Doyle).

HI2D, Trujillo, Dominican Republic, 6900 kc., 4:6-50 p.m. (Hartzell); until 11 p.m. (Augustine, Doyle).



EXPERIENCED S. W. DX'ER

Official Observer H. Westman, of Huguenot, Cape, South Africa, knows his short-wave DX'ing and always has high praise for the short-wave dope in Radio News.

HI8A, Trujillo, Dominican Republic, 6450 kc., Saturday 9:40-10:40 p.m., Sunday 2:40-4:40 p.m. and week days 8:40-10:40 p.m. (Doyle).

Readers Who Are Awarded "Honorable Mention" for Their Work in Connection with This Month's Short-Wave Report

B. Kashimoto, R. J. Abbott, Jose Perez, Herman Ruppert, Flavio Mascarenhas, Gustave A. Magnuson, H. E. Wittig, Elmer Duncan, Leslie Mott, Vincent M. Poll, Albert Augustine, Erroll R. Birnie, Oscar Westman, N. C. Smith, H. B. Sargent, Thomas P. Jordan, Clarence Hartzell, Edward De Laet, James Nigh, Jr., N. Hendry, Edward J. Margrie, James Eichenberg, J. R. Hodgkyns, Carl & Anne Eder, Frank Couceyro, Thomas Randle, D. A. Harley, Jr., Dean Noyes, W. Beard, R. C. Messer, Fred W. Alfred, Warner Howard, Reuven Sokolovsky, Steve Beno, J. Burton, Joseph W. Brumfield, Fred Baines, Edwin David Michener, Wallace Howe, Elbert Gross, Wayne E. Wicks, Lee Meade Williams, George M. Fleming, Wilbur Muhlhans, Currie Chadwick, Warren H. Stark, Phill Fitzsimons, P. L. Patrick, Virgil Gossett, E. R. Rances, Clair D. Van Meter, Jerome Roberts, J. Weiss, John S. Dunn, William L. Bauer, H. Kemp, Raymond Hernday, Chris Davis Jaffe, R. F. Shamleffer, Leslie Madansky, Kenneth Dressler, M. J. Markuson, J. Wendell Partner, Harold E. Schrock, Thomas Fallon, Jr., Jorge Ralat, Irving Sporn, Earl G. Marshall, Fred Atherton, Troy Welper, Pete Chagaris, George Hare, Wells Gresham, Fletcher W. Hartman, W. J. Stillman, Burrell Unger, Peyton Black, Clarence M. Meyers, Augusto Anca, Leon Stabler, Anton J. Cincel, E. R. Anderson, Ernest Law, Arthur B. Coover, G. C. Gallagher, Alfred A. Smith, H. Westman, Robert L. Blanchard, Jr., Luis Diez, James J. Doyle, Arthur Hamilton, Ingvar Gullberg.

Movie Sound

(Continued from page 219)

terminal posts with white vaseline or "Non-Oxide" grease.

Check voltage of grid and plate batteries, replacing those 10 percent below rated voltage. Solder connections to all batteries (except the storage batteries) and all connections between various batteries of a group.

Clean all fuses and fuse clips in battery-switching and charging panels. Tighten clips. Check fuses for high resistance by measuring the voltage drop across each fuse.

Check a.c. supply to amplifiers, rectifiers, etc. Many of these units have one of the a-c. terminals designated for connection to the grounded side of the line; be sure that this polarity is maintained.

Check a-c. lines for proper grounding, especially if there is a voltage regulator for the equipment. These regulators are often only tapped transformers, frequently installed with no regard to proper grounding on the load side of the regulator.

The servicing of low-voltage rectifiers, such as those used to supply horn unit field current, exciting lamp current, etc., is

chiefly the replacement of defective Tungar tubes (or copper-oxide rectifier units), electrolytic filter condensers, etc.

In addition to the usual attentions to cleaning commutators, brushes, etc., motor-generators require careful adjustment of the brushes to assure a minimum sparking. Generators sometimes introduce a high-pitched whistle into the system (about 1200 cycles) which can often be eliminated by connecting a high-capacity electrolytic condenser across the output of the generator, in addition to the usual filter. Occasionally, grounding the frame of the generator may be of value in reducing noise, but it is well to steer clear of promiscuously grounding everything to reduce noise. All loose connections must be corrected.

Amplifiers

Clean all tube prongs and socket contact springs with a rubber eraser and carbon tetrachloride, a file or sandpaper must never be used for this cleaning. Where necessary, adjust socket springs to assure good contact.

Clean rheostats, gain controls, etc., with carbon tetrachloride; then cover contact areas with a thin film of white vaseline. If still noisy, pig-tails should be installed.

Push-pull amplifiers may develop a.c. hum as a result of mis-matched tubes.

The usual method of correction is to select tubes having the same plate current.

Many amplifiers have been found in which wires carrying a-c. formed a loop around one of the inter-stage or input transformers. The resulting hum has frequently been entirely eliminated by removing the loop. Complete re-wiring of the filament circuits may be necessary in such cases.

Miscellaneous Parts

In general, the horn circuits are not a source of noise, except as a result of loose or dirty connections. Fader contact points, switch points and other contacts in the speech and power circuits should receive the same attention as rheostats and gain controls.

Dust should be blown or wiped from all amplifiers and other parts, especially from terminal plates, etc. It should be a point of pride in one's work to leave the equipment as spotlessly clean as possible.

Exciting lamps should be checked for sagging filaments. Inspect photocells to make certain that the connections are clean and tight and the cell properly located. The "window" should be turned so that it receives the full beam of light from the aperture.

The question of grounding a system is one requiring some study. It cannot be a hit-or-miss proposition. Systems using batteries for filament supply in the voltage amplifiers usually have one side of the filament battery grounded. In all a-c. systems, the negative side of the plate supply and, of course, one side of the a-c. line are grounded. In general, there should be but one ground for the entire system. More may result in the formation of a closed loop over which there may be an appreciable voltage drop. This causes noise pick-up, either by induction or by directly introducing spurious voltages in the circuits. *Examine the system carefully for grounds and if in doubt, remove all grounds, check the noise level, then try each ground separately, retaining the one which gives minimum noise.* However, be careful to comply with all electrical code requirements.

Re-locating the audio transformers to reduce hum is one point which was not discussed under the heading of "Amplifiers" because it should be a "last resort" measure. This is usually a complicated job, involving many measurements of noise level and the procurement of special mounting plates for the transformers. Sometimes rotating the transformer 90 degrees and remounting results in some improvement. Some require a counter-clockwise rotation of 57 degrees—reminiscent of the "sacred angle" for neutrodyne coils!—and others a rotation of 68 degrees. It is obvious that the job is entirely one of "cut and try." Special transformers are now available which are designed for low hum pickup.

In conclusion, it may be pointed out that an intelligently conducted noise reduction program should result in dropping the over-all noise level from 12 to 20 DB.

U. S. W. Transmitting Tube

Bloomfield, N. J.—A new tube, type WL461, of radically new construction was announced by Westinghouse recently. This tube is intended for use as an oscillator in radio-therapy apparatus and other high-frequency applications. It has no press or base; the elements are supported by short, heavy rods terminating in metal thimbles. Inter-electrode capacity has been reduced as well as the electron transit time. It will deliver optimum output (400 watts for two in push-pull), at frequencies up to 50 mc. and somewhat reduced output up to 100 mc. The filament requires 5 volts at 11.5 amperes; plate supply 2000 volts at 250 ma.

..... Endorsed
By Leading Service Organizations

★ ★
HIGHEST QUALITY
★ ★
HIGHEST PROFIT
★ ★
FREE EQUIPMENT

NATIONAL UNION RADIO TUBES

National Union manufactures a complete line of radio tubes—glass, metal and G-type. National Union's high quality has made them outstanding favorites in the radio service profession. All sales policies have been formulated with the idea of making National Union radio tubes the ideal replacement tube for the radio dealer. This has been backed up with a selling program that means real support and help to the wide-awake dealer. Dealers and jobbers handling National Union radio tubes are the leaders in repair parts and service.

Free Equipment Includes:

Tube testers, set analyzers, oscillographs, signal generators, modulators, meters and other servicing instruments. In shop equipment items available include stock cabinets, coats, display signs, electric clocks, etc. All items absolutely free the National Union Way.



This "Sign of Efficiency" Can Help You Too. Get It **FREE** from N. U.

The National Union Way
Through National Union's help, radio service dealers everywhere have been able to set up better equipped shops to do better work; also to obtain merchandise helps that produce more customers. National Union have constantly put the latest advances in scientific equipment as well as modern selling aids within reach of the service dealer. The National Union Deal calls for a dealer deposit which is rebated when the specified number of tubes have been purchased. Over 70,000 completed deals. Every service dealer should investigate.

SEE YOUR JOBBER

THE ROAD TO BETTER BUSINESS

1. Full guarantee on highest quality radio tubes.
2. Cut price business not solicited.
3. Price Protection.
4. N. U. jobber stocks are complete...No hunting for odd types.
5. Timely business building aids.

Clip! Mail Now!

NATIONAL UNION RADIO CORPORATION
570 Lexington Ave., New York City RN-1037

Tell me how I can get the Sign of Efficiency Free. I am also interested in the following equipment.....

Name

Address

City State

Radio Book Free! See "The Inside Story" on page 253

The New ALLMETER
for Rapid, Accurate Measurements **\$10.40**

90-130 v. 60 cy. operation
The ALLMETER is a multi-purpose meter, 1,000 ohms per volt, d'Arsonval movement, for measuring a.c. and d.c. volts, a.c. and d.c. currents, capacity, decibels, resistance and inductance.

Volts and milliamperes, 15-15-750 (a.c. and d.c.).
Capacity, .01-50 mfd., including electrolytics.
Decibels, for total change of 42 db.
Resistance, .03-500 and 500-500,000 ohms.
Inductance, 5 to 1,000 henries.

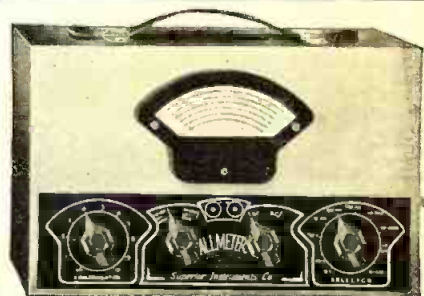

The Allmeter, 21 instruments in one.

ORDER DIRECT FROM SUPERIOR INSTRUMENTS CO. 136 Liberty St., New York, N. Y. Dept. RN-10
Send for our free Catalogue PV, in colors, describing our complete line.

Now—a high-powered—



New
The Library now comprises a revised selection of books culled from latest McGraw-Hill publications in the radio field.

Radio Engineering Library

—especially selected by radio specialists of McGraw-Hill publications

—to give most complete, dependable coverage of facts needed by all whose fields are grounded on radio fundamentals

—available at a special price and terms.

These books cover circuit phenomena, tube theory, networks, measurements, and other subjects—give specialized treatment of all fields of practical design and application. They are books of recognized position in the literature—books you will refer to and be referred to often. If you are practical designer, researcher or engineer in any field based on radio, you want these books for the help they give in hundreds of problems throughout the whole field of radio engineering.

5 volumes, 3064 pages, 2000 illustrations

1. Glasgow's PRINCIPLES OF RADIO ENGINEERING
2. Hund's PHENOMENA IN HIGH-FREQUENCY SYSTEMS
3. Chaffee's THEORY OF THERMIONIC VACUUM TUBES
4. Terman's MEASUREMENTS IN RADIO ENGINEERING
5. Henney's RADIO ENGINEERING HANDBOOK

10 days' examination. Special Price. Monthly payments. \$25.00 worth of books cost you only \$23.50 under this offer. Add these standard works to your library now—pay small monthly installments, while you use the books.

SEND THIS ON-APPROVAL COUPON

McGraw-Hill Book Co., Inc.
330 W. 42nd St., New York, N. Y.

Send me Radio Engineering Library, 5 vols., for 10 days' examination on approval. In 10 days I will send \$2.50, plus few cents postage, and \$2.00 monthly till \$23.50 is paid, or return books postpaid. (We pay postage on orders accompanied by remittance of first installment.)

Name.....
Address.....
City and State.....
Position.....
Company..... RN-10-37

MILLION TUBE TESTER



FEATURES

1. Emission
2. Metal Tubes
3. Shorts Hot
4. Leakage Hot
5. Resistance
6. Electrolytics
7. By-Pass
8. Condensers
9. D'Arsonval Meter

MODEL CP

\$13.95
NET

Model TM—\$16.95 NET

3" square meter and continuous line voltage adjustment.

Deposit and the name of your jobber required on all direct orders.

MILLION RADIO AND TELEVISION LABORATORIES
577 N. UNION ST., CHICAGO, ILL.



STUDY RADIO Pay After Graduation

Entirely new, different Radio Servicing Course prepared with the help of 40 leading radio manufacturers. Planned to fit you immediately into a good pay radio job. We are so sure you will make real money after graduation that (except for one small down payment) we will let you pay later, out of your radio earnings. Write today for this "Earn Your Way" plan. It's Free.

RADIO TECHNICAL INSTITUTE
3727 W. Thirteenth St. Chicago, Ill.

Signal Mixer

(Continued from page 205)

panel and the box proper.

One side of the filament circuit and one side of the pilot light should be grounded. It is also desirable to keep the power lead as far away from the input circuits as possible.

The condenser C2 should be of the shielded type to prevent stray pick-up.

Parts List

- C1—Cornell Dubilier, type ED3250 dry electrolytic condenser, 25 mid., 25 volts
- C2—Cornell Dubilier, type DA4011, shielded paper condenser, 0.1 mid., 400 volts
- C3—2 Cornell Dubilier, type KR512, dry electrolytic condensers, 12 mid., each, 525 v. peak
- C4—Cornell Dubilier, type KR512, dry electrolytic condenser, 12 mid., 525 v. peak
- CH1—UTC, Detector plate choke, type CS44, 3 ma. max.
- R1—Yaxley volume control, type UC504, 3 megohms, or type UC506, 5 megohms
- R2—Yaxley volume control, type K12, 50,000 ohms
- R3—IRC carbon resistor, 50,000 ohms, 1 watt
- R4—IRC carbon resistor, 3000 ohms, 1 watt
- R5—IRC carbon resistor, 5 megohms, ½ watt
- R6—IRC carbon resistor, 30,000 ohms, 2 watt
- S1, S2—Yaxley, inductance switches, type 1215 L, 2 circuit, 5 point, shorting
- S3—sp.p.s.t. toggle switch
- T1—UTC input transformer, type CS103, double-button mike-to-grid



THE HIGH QUALITY TRANSFORMERS

For those who desire the finest broadcast quality and entire freedom from hum pick-up these more expensive U.T.C. transformers may be substituted

- T2—UTC output transformer, type CS106, single 56-to-line
- T3—UTC 913 power transformer, type PA913
- 1 Bud metal cabinet, type 1124; 12x7x6 inches
- 2 Bud chassis decks, type 525; 5½x4½ inches
- 2 Eby 8-prong wafer type sockets
- 4 Yaxley shielded plugs, type 75A
- 1 Yaxley 3-position dial plate, type 373
- 1 Yaxley 4-position dial plate, type 374
- 1 Yaxley red pilot light assembly, type 310R
- 2 Yaxley ¼ inch bar-type black knobs, type 366
- 2 Yaxley 2¼ inch bar-type black knobs, type 365
- 7 Yaxley infant jacks, single circuits, type A1
- 2 Crowe dial plates type 261
- 2 Sylvania tubes, type 5Z4 and 6N7

The "Masterpiece"

(Continued from page 213)

coils of high enough Q to give super selectivity, it is impossible to so broaden out a single i.f. amplifier as to permit high-fidelity "broadness" and still avoid a lopsided and sway-backed selectivity curve and undesirable gain variation. What is needed is not a single sequence, but separate and distinct i.f. amplifiers of permanently fixed transformers, one set for maximum selectivity and one set for maximum broadness. Two different types of i.f. transformers give the ideal amplifier, since neither need be compromised for the economy of individually variable i.f. transformers. In the new receiver, one set of low-Q transformers gives the extreme band width of 32 kc. for dependable and easy ultra-high-frequency reception or 16,000-cycle ultra-high-fidelity tone range. A second set, of a Q 50 percent higher than may be used in old-style variable selectivity system, gives the really phenomenal super-selectivity of 4 kc. bandwidth at the nose of the curve to 15 kc. width at 10,000 times resonant input. This is a selectivity ratio (admitted audio-tone band to interference rejection) of 3.75 to 1, or more than twice as good as heretofore available. Through the extraordinarily sharp, but flat-topped, band-pass selectivity possible with this new system, a new order of clear and intelligible tone quality is had at selectivity adequate to "clear up" the crowded 49-meter band—really effective 5-kc. selectivity. Through utilization of these different types of i.f. transformers, the two remaining selectivity choices necessary to fine reception are had—8-kc. band width for 4,000-cycle tone range and 10-kc. selectivity, and 12-kc. band-width, giving 6,000-cycle tone range for today's most generally useful chain network and high-fidelity reception.

As these four different selectivity choices are selected by the fidelity knob, gain is varied so that maximum sensitivity accompanies greatest selectivity (for extreme DX reception) while minimum gain is provided at minimum selectivity to avoid adjacent channel and noise interference in wide-

band, high-fidelity reception. This is further varied as the different wave-bands are selected, so that upon the ultra-high-frequency band maximum gain is had both in broad and sharp tuning. This ability to intelligently relate gain to selectivity is a feature inherent in this new "multi-band" selectivity system, as compared to conventionally, variable-selectivity systems in which the designer has little control over a usually unfavorable gain vs. selectivity-variation characteristic.

Following this new i.f. amplifier is a second tuned and amplified a.v.c. system, a duplicate of the first. This a.v.c. operates on the i.f. amplifier and holds volume amazingly constant for widely-varying signal strengths—volume is held constant to the practically undetectable variation of only 3 db. over a range of 300,000 to 1— or for all signals of strength between 10 microvolts and 3 volts. This second a.v.c. amplifier and rectifier actuates the 6G5 "magic eye," giving it sensitivity, and thus obtaining four different functions from this single 6B8 tube, used in the dominating design principle of getting maximum results with minimum complication.

The second detector of the set is the new infinite-impedance, linear detector. A 6J5 triode is used in a new circuit and replaces the diode detector. It is our belief that diodes cannot handle the 100 percent modulation encountered in all broadcast problems without introducing distortion. They are ordinarily good for only about 60 percent modulation. The new infinite-impedance second detector not only eliminates the selectivity impairing loading of the diode-feeding i.f. transformer, but handles the full 100 percent broadcast modulation range without distortion.

This detector contributes in great measure to the high-fidelity of the circuit up to 5 watts output, rising slowly to only 2½ percent total distortion at 34 watts output. This is in sharp contrast to the standard method of rating radio receiver distortion on the basis of the power output stage only. The figures given above are for the entire audio system of the new set, including every tube and circuit that might contribute distortion.

This tone quality results, not from complication, but from simplification of the audio system. Starting from the detector,

this tonal purity is maintained throughout the following circuits, each carefully designed to do its job in passing to the loud-speaker the same purity provided by the detector. A 6J7 tube acts as a built-in microphone or "phono" pick-up pre-amplifier and is selected by the fidelity knob as desired. This 6J7 feeds the main a.f. amplifier, consisting of a 6L7 volume-expander amplifier, with its two 6J5 expansion-control tubes, a 6J5 driver amplifier and two 6L6 Class A prime, beam-power tubes.

The volume expander is of a new type, completely eliminating overload blasting and distortion and providing controllable expansion to fit any broadcast or "phono" recording and to expand each program exactly as needed to make it duplicate the music played before the microphone.

Independent continuously-variable bass and treble tone controls allow tones to be accentuated, equalized or attenuated exactly as desired for each individual listener.

Of course, all r.f. and i.f. trimmers are permanent, non-varying, air-dielectric of the best types obtainable, r.f. and oscillator sockets are isolantite, wave-change switches are isolantite and gang-condenser insulation is special high-frequency mycalex. All this and more that space prohibits even mention of, make for superb long and short-wave performance, while a beat oscillator, which can be set for "single-signal" c.w. selectivity, gives code-reception ability and easy short-wave station finding.

The control panel is almost as complete as a broadcast station studio. One knob controls volume smoothly from a whisper to organ volume, automatically compensated to keep tone quality uniformly perfect at all volume levels. A fidelity knob gives choices of 4, 8, 12 and 32 kc. band-pass selectivity and "phono" or "microphone" operation. Another knob controls volume expansion as desired. Separate bass and treble tone knobs give complete tonal flexibility, and another selects between the five wave-bands. Tuning is through a 9-inch, full-vision, color-identified lance dial, the knife-edge pointer of which permits readings that eliminate usual parallax error. The tuning knob automatically selects 16:1 and 80:1 ratios and leaves nothing to be desired for easy and precise short-wave tuning. On the relogging, illuminated, band-spread dial seen through the window just above the tuning knob each wave-band is spread out to a length of over eight dial-feet—spreading usually crowded short-wave bands out over inches, not just a few degrees, or its 0-to-200 degree scale.

Television Range is Expanded

(Continued from page 203)

far away as Riverhead, L. I. The proximity of this Long Island town to the Empire State Building in New York, where the transmitting antenna is located, is indicated on the accompanying map together with locations of other towns within the service area of the sight-and-sound station.

Daily transmissions are being made to some seventy-five receivers in the homes of RCA and NBC engineers and executives. These are distributed in all locations marked off on the map.

The photo insert denotes the great height of the Empire State Tower at the left—the highest antenna point in New York City—which offers great advantages to the video station.

The "Tiny-Tot"

(Continued from page 215)

supply unit certainly helps in making a neat, compact assembly and its operation leaves nothing to be desired.

The r.f. tank circuit, with its associated leads to the grid and plate of the 45, is extremely important. It must be rigid and compact, but still not overcrowded. It is just a question of adopting a mechanical layout which will permit the desired electrical design. In this particular case the tuning condenser is mounted on a small panel of hard rubber, or other good high-frequency insulating material, which is fastened to the chassis with a bracket at the bottom. The r.f. choke, which connects to the center tap of the tank coil, is mounted securely on the back of this panel with a light, flexible lead to the coil. The latter is soldered directly to the tuning condenser terminals and placed so that it is a little more than its own diameter away from everything. The top is the grid end.

The tuning condenser is 20- mmfd., double-spaced, so that its capacity will be less affected by vibration and jolts. The two outside plates should be removed if good band-spread is desired. 10 mmfd. is all the tuning capacity that should be used at these frequencies.

If you don't already possess one; build, buy, or borrow a field-strength meter of some description. Do not depend on resonance indications on the milliammeter too much. This advice is particularly applicable to mobile transmitters. You are liable to find all kinds of resonance points on the milliammeter and it may be anything between the front and rear bumpers that is developing that nice, juicy current loop which you are trying to place on the antenna. (Next month, in the third article of this article of this series, a description of a complete, modern, car installation will be presented, including details of the wiring, antenna arrangement, etc. In this installation the "Tiny Tot" receiver is mounted in the glove compartment on the dash and the transmitter in the trunk. The installation is so arranged that everything is controlled from the receiving position—The Editors)

Parts List

- C1—Hammarlund, type MEX, Isolantite trimmer, 30 mmfd.
- C2—Hammarlund, type MC-20-MX, double-spaced variable, 20 mmfd.
- C3—Solar, .00025 mfd., mica
- C4—Mallory, type OT459 tubular condenser, .005 mfd., 800 v. a.c.
- C5—Mallory, type TP420 tubular, .25 mfd., 600 v.
- C6, C8—Mallory, type TN112 dual electrolytic, 5.5 mfd., 35 v.
- C7—Mallory, type TP415 tubular, .05 mfd., 600 v.
- C9—Solar, .00025 mfd., mica
- C10, C11—Mallory, type HS692, 8 mfd., 600 v.
- C12—Solar, .001 mfd., mica
- R1—10 ohm, 2 watt
- R2—1 ohm, 10 watt, adjustable
- R3—I. R. C., 50,000 ohms, 1 watt
- R4—I. R. C., 500 ohms, 1 watt
- R5—Yaxley, type Y250MP, ¼ meg. potentiometer
- R6—I. R. C., 3,000 ohms, ½ watt
- R7—I. R. C., 30,000 ohms, ½ watt
- R8—I. R. C., 5,000 ohm, ½ watt
- RFC—Grid leak form wound full with single layer of No. 28 d.s.c. wire
- CH1, CH2—U.T.C. chokes, 150 ma., 10 henry
- T1—R.F. tank coil, 6 turns No. 14 enam. wire, ¾-inch diam.
- T2—U.T.C. mike transformer, type CS-5
- 1—Mallory, type VP552 "Vibrapak" synchronous vibrator power supply, 300 v., 100 ma.
- 2—Yaxley, type A-2, midjet jacks
- 2—Eby, octal wafer sockets
- 1—Eby 5-prong plug connector (male and female)
- 1—Hammarlund, 4-prong Isolantite socket
- 1—National, type BM dial, scale 100-0-100
- 1—I.C.A., No. 3827 cabinet, 10 by 10 by 8 inches
- 1—I.C.A., No. 1561 chassis, 9½ by 7½ by 3 inches
- 2—Panel feed-through insulators
- 1—20 ampere fuse and holder



PERFECT FOR SOUND TRUCKS
Yet Can Be Used Anywhere

Operates on 110V. AC or 6 V. DC



Model MP-530 Has

- Plug-in Power Pack for either 6 Volt DC or 110 Volt AC operation.
- Hand Type Crystal Microphone
- Phonograph and High Fidelity Pickup Built into Amplifier
- Two Heavy Duty P.M. Speakers
- Mixes Microphone and Phonograph Tone Control also incorporated
- Economically Priced

Model MP-530 is designed to answer the problem of one sound system that will perform anywhere. This is the one system that all dealers should own. It will take care of any kind of rental demand, inside auditoriums, outside pavilions, sound trucks, roadside stands, camps, water fronts. Handles any size to approximately 5000 people—outdoors—twice this number indoors.

Everything you need is included—even a phonograph is built into the amplifier. Get into this fast-growing sound market today.

WEBSTER-CHICAGO INTER-OFFICE COMMUNICATING SYSTEMS
Plastic Cases • Choice of Colors



Model OCM

Made in 2-station and multiple-station systems with all variations. The Multiple System shown here is fast becoming the most popular. Dealers find that for a slight additional cost, customers can add more stations at a later date, should expansion make it desirable.

WEBSTER-CHICAGO
Section 0-6, 5622 Bloomingdale Ave., Chicago, Ill.

Please send me more information on:

- Model MP-530 All Purpose Sound System.
- Inter-office Communicating System.
- I am also interested in.....

Name.....
Address.....
City..... State.....

CENTRALAB VOLUME CONTROLS cannot be Equalled!



says **Mr. Owen O. Tressler**
of Elmira Heights, N. Y.



"Sir," says Old Man Centralab, "I am overcome with pride at this overwhelming vote of confidence. But

(ahem) I cannot feel but that my long years of smooth service to the radio industry merit this recognition."

Yes . . . Mr. Tressler is but one of the thousands of radio men from coast to coast who takes his hat off to OLD MAN CENTRALAB . . . and who is doing a better and more satisfactory service job because of the smooth performance of these world-famous volume controls.

Centralab

DIVISION OF GLOBE UNION, INC.
MILWAUKEE, WIS.

British Centralab, Ltd.
Canterbury Rd., Kilburn
London N. W. 6, England

French Centralab
Co., 118 Avenue
Ledru-Rollin, Paris
XI, France

You Can't Learn Code BY PRACTICE ALONE

THE CANDLER SYSTEM is the SURE Way to Code Skill!

You will succeed with the CANDLER system, because your natural sound consciousness is so developed that you send and receive code as easily as you talk and listen. Get the same training Candler gave World's Code Champion McElroy and thousands of code experts the world over! It's so easy when you practice RIGHT. Your progress will be amazing. Be a code expert. You can do it! All you need is CANDLER training.

FREE Book of Facts Write Today!

CANDLER SYSTEM CO.

Dept. RN-10
Asheville N. C., U. S. A.



Radio ENGINEERING College Electrical Standards

Maintaining the high academic standards of recognized engineering colleges, the School of Communication Engineering offers one and two year extension courses in Radio Engineering and Electrical Engineering. College credit ratings accepted by well-known engineering schools for advanced standing in Bachelor of Science courses. High School education prerequisite. Descriptive bulletin sent upon request.

NEWTON INSTITUTE OF APPLIED SCIENCE
Box 60, Jersey City, N. J.



THE TECHNICAL REVIEW

CONDUCTED BY THE TECHNICAL EDITOR

Notes on Amateur Radio Transmitter Design, compiled by James Millen. Published by James Millen, 1937. This is not a text book or handbook on transmitter design but a collection of articles describing equipment built for the author's station, W1HRX and a few other amateurs. Some of the material has already been published in QST. The book also contains complete technical descriptions of and instructions for the receivers and oscilloscope made by the National Company. The opening chapter deals with excitors, it shows several different ones, discusses the reasons for circuit choice, gives coil data, diagrams, views, etc. In the second chapter the final stages are treated and some attention is given to the proper L/C ratio. Thereafter follow some description of complete transmitters. Modulators are next in order then come power supplies. At W1HRX the high-voltage is obtained from a generator driven by an old automobile engine. Finally, there is a chapter on antennas, giving also a solution to the problem of how to make a mast.

Nicola Tesla, Memorandum book on the occasion of his 80th birthday, published by the Society for the Foundation of the Institute Nicola Tesla, Belgrade, 1936. During the year 1936, commemorations were held in Yugoslavia and other countries on the occasion of Nicola Tesla's 80th birthday. This book contains accounts of these commemorations, reprints of letters from famous men to Nicola Tesla and articles by several authorities describing Tesla's inventions. Several languages are used, including some of the Slavic languages; the greater part is in French and in German.

Review of the Proceedings of the Institute of Radio Engineers for July, 1937

Some Fundamental experiments With Wave Guides, by G. C. Southworth. Previous papers have set forth the theory and experimental results concerning the transmission of electromagnetic waves through hollow metal tubes, through pipes filled with insulation, and also through cylinders of dielectric material. This paper describes in considerable detail the methods by which the verifying experiments were made and adds data which it was not feasible to present previously.

Characteristics of the Ionosphere and their Application to Radio Transmission, by T. R. Gilliland, S. S. Kirby, N. Smith, and S. E. Reymier. Results of ionosphere measurements near Washington, D. C. made at normal incidence over the period May 1934, to December 1936, inclusive, are presented in graphical form as monthly averages for each hour of the day. The interpretation of

properties of the ionosphere in terms of radio transmission over medium and long distances is discussed.

A Multiple Unit Steerable Antenna for Short-Wave Reception, by H. T. Friis and C. B. Feldman. This paper discusses a receiving system employing sharp vertical-plane directivity, capable of being steered to meet the varying angles at which short radio waves arrive at a receiving location. The system consists of an end-on array of antennas, of fixed directivity, whose outputs are combined in phase for the desired angle. The antenna outputs are conducted over coaxial transmission lines to the receiving building where the phasing is accomplished by means of rotatable phase shifters operating at intermediate frequency.

Review of Contemporary Literature

THE following are reviews of articles appearing in recent issues of technical magazines; the name of the magazine and its date are given after the title of each article. Copies of these articles are not included under the "Free Booklets"—they are available from your bookdealer or direct from the publishers. Addresses of publishers will be furnished on request.

Supersonics, A Survey, by W. Mayberry, Electronics, July 1937. A review of past accomplishments in the generation and application of audio-frequencies above audibility.

Mutual Inductance Calculations, by Dale Pollack, Electronics, July 1937. Presenting a chart for determining the mutual inductance between two coaxial single-layer coils in terms of their winding pitches, dimensions and separation.

Consumer's Research Looks at Radio, Radio Engineering, July 1937. Presenting the criticisms of an unbiased, scientific organization on the products and policies of radio manufacturers.

Inductance or Capacity Tuning, by W. E. Bonham, Radio Engineering, July 1937. The article intends to show some of the more practicable effects which are produced in the circuit by obtaining resonance with either variable.

New Features in Broadcast Receiver Design, by B. R. Carson, K. A. Chittick, D. D. Cole, and S. V. Perry; RCA Review, July 1937. Describing new features of the modern receivers: automatic tuning, automatic frequency control circuits, band-spread circuits, improvements in cabinet acoustics.

Audio-Frequency Transformers, by E. J. Wrathall, The Wireless Engineer, July 1937. One of a series of articles on the theory and construction of audio transformers. The first article appeared in the June issue.

Battery Performance from the R.A.C.

Power Supply, by George Grammer, QST, August 1937. Showing several schemes of voltage regulation in power packs by means of two tubes. Regulation to within 1/4 of 1 percent is possible.

American Tentative Standard Acoustical Terminology, by H. A. Frederick; Journal of the Acoustical Society of America, July 1937. The new standards adopted by the A.S.A.

FREE BULLETINS

Valuable Booklet

The Sundt Engineering Company's folder on vibration study with the new neobeam oscilloscope is free to any engineer interested in industrial applications of vibration analysis. Send your request in on your letterhead to RADIO NEWS, 461 Eighth Avenue, New York City.

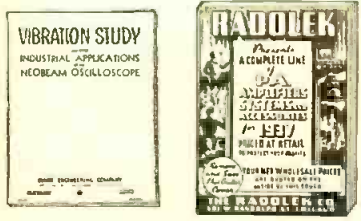

Public-Address Catalog

A new list price public-address catalog has been announced by the Radolek Company. This book is intended to assist the radio dealer and serviceman in selling P. A. equipment. A complete selection of reproducing systems ranging in size from 5 to 60 watts is given, as well as associated sound equipment. Copies are available to dealers and servicemen; send your request to RADIO NEWS, 461 Eighth Avenue, New York City.

Additional Profits for Servicemen

The Sprague Products Company recently offered to supply free copies of the National Radio Institute lesson of "How to Eliminate Man-Made Interference." This is a 30-page book with a great deal of instructive data on the subject, accompanied by many illustrations and drawings. Servicemen possessing this book and the latest Sprague catalog with its detail data on their special interference analyzer and noise filter will recognize the increasing importance of interference elimination as a profit-builder. To obtain a free copy send in your request to RADIO NEWS, 461 Eighth Avenue, New York City.

Large 14-Page Catalog

The latest Wright-DeCoster 14-page catalog features their bronze line of "Nokoil" speakers and also lists many new types of horns, speaker cabinets, and other accessories. For a free copy write to RADIO NEWS, 461 Eighth Avenue, New York City.

New Folder for Jobbers and Dealers

This is an 8-page circular describing the complete line of Kato gas-engine a.c. electric plants and also their new 32- and 110-volt d.c. power units. Various models are available to furnish from 300 to 10,000 watts. Send your request for a free copy to RADIO NEWS, 461 Eighth Avenue, New York City.

Replacement Catalog

The Solar catalog No. 1R lists a complete line of dry and wet electrolytic and paper replacement condensers, also a.c. motor starting replacement units. It is available on request from RADIO NEWS, 461 Eighth Avenue, New York City.

Sound Equipment Catalog

The Lifetime Corporation's new catalog listing their complete line of p.a. equipment and accessories is free to all our readers. To obtain a copy, address RADIO NEWS, 461 Eighth Avenue, New York City.

Data on New Peri-Dynamic Reproducers

The Jensen Radio Mfg. Co. has kindly offered to supply a copy of their guide book on "Peri-Dynamic" speakers free to RADIO NEWS readers. The folder covers all phases of use, operation, and installation of these new speakers. Address requests to RADIO NEWS, 461 Eighth Avenue, New York City.

RADIO NEWS Booklet Offers Repeated

FOR the benefit of our readers, we are repeating a list of valuable, FREE technical booklets and manufacturers' catalog offers, which were described in detail in the May, June, July, August and September, 1937 issues. The majority of these booklets are still available to all readers. Simply ask for them by their code designations and send your request to RADIO NEWS, 461 Eighth Avenue, New York, N. Y. The literature marked with an asterisk is available only to bonafide servicemen, dealers, and engineers. In applying for these folders it is necessary to send in your request on your card or letterhead. If you are an amateur give call letters. The list follows:

- My1—Service booklet. Readrite Meter Works.
- My2—Folder on small motor-driven "Handee" tool. Chicago Wheel & Mfg. Co.
- My3—Resistor catalog. International Resistance Co.
- My5—D. Van Nostrand Company's general book catalog.
- My6—Volume control guide. Central Radio Laboratory.
- My8—Condenser catalog. Solar Manufacturing Company.
- Je1—Circulars on power equipment. Pioneer Gen-E-Motor Corp.
- Je2—Parts Catalog. Allied Radio Corp.
- Je3—Radio Receiver Catalog. Modell's*
- Je4—Catalog on P. A. equipment. United Sound Engineering Co.*
- Je5—Tube Chart Arcturus Radio Tube Co.*
- Jy1—Instrument Topics. A new folder published periodically by Clough-Brengle Co.*
- Jy2—Instrument Catalog. Triplett Electrical Instrument Co.
- Jy3—Catalog on industrial capacitor replacements for refrigerators, etc. Aerovox Corp.*
- Jy4—Sound Equipment Guide. Wholesale Radio Service Co.
- Jy5—Parts Catalog. Radolek Co.*
- Jy6—Latest Catalog on accessories. Radio Corp. of America.*
- At1—Broadsheet on Super-Pro. Hammarlund Mfg. Co.
- At2—Catalog on Transmitting Equipment. Wholesale Radio Service Co., Inc.*
- At3—Folder on Western Electric G33, a dynamic microphone.
- At4—Tube Folder. Weston Electrical Instrument Corp.*
- At5—P. A. Catalog. Webster Co.
- At6—Catalog on Electrical Wiring Accessories. Harvey Hubbell Co.*
- S1—Accessory Folder. American Phenolic Corp.
- S2—Transformer Catalog. Kenyon Transformer Co.
- S3—P.A. Equipment and Parts Catalog. Inter-World Trade Corp.

QRD

(Continued from page 233)

And last, but not least, we wish to congratulate the heroic work of Radiop John Gallie of the burned and founded SS Sandgate Castle whose crew was rescued by the President Pierce. Captain Bergen of the Sandgate Castle commended Gallie when he stated: "He stayed at his instruments sending out the SOS signals until the last moment when I hauled him out of the radio shack and we both left the ship together." Just another instance of that tradition which has been upheld by radiops all over the world. So with a cheerio and ge . . . 73 . . . GY.

The Best "BUYS" Are Made for Cash!*



* By "CASH" we mean your jobber's regular terms.

During the years when "sinking-or-swimming" was an everyday problem, a lot of business men, pressed for cash, got into "no investment" merchandise deals. One by one, most of them have fought their way back to sound business principles. And *only* by buying the *finest quality* merchandise at *lowest possible* cash prices have they been able to prosper.

In the tube field, RAYTHEON offers the highest quality tube made—at cash* prices that save money for dealers every time they buy RAYTHEONS! That is why RAYTHEON business has more than tripled in the last two years . . . why RAYTHEON dealers are prosperous business men! Ask your RAYTHEON jobber.



- 445 LAKE SHORE DRIVE, CHICAGO, ILL.
- 555 HOWARD STREET, SAN FRANCISCO, CAL.
- 420 LEXINGTON AVENUE, NEW YORK, N. Y.
- 55 CHAPEL STREET, NEWTON, MASS.
- 415 PEACHTREE STREET, N. E., ATLANTA, GA.

The "Ham" Shack

(Continued from page 207)



.. For Smooth Sailing!

With Hammarlund XP-53 coils and coil forms in your receiver or transmitter, you can always depend on "smooth sailing" performance for superior results! The special low-loss natural colored XP-53 dielectric has an unusually low power factor, is rugged and extremely durable. Available in blank (4, 5 and 6 prongs) or wound style (14 coils—4 or 6 prongs—10 to 560 meters). New "37" catalog with more data and illustrations now available. Write Department RN-10 today for your free copy!

HAMMARLUND MFG. CO., INC. RN-10
424-438 West 33rd St., N. Y. City

Please send me "37" catalog.

Name

Address

City

State



HAMMARLUND

NEW 1938 HETRO RADIO

BUY DIRECT—SAVE 52%
14 TUBE DELUXE
ALL WAVE

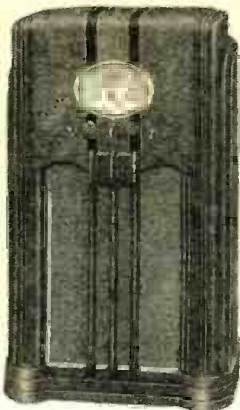

- Beam Power Push Pull
- Dual Channel Audio
- Electric Tuning Eye
- 15" Dynamic Speaker
- Manual Base Amplification
- R F Pre-Amplification
- Available with or without cabinet

14 Other Models from 5 Tubes Up

Have you heard the NEW HETRO SOUND SYSTEMS? Write for descriptive circular.

HETRO ELECTRICAL INDUSTRIES, Inc.
4611 Ravenswood Ave., Chicago, Ill., U. S. A.

Send me FREE circular giving complete description NEW 1938 14 Tube Deluxe HETRO, 14 other Hetro models, and HETRO SOUND SYSTEMS. Also quote your DIRECT FROM THE FACTORY PRICES with savings of 52%, and liberal 10 DAY FREE TRIAL OFFER in U. S. A. only.

Name

Address

10 DAYS FREE TRIAL

FOREIGN DISTRIBUTORS—The extensive HETRO line, long manufactured for the Export Trade, offers real money-making opportunities. WRITE or CABLE for Territories still available.

or touched to the metal case of the crystal. It will glow if the stage is oscillating.

Incidentally it will be found that the oscillator control is not extremely critical in adjustment, particularly when crystals in the 40, 80 and 160-meter bands are used. It is more critical when 20-meter crystals are used. If several crystals are available for one band, by setting the oscillator control for resonance of the lowest-frequency crystal to be used, it will not be necessary to make readjustment when the crystal is changed. It will oscillate satisfactorily with any crystal higher in frequency up to about 150 kilocycles and provide sufficient excitation for the 802 buffer. The 802 is a convenient tube to use because of its low excitation requirements. Three or four milliamperes of rectified grid current with normal bias is ample. The power required is .5 watt.

With the oscillator adjusted, the plate power should be turned off and the buffer tank coil inserted in its socket. The 0-200 milliamperemeter should be plugged into the 802 plate jack and the 0-25 meter placed in the grid circuit of the final amplifier. Then the plate voltage should be turned on and the buffer tank condenser adjusted until the maximum grid current is caused to flow in the grid circuit of the 807's. This should be between 5 and 8 milliamperes. If it is too high, the plate voltage on the 802 should be reduced by adjusting the voltage-divided tap for this tube until the desired amount of excitation is obtained. The plate current (and screens) should be about 50 milliamperes.

Next the final amplifier should be neutralized. This may be done with either a neon bulb or a galvanometer. The latter is best, but the former will serve if a galvanometer is not available. If a neon bulb is used, it should be touched to the plate end of the final amplifier tank coil. Then the plate tank-condenser should be rotated slowly. Unless the amplifier is accidentally neutralized, it will glow when the plate tank condenser passes through resonance. With the neon tube still glowing, the neutralizing condensers should be adjusted until there is no indication of radio frequency in the plate circuit of the 807's without plate voltage applied.

When this condition is noted the stage is neutralized. The procedure is practically the same when a galvanometer is used. A small loop connected across the two terminals of the meter is coupled at some distance to the plate tank-coil. It should read when resonance is reached. The neutralizing condenser then is adjusted until the meter stops indicating radio frequency in the plate circuit.

As a means of checking whether the amplifier is properly neutralized or not, the tuning condenser should be rotated slowly backward and forward. The grid current on the 807's should remain absolutely stable. If the amplifier is not neutralized it will dip when resonance is passed. This grid current dip also may be used for neutralizing if neither a neon bulb nor galvanometer is available.

Next the plate voltage should be applied to the 807's. This may be done by either short-circuiting the modulation transformer terminals or connecting in the modulator. The former is preferable as it avoids the danger of overloading the modulation transformer secondary, thus the possibility of burning it out. The plate condenser should be tuned to resonance as quickly as possible. This is indicated by a decided dip in the plate current. It should fall to

between 30 and 50 milliamperes. This is the current for both the plate and screen of the 807's.

The transmitter now is ready to couple to an antenna. Almost any type of coupling may be used. Perhaps the simplest is to use some form of link coupling or low-impedance line. If the antenna to be used has a twisted-pair feeder, the coupling problem is simple. All that is necessary is one or two turns of insulated wire around the center of the plate tank coil. The number of turns will be determined by the manner in which the antenna loads up the antenna and may be found only by experiment. The coupling should increase the resonant plate-screen current to about 160 to 190 milliamperes.

If other types of antennas are used, different coupling methods may be tried. If a Zeppelin type of antenna is used, a duplicate tank circuit should be constructed and set outside the transmitter. Either series or parallel tuning should be used. The two coils should be connected together by means of a link circuit.

When all of the circuits are properly adjusted, the transmitter is ready for a test on the air. In the tests at the writer's station the transmitter was put on 20 meters for an initial test. Using a half-wave doublet antenna, with twisted-pair feeders, the unit loaded up nicely with 2 turns of coupling around the center of the tank coil and connected directly to the antenna feeders. The plate-screen was 180 milliamperes, 20 mills. of which were screen current on the 807's. Tests were made with a local station at first. The signal was reported as loud as the regular 500-watt transmitter used at W2MW, and the quality was excellent. While no extreme DX was worked during the short period of tests, several ninth, fourth and fifth district stations were worked through the heavy early-evening QRM. The reports ranged from QSA4-R7 to QSA5-R9 plus! The small transmitter was found to be equally as effective as the higher-powered unit. A comparison was made between the big transmitter and small one with a fourth district station. The operator there reported the two signals of about the same intensity.

Next the transmitter was tuned to 10 meters. A 40-meter crystal was used and the 6C5-802 unit was used as a quadrupler. The grid current on the final amplifier was 6 milliamperes. The antenna used was a half-wave vertical, the bottom end of which was one wavelength above ground. Excellent output was obtained, although at the time the tests were made no distant stations were coming through. However, several local stations were worked and R9 reports were received.

To operate this transmitter on 40 meters it is, of course, necessary to provide a means of keying. This was done by connecting in a 22½-volt battery in the grid circuit of the 807's (in series with the grid resistor) and key in the cathode circuit of the 802 by connecting a key in series with the cathode resistor and ground. This was tried, but the transmitter was not actually put on the air because of the lack of an adequate antenna for this band at the time of the tests. It keyed beautifully and provided ample output that, when used with a good antenna, should put out an effective signal.

Next the transmitter was tested on the 75-meter phone band. Despite the comparatively low power, excellent reports were obtained. Five contacts were made within a half hour and all reports were QSA5-R8 to R9. No difficulty was experienced with QRM, although this band is particularly noted for this condition. However, it must be pointed out that the tests were made during the daytime when operation on this band was far from peak.

Summing up the results of these tests, the small transmitter proved itself an excellent all-band unit on small power. On the higher frequencies it proved a good competitor for the 500-watt transmitter used at W2MW. On the lower-frequency bands it put out a signal that could compete with the normal QRM with more effectiveness than was expected. The transmitter also was tested on 160 meters, not at the writer's station, but at a nearby station that was equipped with an adequate antenna. Here it put out a good signal and the operator who made the test reported local communication was excellent and more than six "out-of-the-district" stations were worked within a short time.

U-Beam Aerial

(Continued from page 207)

elliptical field in the favored direction while holding down back radiation.

All of the elements in this antenna are mounted on two light wooden rectangular frames and when used in a fixed direction may be mounted by four ropes.

The photograph above has been made large enough so that experimenters wishing to try it can make actual measurements for construction. The upright radiators and reflectors are eight feet long.

Amateur X'mitter

(Continued from page 211)

wiring diagram, one receptacle serves for using the exciter unit to drive the grid of the RK-20 at the crystal frequency; the other when it is desired to use the unit as both oscillator and doubler. The 6A6 is a twin triode tube. One section is used as the oscillator and the other as the doubler.

Controls on the front panel of the transmitter are conveniently arranged. At the left is the amplifier tank condenser and, at the right, a novel combination filament-plate-meter switch that has four positions. In the center is a dual meter calibrated to read the plate current on the final amplifier, the grid current on the amplifier and the cathode current on the 6A6. In the center of the front panel is an opening which permits watching the RK-20 while the transmitter is in operation.

The four positions of the combination switch are: 1, the completely "off" position; 2 turns on the filaments of all tubes, the plate voltage for the 6A6 and switches in a shunt that causes the meter to read cathode current; 3 switches the low-range scale into the grid circuit of the RK-20 and reads the rectified grid current, and 4 turns on the plate power for the final amplifier. In this latter position the 0-25 milliamper meter remains connected in the grid circuit of the amplifier.

Coils for the final amplifier are wound on ceramic coil forms equipped with six-prong bases. These are plugged into a standard socket and provide both plate and antenna connections as shown in Figure 3.

The exciter stage units are of three types designated as "C," "CD" and "D." Each type stage has its own correct cathode resistor and by-pass condenser to provide the correct bias and automatic protection against excessive plate current. The type "C" has provision for plugging the proper crystal into the grid circuit of the oscillator tube externally. Here only a single section of the 6A6 is used as the oscillator tube.

In the "CD" units, Figure 2, one section

of the 6A6 is used as a crystal oscillator as in the type "C" stage and the second triode section as a doubler tuned to twice the frequency of the oscillator.

The type "D" stage is used only as a frequency doubler. The triode sections of the 6A6 are connected in parallel, thus providing greater output. With this type unit it is necessary to use a type "C" unit in the oscillator circuit. The oscillator units are connected in one receptacle (position 1 in Figure 1) and the buffer and oscillator-

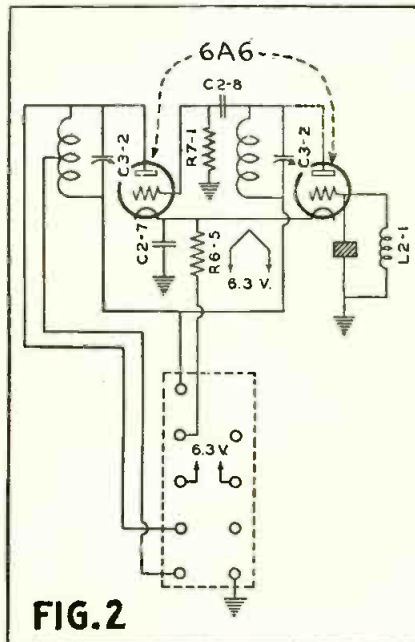

FIG. 2
buffer units in the other (position 2).
Next month an article will be presented

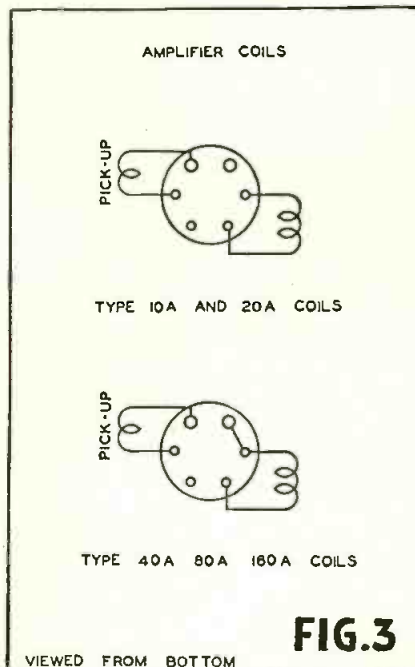

FIG. 3
describing operating tests of this transmitter at the author's station.

Reduced Rates

New York, N. Y.—The Postal Telegraph Co. reduced the rates for telegrams in which figures are used. Under the new rate, the charge for five numerals will be the same as for one word; while formerly each numeral counted as a word. A decimal point, fraction bar or dash will also be counted as a figure. This rate also applies where number combinations are used as code.

**Learn
RADIO
in
12 WEEKS**

**BY ACTUAL SHOP WORK
ON REAL EQUIPMENT**

SEND TODAY FOR DETAILS OF MY



"Pay-Tuition-After-Graduation" Plan

Prepare now for big opportunities in the world's most fascinating profession. Get your training in the Coyne Shops in a practical way and be prepared to take a real job and cash in quickly... I offer you the opportunity to finance your training. Send now for details of my "Pay-Tuition-After-Graduation" Plan and Big FREE illustrated book with all the facts about Coyne training. Mail Coupon today for details.

REAL OPPORTUNITIES For the Radio Trained Man

Prepare for a job as Designer, Inspector and Tester — as Radio Salesman and in Service and Installation — as Operator or Manager of a Broadcasting Station — as Wireless Operator on a Ship or Airplane — as a Talking Picture or Sound Technician — HUNDREDS of Opportunities for fascinating, WELL PAID JOBS!

12 WEEKS' SHOP TRAINING

No Experience or Advanced Education Needed
We don't teach by book study. You get your training at Coyne in Chicago by ACTUAL WORK on a great outlay of Radio, Broadcasting, Television, Talking Picture and Code equipment. And because we cut out useless theory, you get a practical training in 12 weeks. That's why you don't need advanced education or previous experience.

TALKING PICTURES — TELEVISION

Talking Pictures and address systems offer great opportunities to trained men. Television is the great new branch of Radio now developing very rapidly. Be ready for your chance in Television. At Coyne you are trained on real Talking Picture and Television equipment.

ELECTRIC REFRIGERATION AND AIR CONDITIONING Included at NO EXTRA COST

So our graduates may have an all around training which increases their earning capacity, we are including, for a short time a new course in Electric Refrigeration and Air Conditioning. Here is your chance to get a practical training in this great new field at no extra cost.

Many Earn While Learning

WHEN YOU ENROLL AT COYNE YOU GET A LIFE SCHOLARSHIP. You get Free Employment Service for Life after graduation. If you need part time work to help pay living expenses, I may be able to help you if you will write and tell me your problems. Coyne is 36 years old. Coyne Training is tested—you can find out everything about our course and "Pay-Tuition-After-Graduation" Plan. JUST MAIL Coupon for My BIG FREE RADIO BOOK. Coyne Electrical and Radio School, 500 S. Paulina Street, 77-3K, Chicago, Ill. *H. C. Lewis*

SEND NOW FOR FULL DETAILS!

H. C. LEWIS, President.
Coyne Electrical & Radio School,
500 S. Paulina St., Dept. 77-3K, Chicago, Ill.
Dear Mr. Lewis: Send me your big Free Radio Book and all details of your Special Tuition Offer — and about your "Pay-Tuition-After-Graduation" Plan.

Name..... Age.....
Address.....
City..... State.....

the AMPERITE VELOCITY with NEW DESK STAND

Ideal for desk, pulpit, footlights, banquets. Leaf spring suspension acts as shock absorber **STAND ONLY** . . . LIST \$4.00 **NAME PLATE** with call letters . . . LIST \$2.00

MICROPHONES: Model RBHa (High Imped.) or RBMa (200 ohms) with cable connector & switch . . . LIST \$42.00 Models RBSn, RSHn. with switch only . . . LIST \$32.00

NEW "HAM MIKE"

No Peaks! No Splashing! Real Broadcast Quality! RF Choke Circuit included in microphone. Output.-68 db. Operates directly into grid. **MODEL HAM** (High Imped.) or **MODEL HAL** (200 ohms) . . . Gunmetal. LIST \$22.00. Chrome LIST \$23.00. Price includes Ham Desk Stand. Call Letters, and 6 feet of cable.

MODEL RAL \$22.00 LIST

A popular Amperite Velocity of very high excellence. Used for both speech and music. No peaks. Flat response over audible range. Output.-68 db. Triple shielded. Shock absorber, swivel bracket. **MODEL RAL** (200 ohms); or **MODEL RAH** (2000 ohms) high impedance . . .

FREE: Window Decal & Window Display

AMPERITE Co. 361 BROADWAY, N. Y.

AMPERITE Velocity **MICROPHONE**

TALK-BAK*



Model TBU 1700
Size—6½" diameter, 3" high

Lasting Wear, Perfect Operation, Attractive Appearance

The most complete, best looking Talk-Bak* Unit manufactured. A steel cabinet with a taupe suede finish so soft as to protect the finest furniture.

FREE New Technical and Sales Pamphlet

gives complete information regarding all known inter-communication systems. Method of connecting different Talk-Bak* Units and full detail information on what they will accomplish. Write for it and be sure to include your distributors' name.

Wright-DeCoster Distributors are always anxious to cooperate.

WRIGHT-DeCOSTER, Inc.

2255 University Avenue, St. Paul, Minn.
Export Dept.: M. Simons & Son Co., New York
Cable Address: "Simonrice"

Canadian Representatives:
Wm. F. Kelly Co., 1207 Bay St., Toronto, Ontario
Taylor & Pearson, Ltd., Edmonton, Alberta
Copyrighted

WHAT'S NEW IN RADIO

WILLIAM C. DORF

(Continued from page 201)

540 to 7000 kilocycles. It employs a 6½ inch speaker and is designed to provide 5 watts output power.

Something New in Call Systems

The United Sound Engineering Company's personal call-phone features neat appearance, compact design, easy operation and installation. This latest inter-office communicating system is equipped



for both headphone and loudspeaker use. When the ear phone is lifted from its rest the loud-speaker is automatically disconnected, bringing the other party's conversation confidentially through the earphone. When using the headphone it is not necessary to work the lever between "Talk" and "Listen."

Specialists in Electrical Wiring Accessories

The accompanying illustration shows a new Harvey Hubbell convenient duplex power and radio wall outlet with plate, No. 4504 and special radio plug No. 4505. The radio receptacle is designed to prevent

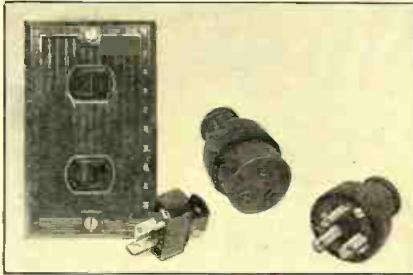

interchange of the radio and power caps. The unit is furnished with a shield separating radio and power circuits. The second item is the latest 3-wire, 10a 250v. indestructible rubber cord connectors with self aligning phosphor bronze contact springs. The handle section of the connector rolls back and is easily detached for wiring.

Improved Resistors

The accompanying cut-away illustration shows the features of the new improved type resistor developed by the Ohmite Manufacturing Co. No. 1 shows the evenness of windings; this feature prevents "hot spots" and resulting failures and makes for long and reliable service on the job. At No. 2, the vitreous enamel covering is shown.

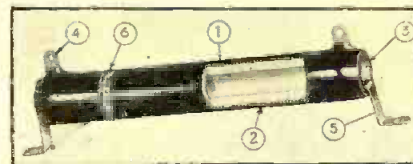

These resistors are solenoid wound over a porcelain core (No. 3) and the copper terminals (No. 4) are tin-dipped to make for ease in soldering to connecting wires. The resistors are equipped with mounting brackets (No. 5), specially designed to hold the units in place as well as to permit ease of mounting and demounting. Each resistor is identified by an aluminum band (No. 6) upon which the resistance of the unit is plainly stamped.

30-Watt, High-Gain Amplifier

Here is a compact 4-stage amplifier engineered by the Radolek Company, to provide a gain of 130 db. so as to permit operation with full output from any standard high-impedance microphone such as a crystal, velocity, etc. Input connection arrangements are provided for phonograph and radio input which can be mixed with the mike signal. The tubes employed con-

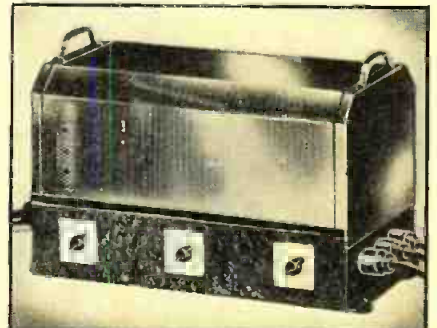

sist of one 6F5G input amplifier, one 79 electronic mixer, one 76 driver, two 6L6G's in push-pull output and one 83 rectifier.

New General Purpose Triode for the Amateur

The new Taylor type T-20 is a general purpose triode, designed for use as a doubler, buffer, or as a class "B" modulator. Its operating characteristics for r.f. and a.f. services are given in the Transmitting Tube Chart elsewhere in this issue. The manufacturer lists the following advantages that this tube offers over others in its size class: The interelectrode capacities are lower, making possible satisfactory operation on frequencies as high as 60



megacycles. The amplification factor is higher, making less grid drive necessary and simplifying the bias requirements, and bringing the plate lead out of the top of the bulb greatly reduces the possibilities of voltage breakdowns.

Latest High-Fidelity Speaker

This is a special console cabinet loudspeaker, acoustically treated to provide a substantially uniform frequency response from 60 to 10,000 cycles. It is a product of the RCA Commercial Sound Section and they point out that it is particularly applicable for use as a high-fidelity monitoring



speaker for broadcasting stations, for use in music rooms, and wherever life-like reproduction is a factor of prime importance.

The console is completely enclosed and measures 33 1/3 inches high by 28 1/4 inches wide by 16 1/2 inches deep. The speaker unit is of the double voice coil electro-dynamic type, and measures 8 by 8 inches by 7 inches deep. The power handling capacity of the loudspeaker is 10 watts and it has a voice coil impedance of 15 ohms.

Convenient Adjustable Line Transformer for Servicemen

This Halldorson "vari-volt" transformer is adjustable from 0 to 256 volts in two-



volt steps or from 0 to 128 volts in one-volt steps. Power output 250 watts maximum. Servicemen and experimenters will appreciate this new power unit. It has excellent application for the work bench for supplying various ranges of voltages needed for testing radio sets, experimental work, etc., also for compensating variations in line voltage.

6-Tube All-Purpose Radio

The Galvin "Companion" combination 6-volt battery and 110-volt plug-in portable set can be used as a trailer radio, on outings or in the home as an auxiliary set. Merely flicking a switch effects change- (Turn to page 252)

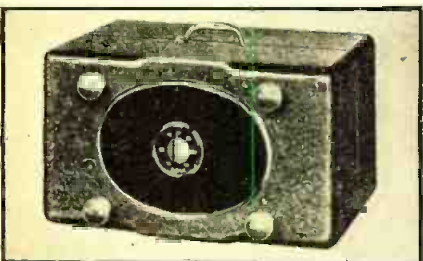

Designed to Withstand
**ROUGH
FIELD
SERVICING**
Readrite
RANGER



PRECISION
BUILT
\$19.50

MODEL 740

FOR THAT DUPLICATE SET OF SERVICING INSTRUMENTS ADVOCATED BY LEADING SERVICEMEN

Model 740 Volt-Ohm-Milliammeter has 3" Square Triplett Precision Instrument. Scale readings: 10-50-250-500-1000 A.C. and D.C. Volts at 1000 Ohms per Volt (D.C. Accuracy 2%; A.C. 5%); 1-10-50-250 D.C. M.A.; 0-300 low ohms; High Ohms to 250,000 at 1 1/2 Volts. (Rheostat adjustment for 13 1/2 volts for Ohm readings to 2 1/2 Megohms.) Batteries may be added permitting such readings in 250,000 ohm steps. Low Ohms to 1/2 Ohm with 25 Ohms in center of scale. Backup circuit used. Current draw is only 1 M.A.

**VOLT-OHM-MILLIAMMETER
NO EXTRA CASES TO BUY**

Readrite Meter Works
1015 College Dr., Bluffton, Ohio

Please send me more information on Model 740.

I am also interested in.....

Name.....

Address.....

City..... State.....

TRIAD

**Triple-Checked Radio Tubes
IMPROVE YOUR RECEPTION**

Used by Leading Set Manufacturers
and Preferred by Expert Servicemen

A Profitable Line to Handle

—Write for Particulars—

TRIAD MANUFACTURING CO., Inc.
PAWTUCKET RHODE ISLAND

THE QUALITY NAME IN RADIO TUBES

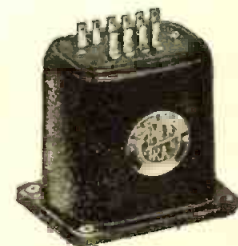

STAND-BY

FOR years the reliability of AmerTran Transformers has been a by-word among amateurs, as well as experienced engineers. Highest quality materials and the highest order of craftsmanship result in remarkably clear, natural amplification under all circumstances.

★ Frequency characteristics are exceptionally uniform; filter types give full inductance with rated d.c. flowing; power units have better than 10% regulation. Consult Bulletin 1002 for complete details. Write—



AMERICAN TRANSFORMER CO.
178 Emmet Street Newark, N. J.



FREE BOOK of Opportunity
Instructive facts about
**TELEVISION
RADIO
SOUND RECORDING**

Complete, practical instruction. Earn room and board while learning. Coach railroad fare allowed to Los Angeles.

NATIONAL SCHOOLS

MAIL COUPON FREE BOOK

National Schools, Dept. 10-RN,
4000 So. Figueroa St., Los Angeles, Calif.

NAME..... AGE.....

ADDRESS.....

CITY..... STATE.....

BUILT FOR PERFORMANCE



TRANSFORMERS FOR EVERY APPLICATION

LABORATORY BROADCAST

*Portable Broadcast
General Purpose
Replacement*

Separate Catalogs Describing the Various Kenyon Lines of Audio and Power Units Are Obtainable from Your Local Dealer

KENYON TRANSFORMER CO., INC.
840 Barry St. New York, N. Y.
Export Dept. 25 Warren St., New York, N. Y.

The "Philharmonic"

(Continued from page 220)

other hand if it is desired to emphasize the majesty of the treadle-notes of the organ, the bass control provides a means for doing so. The "Hi Fidelity" or treble control provides similarly wide flexibility in adjusting the response in the upper registers. This was found useful in compensating for acoustic defects in the ordinary room; also in reducing external noise when tuning in distant stations.

The Scott loudspeaker, in keeping with other portions of the receiver which contribute to its high-fidelity reproduction, is fully capable of effectively reproducing a considerably wider musical range than that transmitted by even the finest regular broadcast stations. A striking feature is the purity of tone in all ranges. The low rumbling notes of the organ, for instance, are reproduced with the same breath-taking, buffeting sensation experienced when one is present in an auditorium. At the other extreme the piercing notes in the highest organ register are heard with equal naturalness. There is no "paper rasp" on the low notes; no "escaping steam" effect on the high notes. As a result, the listener is not continuously reminded that he is listening to electrical reproduction. With lights dimmed it requires no effort at all to imagine oneself actually present in the auditorium where a fine program originates.

The matter of sensitivity could be dismissed with the statement that the *usable* sensitivity exceeded all requirements for both broadcast and short-wave reception. The only limiting factor was such local noise as existed in the test locations; and the interfering effect of this was considerably reduced by the Scott antenna and built-in, noise-reducing coupling system. The accompanying curves, Figure 1, show the Scott measurements of sensitivity for the five most popular ranges to be well below one microvolt, at a signal-to-noise ratio of 1 to 1. In view of the fact that very few locations have local noise lower than 5 microvolts it is at once obvious why the receiver provides greater sensitivity than can be used. This was clearly demonstrated in the tests and many signals were heard well that were spoiled by noise, when an attempt was made to tune them in on another receiver.

When the "Selectivity-Hi Fidelity" control was set for maximum selectivity it was found possible to tune in station 10 kc. either side of every local, at times when the locals were confining themselves to 100 percent modulation. Tuning in WLW, Cincinnati, with absolutely no interference from the local WOR was no trick at all for this receiver; but to tune in WWL, New Orleans, with no QRM from WABC, is an achievement when it can be done quite regularly as proved to be the case in these tests. When in this maximum selectivity position the higher frequencies are greatly attenuated, thus reducing noise to a degree highly favorable for DX signals.

On the short waves, stations operating 10 kc. apart were completely separated in almost every case. The few exceptions being apparently where one or the other was incorrectly operated, or where one was fading down practically to inaudibility.

In general, short-wave reception was found to be more consistent with this receiver than is usual. German, English, Czechoslovakian, Russian, Australian, Italian, Dutch, French and South American stations were received, frequently with stability and clarity actually equivalent to "local" broadcast stations. More than once it was necessary to wait for a Russian

SEC. DIV.	KILOCYCLES	LOCATION
78	DJR 15,140	GERMANY
77	W2KAD 15,130	SCHENECTADY
76	OSP 15,310	ENGLAND
75	DJQ 15,280	GERMANY
74	W2AE 15,270	NEW YORK
73	TPA2 15,245	FRANCE
72	OLSRA 15,230	CZECHOSLOVAKIA
72	PCZ 15,220	HOLLAND
71	W2BK 15,210	PITTSBURGH
71	DJB 15,200	GERMANY
70	OSO 15,180	ENGLAND
69		
68	G5F 15,140	ENGLAND
67		
66	RKI 15,090	RUSSIA

station, for instance, broadcasting a program in English, to sign before a visitor would be convinced that such excellent reception could be obtained from such a distance.

Tuning, even at frequencies as high as 25 megacycles, was as easy as tuning most receivers in the broadcast range. The "second" hand in the center of the large dial proved definitely advantageous in logging stations. This hand moves over a complete circle divided into 100 parts. The way stations spread out is shown in Figure 2 which covers a part of the 19-meter band. Even here each division of the second scale represents only about 20 kilocycles. It is a noteworthy fact that these stations were logged at the dial settings shown the day the receiver was set up—and throughout the 6-week test period.

The automatic gain control system provided such complete control that in tuning through the entire broadcast band, for instance, distant stations were distinguishable from locals only by the fact that noise accompanied the very distant ones, due to the automatic increase in sensitivity as weak stations were tuned in. It is only when tuning for DX signals that any noise need be encountered. In regular home operation the manual gain control is normally retarded (with no station tuned in) to a point where no noise is heard, and left that way. Then as the receiver is tuned nothing is heard except broadcast signals that are above the local noise level.

Another feature of the receiver lies in its use in the reproduction of phonograph records. As in radio reproduction, its musical range far exceeds that of recorded programs. The Scott pick-up unit which is especially designed to provide wide frequency response and minimum wear on the records, likewise does an excellent job.

The needle scratch suppressor marks a very definite advance in reproduction from records as it minimizes the one objection that has always existed in phonograph reproduction—namely, surface noise, or scratch. In the RADIO NEWS tests the effectiveness of this new system was carefully checked and is enthusiastically approved. It removes the constant reminder, when one is listening to a phonograph record, that it is a mechanical reproduction and for that reason adds tremendously to the enjoyment of recordings.

This, then, is the story of the study and tests of the Scott "Philharmonic". A receiver which provides outstanding features galore. Designed primarily for the enthusiast who demands radio reception par excellence, it accomplishes this aim in a manner which even a few months ago would have been considered incredible.

Correction on "Movie Sound"

Due to a typographical error, the output of a photocell was given as 50 db in Part 2 of this series. This should read *minus* 50 db (zero level, 6 m.w.)

**"PINCO"
DYNAMOTORS
CONVERTERS
GEN-E-MOTORS**

Radio engineers have learned from experience that Pioneer Gen-E-Motor Corporation's dynamotors, gen-e-motors and converters provide the most word in dependable power supply units for air craft, police, public and auto radios and public address systems. They are available in a wide range of capacities for every requirement. Designed and constructed to give maximum life and service. Light weight and compact. For complete information write

PIONEER GEN-E-MOTOR CORPORATION
Manufacturer of "PINCO" Products
Dept. No. R-3J
466 West Superior St.
Chicago, Ill.

X'Tal Control Transmitter

(Continued from page 208)

from the only knob on the control unit. The 6 volts for operating the relays is obtained from transformer T18 in the r.f. control unit.

R5 and R6 comprise the aforementioned bleeder for the bias supply. Each resistor is 250 ohms, rated at 200 watts apiece. In series, they provide a dissipation rating of 400 watts. A slider on one of the resistors provides variable voltage to the grids of the 822's.

Only two a.c. control switches are required. One, marked "Fil.," controls not only all filament transformers in the audio cabinet but also the two power supplies. This filament switch is in series with the "plate" switch so that, as in the r.f. cabinet, it is impossible to apply grid and plate voltages to the various tubes without their filaments being lit. The single plate switch controls both the bias and plate-voltage supplies, since there is no point in being able to turn on the bias supply separately.

But three relays are required. Relay No. 1 is a 6-volt relay and is actuated from the relay voltage of this value furnished from the r.f. cabinet through the interconnecting control cable. This relay in turn actuates the power relay, which has a contact current carrying capacity of 25 amp., this relay being the main power control relay of the audio cabinet. Relay No. 2 is another overload relay, wired so as to open the 6-volt circuit to the coil of relay No. 1 when the plate current of the 822's goes above 500 ma. A protective door switch, cut into the same circuit in interconnecting lead M, also throws off the two power supplies when the door of the a.f. cabinet is opened. A point which we would like to bring out at this time is that, while the door switch of the a.f. cabinet controls only the power supplies in that particular cabinet, the door switch on the r.f. cabinet controls the power supplies of *both* cabinets. It is safe to leave the r.f. section of the transmitter running alone, but not safe to leave the a.f. section running by itself. This same relation holds also for the overload relays in the two cabinets.

Units G and H, although having separate panels to conform to the panels in the r.f. cabinet, actually form a single unit, the two sections of which are directly interconnected with flexible wires. The top section, G, holds only the output transformer T7, the filament-voltage and the plate-current meters M and M1, and the two plaque-type, non-inductive resistors R7 and R8. The purpose of these resistors is to prevent any tendency toward self-oscillation of this stage. A special mounting had to be constructed to support the output transformer T7, as it weighs over a hundred pounds. Four short lengths of 1/4 inch angle-iron do the trick. One piece goes across the front of the cabinet just behind the panel, and is bolted to the panel mounting holes. A similar piece of angle iron goes across the back of the cabinet, being bolted to the back edges by means of a hole drilled on each side. Two more lengths of angle iron go from front to rear and are supported by the cross pieces. These are spaced at such a distance that the mounting feet of the transformer may be bolted to them. This construction provides a really solid mounting for the modulation transformer.

The lower section of this dual unit, Unit H, holds only the two modulator tubes, V4 and V5, the input transformer T5 and the controlled-carrier Variactor T6; but

these few items are enough for a single chassis to support. The Variactor contains three windings, one of which goes in series with the positive, high-voltage lead to this stage while the other two are placed in series with the pair of vertical interconnecting leads J and K. This pair of leads runs back to the r.f. cabinet via the control cable and connects into the primary circuit of transformer T8, the power transformer for the final r.f. amplifier stage. The design of this Variactor is such that an increase in plate current to the 822's, which occurs during modulation, increases the current flow into the primary of transformer T8, this in turn increasing the input to the r.f. amplifier stage. The net result is that speaking into the microphone not only increases the input to the modulator stage in proportion with the strength of the voice tones, but also the input to the final r.f. stage. In this way the actual r.f. carrier strength of the transmitter varies according to the speech. The advantages of this system will be discussed in the final article next month. As the maximum voltage input to the primary of T8 is decreased approximately one-half, even under 100-percent modulation conditions, autotransformer T14 in Unit C is used to compensate for this voltage drop. This is merely a voltage drop, not a power loss.

Test procedure and adjustments for the r.f. cabinet were deleted from last month's article due to its length. The test procedure for both cabinets is the same and so will be covered together. The first thing to do is to test all the 115 volt AC circuits as well as the relay control. If these two cabinets are ready for test before the master control and speech amplifier Unit N is built the master control may be easily duplicated with but a switch and a key. For the amateur who is not interested in phone, and builds only the r.f. cabinet a simple remote control unit may be constructed to the builder's taste in a very small space.

To make up a temporary control plug, a cable into the socket on the lower back of the r.f. cabinet marked "to remote control." Wires 1 and 3 of this cable should connect to the "master control switch." As there is but 6 volts (at low current) to break, any type of switch that suits the builder's fancy may be employed for this purpose. A key, or another switch to duplicate the key for testing procedure, should be connected across wires 1 and 4. Again, the voltage across the key is but 6 volts.

With this temporary master control made up, the r.f. cabinet should be first tested with the a.f. cabinet not connected. The plate leads from the various rectifier tubes to their respective power transformers should be taken off. With the "Fil." switch turned on, and the three plate switches and the master-control switch open, the various tube filaments should be checked for proper voltage. The master-control switch should be next closed. This should close Relay No. 3 and Relay No. 4. Next an electric light bulb should be placed in a socket having two short leads for checking the various 115-volt a.c. circuits. With plate switch "LV" closed (master-control switch still closed) the bulb should light across interconnecting wires A and D. With switch "MV" closed, voltage should appear across A and E. With the "HV" switch closed and the "amp. switch" (controlled from the left-hand knob of the control unit) in the left-hand position, voltage should appear across A and F. Similarly, with this latter switch in the center position voltage should be across A and G. With the "amp. sw." in the right-hand position, 180 volts should appear across A and H. The bulb should be touched to these terminals only momentarily for this test

SELL BEFORE YOU BUY

How would you like to have a good stock of nationally advertised radio tubes on your shelves — *without paying a nickel until they're sold?*

That's how the Tung-Sol Consignment Plan works for radio dealers *who can qualify*. You don't pay for the tubes until you've collected your cost and profit. That's worth looking into — to see if you are eligible for this unique plan.

More than 8,000 dealers have qualified—and are going places in the tube business.

Full profit—no investment—no dead numbers to write off at a loss. Easy to sell, because your trade knows that Tung-Sol means top flight tube efficiency.

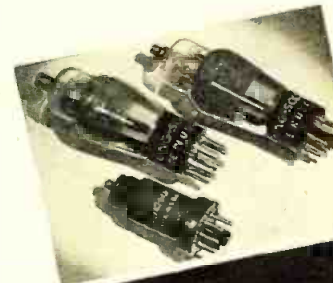

The Tung-Sol franchise is still available to a limited number of dealers who can qualify. Write for the name of your nearest wholesaler.

TUNG-SOL

Flow Radio Tubes

TUNG-SOL LAMP WORKS, INC.
Dept. G. Radio Tube Division
SALES OFFICES: Atlanta, Boston, Chicago, Charlotte, Dallas, Detroit, Kansas City, Los Angeles, New York.
General Office, Newark, N. J.

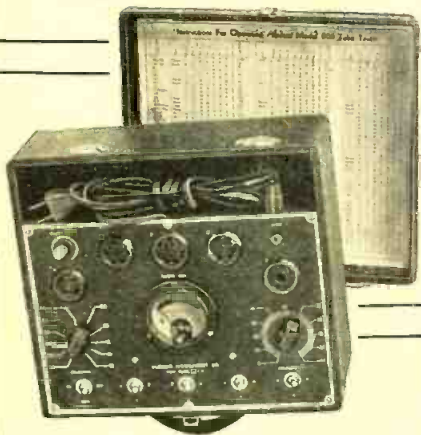
VALUE PLUS...**Elgin 800 Tube Tester**

- Tests All Tubes Including Metal
- D'Arsonval Moving Coil Meter
- English Reading "Good"-"Bad" Scale
- Separate Section Tests
- Accurate Tests on All Tubes
- Portable Leatherette Covered Case
- Compact—Can be Carried Anywhere
- Requires But Two Settings For Tests
- Combination Short Test and Meter Fuse
- Chart For Testing All Tubes

Complete Net Dealer's and Serviceman's Price..... **\$11.50****MODEL 801 Volt-Ohmmeter**

A sensitive, compact and accurate volt-ohmmeter that will be the busiest instrument in your "lab," or out on jobs. DC voltage readings -0.5-50-500 and 1000 - resistance readings from $\frac{1}{2}$ to 500 and 200 to 500,000 ohms. Will read from 0 to 1 Ma. Low resistance range direct reading. Meter has 1000 ohm per volt sensitivity. Battery is self contained. Panel is clearly lettered. Compensator provided for zero adjustment. Measures only $5" \times 3\frac{1}{4}" \times 2\frac{1}{2}"$.

DEALER'S NET PRICE WITH BATTERY..... **\$5.75**
Send for circular describing our complete line.**TRY-MO RADIO CO., INC.**
85N CORTLANDT ST., N. Y. C.**LEARN CODE**the way you'll be using it
by **SOUND**

There is only one way to learn to read code and that is by listening to code. There is

only one way to learn to send code and that is by hearing your own sending repeated back to you. With the new all electric Master Teleplex Code Teaching Machine you learn code the natural, easy, fascinating way. Only instrument ever produced which records your sending in visible dots and dashes—then SENDS BACK your own key work at any speed you desire. We furnish complete course, lend you the All Electric Master Teleplex, give you personal instruction with a **MONEY BACK GUARANTEE**—all at a surprisingly low cost per month. Write today for **FREE** catalog R.N.10 No obligation.

TELEPLEX CO.

72-76 Cortlandt St., New York City

RADIO ENGINEERING,

broadcasting, aviation and police radio, servicing, marine radio telegraphy and telephony, Morse telegraphy and railway accounting taught thoroughly. Engineering course of nine months' duration equivalent to three years of college radio work. School established 1874. All expenses low. Catalog free.
Dodge's Institute, Oak St., Valparaiso, Indiana

or it will blow out. A further check may be made of the controlled-carrier circuit by leaving the "amp. sw." in the right-hand position and temporarily shorting H and J. In this case the 180 volts will also appear across A and G.

The overload relay should next be checked for proper operation. It should be hand-operated for this test. With the contacts in the normal closed position the various test procedures just outlined will hold true. With the contacts of the overload relay opened, to simulate an extra load on the amplifier stage, neither Relay No. 3 nor Relay No. 4 can be closed with the master-control switch.

The underload relay No. 6, controls only the circuit running through the interconnecting control cable to the a.f. cabinet. For a test of this circuit, Relays Nos. 3, 4 and 5 should be in the closed position (with the master-control switch closed). Closing the contacts of the underload relay to simulate proper operation of the amplifier stage should place 6 volts a.c. across the control wires 2 and 5. It is a good idea to make this test reading at the "to a.f. control circuit" socket in order to check the cable running down from the control unit to these sockets.

One important test has been omitted. The door switch is connected into the 6-volt control circuit in the same relative position as the overload relay and the master-control switch. With this switch in the open position the relay circuit should be inoperative. It is a good idea to short-circuit this switch, temporarily, during preliminary testing of circuits as they must be made with the door open.

Various other tests may be made of the control and a.c. circuits. For instance, the "Fil." switch should shut off the entire transmitter, while the three plate switches should control only their respective power transformer primaries. Opening the master-control switch should remove all line voltage from these several transformer primaries, while the door switch and overload relay should do likewise. As all interconnecting wires are brought out to the back of the several chassis these tests may be easily and safely made with either an a.c. voltmeter or test bulb.

The control and line circuits of the a.f. cabinet may be tested in a similar manner. 6 volts of a.c. must be provided wires L and M of this cabinet in order to operate the relays. This may be taken either from the r.f. cabinet or, temporarily, from a separate 6-volt transformer. With 6 volts into wires L and M relays Rel. 1 and Rel. 1 should operate. Opening either or both the overload-relay contacts and the door switch should render the other relays inoperative. The two control switches on the control Unit panel of the a.f. cabinet should have no effect on the relay circuit. In the r.f. cabinet, remember, the filament switch shuts off the relay circuit.

With the "Fil." switch closed and the leads to the rectifier plates disconnected, the tubes should light. Closing the "plate" switch should furnish line voltage across interconnecting wires A and D, providing the relays are properly closed. Operation of the relay circuit should also control the voltage across A and D.

The next tests are for proper operation of the various power supplies in the two cabinets. The leads to the various rectifier tube plates should be replaced. This test should be made with a high range voltmeter, and **EXTREME CAUTION should be observed to prevent INJURY or POSSIBLE DEATH to the tester!** The proper voltages should appear on the various interconnecting wires between the units. In making these tests the various manual controls and relay circuits should be operated to make sure that these high voltages appear

only when they should.

Test of the complete audio cabinet may be more easily made than the corresponding test of the complete r.f. cabinet, due to there being actually but a single audio stage in the a.f. cabinet. In the preliminary test of this cabinet the only procedure necessary is to check as to whether the proper voltages and currents are being obtained or not. With the entire cabinet turned on, but with no input or output audio connections, the 822 modulator tubes should show, on the plate meter, the proper minimum current that is obtained with no audio input. If this is not correct the slider on the bias supply bleeder should be adjusted until the correct minimum current obtains. If the proper filament and plate voltages are also obtained in this test no further testing need be done until the entire transmitter, speech amplifier and all, is ready for the final phone operating check.

Parts List for Unit G

- M—Triplet 4-inch square bakelite-case meter, 0-750-ma. d.c.
- M1—Triplet 4-inch square bakelite-case meter, 0-15-volts, a.c.
- R7—Ward Leonard Plaque type resistor, 100-ohms
- R8—Ward Leonard Plaque type resistor, 100-ohms
- T7—UTC type PA-150T 750-watt Class B output transformer
- 1—14-inch x 19-inch black crackle aluminum panel, Parmetal
- C1A—2-mfd. 2500-V-working filter condenser, Cornell-Dubilier

Parts List for Unit H

- V4, V5—Taylor type 822 tubes
- T5—UTC type PA512 500-ohm line to Class B grids transformer
- T6—UTC type CV-6 controlled-carrier Variactor
- 2—Johnson type 211 sockets
- 14—Birnback type 4125 feed-through insulators
- 1—14-inch x 19-inch black crackle aluminum panel, Parmetal
- 1—11-inch x 17-inch x $2\frac{1}{2}$ -inch cadmium plated chassis, Parmetal
- 1—pair of brackets for above, Parmetal

Parts List for Unit J

- T4—UTC type CS-409 10-volt $6\frac{1}{2}$ -amp. filament transformer
- REL—Ward Leonard 115-V, a.c. coil, 25-amp. contact, DPST relay
- REL1—Ward Leonard 6-V, a.c. coil, 4-amp. contact, DPDT relay
- REL2—Ward Leonard 500-ma. coil, overload relay
- R4—Ward Leonard 20-ohm heavy-duty rheostat
- R5, R6—Ward Leonard 250-ohm 200-watt resistor
- 2—SPST, toggle switches, 15 amp.
- 1—General Radio type 637R knob
- 13—Birnback type 4125 feed through insulators
- 1— $8\frac{3}{4}$ -inch x 19-inch black crackle aluminum panel, Parmetal
- 1—17-inch x 11-inch x $2\frac{1}{2}$ -inch cadmium plated chassis, Parmetal
- 1—pair of brackets for above, Parmetal

Parts List for Unit K

- V2, V3—Raytheon type 866A tubes
- 2—Hammarlund type S4 4-prong isolantite sockets
- L2—UTC type CS-303 500-ma. smoothing chokes
- L3—UTC type CS-303 500-ma. smoothing chokes
- C2—Cornell-Dubilier triple 8-8-8-mfd. 450-volt-working elec. filter condenser
- C3—Cornell-Dubilier triple 8-8-8-mfd. 450-volt-working elec. filter condenser
- T2—UTC type LS-107 C-bias power transformer
- T3—UTC type PA-34 $2\frac{1}{2}$ -volt, 10-amp. filament transformer
- 7—Birnback type 4125 feed-through insulators
- 1— $8\frac{3}{4}$ -inch x 19-inch black crackle aluminum panel, Parmetal
- 1—17-inch x 11-inch x $2\frac{1}{2}$ -inch cadmium plated chassis, Parmetal
- 1—pair of brackets for above, Parmetal

Parts List for Unit L

- V, V1—Raytheon type 866 A tubes
- 2—Hammarlund type S4 4-prong isolantite sockets
- L—UTC type PA-109 500-ma. swinging choke
- L1—UTC type PA-108 500-ma. smoothing choke
- T1—UTC type PA-120 $2\frac{1}{2}$ -volt 10 amp. filament transformer
- R, R1, R2, R3—Ward Leonard 25,000-ohm 50-watt resistors
- 13—Birnback type 4125 feed-through insulators
- 1— $8\frac{3}{4}$ -inch x 19-inch black crackle aluminum panel, Parmetal
- 1—11-inch x 17-inch x $2\frac{1}{2}$ -inch cadmium plated chassis, Parmetal
- 1—pair of brackets for above, Parmetal

Parts List for Unit M

- C, C1—2-mfd., 2500-volt-working filter condensers, Cornell-Dubilier

- T—UTC type PA-114 3000-2500-0-2500-3000 500-ma. power transformer
- 1—7-inch x 19-inch black crackle aluminum panel

A.F. Cabinet and Accessories

- 1—Parmetal Deluxe cabinet
- 2—Hammarlund type S4 4-prong isolantite sockets
- 1—dual a.c. outlet, with plate
- 1—blank receptacle plate
- 2—National type XS-2 Steatite high frequency bushings
- 1—door switch

The Sportset

(Continued from page 203)

the various parts can be seen in the photographs. There is no over-crowding and the wiring presents no problem with the exception of the filament connections to the socket which should be made before it is fastened in place. The socket should be arranged with the two filament connections at the back which leaves the plate and grid terminals accessible on the left and right of the socket, respectively, as you look down on its side with the socket base toward you.

The grid end of the loop is brought through a small hole in the side of the case adjacent to the grid terminal of the socket to which it is soldered.

The filament resistor is below the 2.1 M.H. choke and lies along the angle formed by the partition and the back of the case.

Solid tinned wire is used for many of the connections, particularly to the choke, L2, which makes it unnecessary to fasten it down. Only a small amount of wiring is necessary with this lay-out, as the leads on the condensers themselves provide most of it.

The tuning is a bit unusual unless you have had experience with super-regeneration on the lower frequencies. C1 is of course the tuning condenser, while C2 controls the super-regeneration. And as there is bound to be some inter-action between these two it takes a little experimenting to learn the proper method of adjusting the receiver. You will catch on to it quickly, however, and a tedious explanation of exactly how to proceed hardly seems necessary.

Of course the super-regenerative circuit is not very selective but it does provide a surprising amount of sensitivity and with the small loop used you will have no trouble in separating the local stations. If more distant reception is desired, such as from a camp location, a short antenna may be connected directly to the grid in addition to the loop or a tap near the grid end of the loop may be provided.

You will be surprised at the versatility of this little receiver and the many uses to which it can be put. It is interesting to walk around with it and discover what effect various locations have on radio reception. You will often find spots in your home which give particularly good results due, perhaps, to wiring or a steel girder in the floor or wall which is acting as an antenna. You may also find that the antenna for your big set is not in the most favorable location; or, if you are planning on moving, why not give your prospective home site a radio survey and see how it stacks up?

You will find that this Pocket Sportset will give you good reception on the major local stations from most any location within reason, so don't forget it when you take in the World Series or the big foot-ball games this Fall. Slip it in your overcoat pocket so that the controls are at the top. Then with a single 1000-ohm receiver in the palm of your hand you are all set to

qualify as an expert on everything that takes place on the field.

Parts List

- 2—140-mfd. midget variable condenser—Hammarlund Star
- 1—.05-mfd tubular condenser
- 2—.004-mfd mica condenser
- 1—2,1-m.h. Choke—Hammarlund
- 1—20-m.h. choke
- 1—4-prong bakelite socket—I.C.A. No. 2480
- 1—S.P.S.T. Toggle switch
- 2—Pin jacks
- 2—No. 2 Burgess flashlight batteries (1½ volts each)
- 4—No. 22 Burgess flashlight batteries (3 volts each)
- 1—14-ohm resistor
- 1—Type 30 tube, Sylvania

Desk Phones

(Continued from page 215)

Chicago. While the model numbers discussed are those of instruments produced by his company, the principles involved will apply to practically all equipment in the wired-system category. Servicemen who wish to cash in on the tremendous demand for this new apparatus will find their installation problems greatly simplified by familiarizing themselves with these fundamental hook-ups.

Several Combinations

Several combinations representing a wide variety of practical installations are shown in the diagram. Their capabilities are described below.

SYSTEM A consists of one OXS and one OXM unit; a two-station installation only. Strictly an inter-communicating system, comprising two units and utilizing one amplifier. Meets ordinary two-station requirements.

SYSTEM E is a modification of System A. In this system the outlying station does not have a talk switch. A call can be answered without throwing any switch or going near the unit (satisfactory installation depends somewhat on noise level).

SYSTEM B consists of OXC master and OXM outlying stations. Strictly an intercommunicating system, utilizing one amplifier at the central location and may be employed with as many as 10 outlying stations. Outlying stations cannot converse among themselves, the system being intercommunicating only between the central station and outlying stations. Central station is only unit in system with selective switch, but outlying stations may call central station at will.

SYSTEM F is a modification of System B. In this system all outlying stations are without talk switch and cannot call the master station. They can answer a call from the master station without throwing any switch or necessarily going near the unit. (Satisfactory installation depends somewhat on noise level.)

SYSTEM D consists of three or more OCM units. An intercommunicating system, being a multiple of System C. These units differ from those of System C in that a selector switch is provided to contact the stations called. As many as 10 System D units may be used in one installation.

SYSTEM C consists of two OC units. An intercommunicating system for two-station installations only. Utilizes two amplifiers (differing in this respect from System A), making it possible for either station to call the other even though the switch at the location called may be "off," a feature not available in System A.

NOW READY

THE NEW SYLVANIA CHARACTERISTICS SHEET!



Let It Solve Your Tube Characteristics Problems!

No radio service man should be without this complete tube characteristics chart. It contains the very latest tube characteristics information available — information that can be found nowhere else.

COVERS MORE THAN 180 TYPES

The Sylvania Tube Characteristics Sheet suits service men to a "T." It covers more than 180 types . . . tube types are numerically listed . . . characteristics are tabulated . . . all characteristics and base diagrams are arranged on one side of the paper—*instantly available*. Also contains full information on the latest types of glass, metal and "G" tubes. Folds to pocket size—swell for your service kit!

Best of all, it's FREE! Just fill in and tear out the coupon below, and send it to us. You'll get your Characteristics Sheet . . . pronto!

SYLVANIA

SET-TESTED RADIO TUBES

HYGRADE SYLVANIA CORP. RN-107 Emporium, Penna.

Please send me a FREE copy of the latest Sylvania Tube Characteristics Sheet.

Name

Address

City State

Dealer Service Man

Amateur Experimenter

"LET ME TRAIN YOU *at home*
FOR A GOOD RADIO JOB"



Get in Line for Big Money!

Radio is growing fast. Modern receivers require thoroughly trained experts for service and maintenance. You can become such an expert... *right at home*... through R.T.A. methods and begin earning money almost from the start of your course. In a very short time you will

Be the ONE Man in 1,000

who understands everything there is to know in order to give quick "sure-fire" service to all kinds of receivers. You can be the one man who can take the service business away from the old-time radio "tinker."

No Experience Needed

Even though you know nothing about Radio now, you can quickly qualify the R.T.A. way to step right into a well paying position—or start your own profitable business. Use your spare time and

LEARN AT HOME

Most R.T.A. members start making money right from the beginning. The special servicing equipment which is supplied without extra cost makes this possible. Don't wait—get started now. Write today for our Interesting Radio Book FREE.

INCLUDED WITH OUR TRAINING



This efficient time-saving, trouble-finding Circuit Analyzer and Resistance Tester helps you to make money without delay.

Don't Put It Off—Send Coupon Now

RADIO TRAINING ASSOCIATION OF AMERICA
 4525 Ravenswood Ave., Dept. RN-107, Chicago, Ill.

RADIO TRAINING ASSN. of AMERICA
 Dept. RN-107, 4525 Ravenswood Ave., Chicago, Ill.
 Gentlemen: Send me details of your Enrollment Plan and information on how to learn to make real money in radio quick.

Name.....
 Address.....
 City..... State.....

Takes the Sock!



- ★ Porcelain-case mica capacitor. For those h.f. applications.
- ★ Minimum metal in h.f. field. Units rated in max. current-carrying capacity at 15 mc., 7.5 mc., 3750 kc. and 1875 kc.
- ★ In capacities of .00005 to .1 mfd. 2000 to 12500 volts D.C. test.

New CATALOG: 15th Anniversary Edition. 32 pages. Many new items. Ask your supplier or write us for copy.



American Broadcasting

(Continued from page 200)

speaker's chamber will also be on the second floor. Two small studios and the master control room will be on the third floor. The remainder of the third and fourth floors will be given over to an audition room and office space.

The KYW studios will incorporate what is known as the "Holmes system of sound isolation." This involves the suspension of studio shells by means of steel springs.

Licensed for 10,000 watts, the station has applied for a step-up to 50,000 watts.

Schenectady, New York, will also have a new NBC building to house Station WGY of the General Electric Company. This is one of the oldest 50-kw. stations in the U.S.A. and is well known to short-wave fans for its many programs routed over sister high-frequency stations.

The new building will be built on the G.E. grounds at the head of Erie Boulevard, one of the city's main thoroughfares. The studios will occupy a space of 20,000 square feet. The cost of the building and equipment is set at \$300,000.

Cleveland, too, joins the new studio parade with new headquarters for WTAM in the first four floors of the Guarantee Title & Trust Building, Dixie Highway at Ninth and Superior Streets. The studios will be ready by the end of 1937, according to NBC plans. Seven studios will be erected, the largest of which will seat 400 visitors. The engineering equipment and master controls will be in the basement. The first floor will contain five studios and reception rooms. The two largest studios will be on the second floor, while offices will be assigned the second and third levels. The lease also calls for the use of the roof. Exactly how the roof will be used was not stated, but it was disclosed that the studios, as well as the roof, will have "provisions for television facilities."

The cost of the WTAM improvements is estimated at between \$250,000 and \$300,000. The station is seeking Government sanction for erecting a new vertical antenna which NBC claims capable of providing, in effect, a two-fold increase of the station's 50-kw. power.

Still additional plans for new studios in other NBC and CBS cities are being made.

The Radio Beginner

(Continued from page 204)

raise the voltage. When the same circuit is connected to a d.c. line, the plug must be inserted so as to make the plate of the rectifier positive. Then the rectifier will be conducting continuously. If the plug is inserted incorrectly, making the rectifier plate negative, the rectifier does not conduct and the receiver is inoperative. The tube filaments will be lighted however. Under these conditions electrolytic condensers can safely be used because they cannot be exposed to a reversed voltage, the rectifier protects them. The available plate voltage is somewhat lower on d.c. than it was on a.c. since it cannot become higher than 115 volts minus the voltage drop in tube and filter.

A.c.-d.c. receivers have some special problems of their own. One of the greatest ones is the problem of grounding. Figure 3 shows that the negative terminal of the B— supply is tied to one side of the line. If the chassis is connected to B— as in a.c. receivers, this chassis may be "hot" because one side of the line is grounded and that is not necessarily the same side. Thus the chassis itself may be 110 volts negative with respect to ground. Obviously it cannot be grounded as is an a.c. receiver and it would be possible to obtain severe shocks from it. Also, accidental short circuits may occur if it should come in contact with any grounded objects. The aerial wire too must be protected by inserting a mica condenser in its lead. When the plug is correctly inserted in an a.c. line, these dangers may not be present, but if the plug is reversed they will all show up. The receiver works either way.

These dangers can be minimized in two possible ways. The entire chassis can be enclosed in an insulated cabinet, taking care that even the controls are insulated. Another way is to isolate the chassis from the circuit itself, mounting the tuning condenser on insulators. The chassis is usually connected to B— through a condenser and it can then be grounded.

Another problem is the heat from the dropping resistor which was explained above. Then, the fact that the receiver is connected directly to the line makes it more susceptible to noise in the line. An extra r.f. filter to reduce noise is desirable.

Finally, there is only a limited B— voltage available. Usually no more than 125 or 135 volts on a.c. and about 90 to 100 volts on d.c. This limits the possibilities of circuits and also makes it hard to obtain much output power. Until recently, there was only one output tube for the purpose, the 43 which was a power pentode delivering 0.9 watt. Now there have been several new tubes, the 25B5, 25B6 and 25L6 which make available an output of 2 watts for a single tube. The rectifiers for the circuit must have a cathode insulated from the filament. One of the most popular is the 25Z5 which contains two separate rectifier sections insulated from each other and from the filament. Operating the two sections in parallel as in Figure 3 makes the maximum current rating of the tube approximately 100 ma.

The Wien Bridge

(Continued from page 218)

restrictions in the frequencies to be compared, it being as simple to measure 568 as 500 cycles per second.

With more careful shielding of the leads from the ratio-box, use of resistance standards capable of accurate and finer subdivision, and correction for phase angle of condensers C_a and C_b, this method is capable of much greater precision than it has been attempted to obtain here.

Seeing America

Schenectady, N. Y.—Several months ago, General Electric short-wave stations started a series of American travelogue broadcasts to acquaint listeners here and abroad with the historic and scenic wonders of America. These broadcasts will be continued until November. The broadcasts take place over W2XAD and W2XAF every Monday, in French at 1 p. m., in English at 5:15 p. m., and in Spanish at 6:15 p. m., all E.S.T.

Radio in Sweden

Stockholm, Sweden—The new Swedish short-wave station at Motala has been operating since March 8. It transmits on a wavelength of 25.63 meters and on 49.46 meters with a power of 0.5 kw. The station relays the Swedish State program. Frank Hammar, Swedish engineer, who was engaged by Haille Selassie at one time, designed the equipment.

Becoming An Amateur

MANY short-wave listeners have written letters to the editors of RADIO NEWS within the last year asking for information on how to become an amateur. They ask such questions as: Is it necessary to take a course to own and operate an amateur station? Is there a charge for the license and where are examinations held? What does a transmitter cost? etc. Typical of these is a letter received from J. Donovan, a short-wave listener of Marquette, Mich. Mr. Donovan lists 10 questions which cover quite well any questions that might occur to the prospective amateur. The 10 questions and answers follow:

1—Q. Is there any branch of the government which trains young men for work in radio in exchange for labor? Is it possible to secure ordinary work in any of the large broadcasting stations and thereby come in contact with the mechanism and be able to learn a great deal about radio?

A. The military branches of the government train enlisted men in radio communication. It usually is necessary to have some knowledge of radio before obtaining a position with a broadcasting station. If in the operating division, a commercial operator's license is required which, of course, requires more advanced training than an amateur's license.

2—Q. Is the amateur field filled or are there still more needed?

A. There is no fixed limit to the number of amateurs that may be licensed.

3—Q. Is there any radio school which supplies the amateur station equipment with their course?

A. To our knowledge there is no school that supplies amateur equipment as part of its course in radio.

4—Q. About how much preparation and how many hours of study are necessary before one may operate a station?

A. The amount of time necessary for preparation to pass an amateur examination depends entirely upon the ability of the individual. Some persons have been known to start from "scratch" and qualify for license within three months. The most difficult part of obtaining a license is learning the telegraph code. A copying speed of ten words a minute (computed on the basis of five letters to the average word) is required.

5—Q. Are amateur stations easily moved from town to town? In some pictures the amateur stations appear quite untidy. Isn't there some means of covering all those wires and exposed parts?

A. Amateur stations are as portable as the average roomfull of furniture. Small amounts of equipment may be moved easily, but large stations have much heavy equipment and require the services of professional movers. The tidiness of an amateur station depends entirely upon the ingenuity of the owner. An amateur station may be constructed as neatly as a broadcasting station. Cabinets and panels may be used to cover exposed parts. There are a number of manufacturers making very neat transmitting apparatus designed for the amateur.

6—Q. Do you know of any amateurs who would be willing to work with a newcomer to the field in this territory?

A. We suggest you consult a call book for the location of amateurs in your vicinity. You will find most of them willing to help a newcomer.

7—Q. Will you please explain the DX Listening Posts? Is it necessary to be an amateur or serviceman to belong to these posts? Of what service are these posts to you?

A. The short-wave and DX Listening Post appointments are made in order to obtain up-to-the-minute information on stations being received. Each Listening Post Observer submits a monthly report, covering his best reception for the month and including announcements of frequency changes, etc., that he may hear during the broadcasts from the different broadcast and short-wave stations. Through this means we are able to keep our short-wave time-table up to date and all readers are further assured of the accurateness and timeliness of the information contained therein. A considerable amount of other information contained in the two DX Corners is obtained in this way. For appointment as an observer, a reader does not have to be either an amateur or a serviceman. He must convince us that he is a capable DX or short-wave listener, which is usually accomplished by sending us a brief summary of his best catches. The only other requirement is that he be willing to submit regular monthly reports. Each observer, upon being appointed, is provided with a certificate suitable for framing.

8—Q. Is the amateur's work of any benefit to the radio world in general? Will his work as an amateur aid him in getting into other fields of radio? Will it be of any assistance to him in the field of television?

A. Amateurs have contributed a tremendous amount to the development of radio. To cover their achievements would fill a large volume. One of their achievements was the development of short-wave communication which today is the backbone of international radio communication. Most of the prominent radio inventors and engineers are, or were at some time or another, amateurs. The prestige of being an amateur usually is helpful in obtaining employment in the radio industry. The knowledge gleaned by being an amateur undoubtedly will be helpful in understanding the intricacies of the television of the future.

9—Q. Is it necessary to learn code to be an operator?

A. It is necessary to learn the code to become an amateur. A receiving speed of ten words a minute is required. (See answer to 8.)

10—Q. Is amateur radio usually followed as a hobby or do many people give their full time to it?

A. Amateur radio is essentially a hobby.

New Peri-Dynamic Reproducers Now Available in Kits

The Jensen Radio Mfg. Company recently announced a new line of "Peri-Dynamic" reproducers available in kit form. The kit comprises the speaker and the complete housing, cut to size with all the necessary parts for assembly. The speaker cabinet is made of hardwood with outside surfaces finished with two coats of French gray. There are two models; model KM and KV. The first model uses both peri-dynamic and bass-reflex principles and is recommended for general use and where the utmost in the reproduction of music is desired. Model KV, employs only the peri-dynamic type principle and is suggested where reproduction of speech is of paramount importance. Jensen peri-dynamic reproducers are complete loudspeakers, no baffle is required.

This new design in compact speaker enclosure, provides results approaching those obtained with an infinite baffle.

Bad News for the Public Enemy

Saratoga Springs, N. Y.—At the Mayor's Conference of the State of New York, William H. Funston, Chief of Police of Schenectady, N. Y. spoke on the use of radio in police work. He stressed the advantages of two-way communication systems which is now possible by means of ultra-short waves. Equipment for this purpose was developed by General Electric and was recently installed in Schenectady. The Chief cited an example of a case in Boston where a criminal was fleeing after a hold-up, chased by a policeman in a radio-equipped police car. The officer called headquarters, gave the description and license number of the car and headquarters dispatched police cars to all the bridges leading out of the city. The robbers were duly arrested; time, 7 minutes. The teletype brought first news of the holdup to headquarters 8 minutes after the arrest was made.

Grid Bias Patent

New York, N. Y.—The U. S. Circuit Court of Appeals affirmed the decision of Federal District Judge Byers which held that six patents owned by the Western Electric Co., Electrical Research Products, Inc.; and the American Telephone and Telegraph Co. were valid and infringed by the General Talking Pictures Corporation, successor to the DeForest Phonofilm Co. The court held that the General Talking Pictures Corp. had infringed on the patents by leasing amplifiers to theatre operators while the company was licensed under the patents only for amateur, experimental and broadcast reception.

the New LAFAYETTE CO-ORDINATED SOUND SYSTEMS



The LAFAYETTE line, one of the oldest, most complete lines in the industry, has always meant progress... but never so much as in these NEW 1938 models. New colors... stream-lined designs... lightweight, sturdy, non-corrosive steel cabinets... special illuminated control dials... here are special features that make for EASY SELLING.

LAFAYETTE for a wider margin of profit byword of satisfied users

EASY TIME PAYMENT PLAN
NOW LAFAYETTE'S Easy Payment Plan, tailored to the needs of your business, will help you finance the "big" jobs.



HERE IT IS! FREE!
The Biggest Radio Catalog

ever assembled! 180 pages, with large separate P.A. section, 50,000 parts, 50 LAFAYETTE Radio models, test equipment... and all at lowest prices in history.

WHOLESALE RADIO SERVICE CO., INC.

NEW YORK, N.Y. CHICAGO, ILL. ATLANTA, GA.
100 SIXTH AVENUE 901 W. JACKSON BLVD. 430 W. PEACHTREE ST., N.W.
BOSTON, MASS. BRONX, N.Y. NEWARK, N.J. JAMAICA, L.I.

WHOLESALE RADIO SERVICE CO., INC.
100 Sixth Avenue New York, N. Y.
Rush FREE 1938 Catalog 69-2KA

NAME _____
ADDRESS _____
CITY _____ STATE _____



R. H. NITZSCHE

PRES. OF CREI

INSURE YOUR FUTURE! Start Training Now in PRACTICAL RADIO ENGINEERING

Do you ever sit down and "look your job in the face"? Are you satisfied with your present position, or anxious to get ahead? Today, you can't be satisfied, because rapid new developments mean Radio wants only men who are **TECHNICALLY TRAINED.**

Better Men Get Better Jobs

Right now is the time to start training—so you won't be left behind when others go ahead. CREI offers you home-training that will equip you to keep pace with Radio.

You Need Something More Than "Good Intentions"

It means study NOW, but your CREI diploma in Practical Radio Engineering will be the best reference you can possibly have. Radio Executives recognize the ability of CREI trained men.

CAPITOL RADIO ENGINEERING INSTITUTE

DEPT. RN-10
WASHINGTON, D. C., NEW YORK CITY
14th and Park Road 29 Broadway

RIGHT NOW---WRITE NOW!

Capitol Radio Engineering Inst., Dept. RN-10
14th and Park Road, N. W., Washington, D. C.
Please send me without obligation your Free Book—
"A Tested Plan for a Future in Practical Radio
Engineering."

Name.....
Address.....
City..... State.....

CORNELL-DUBILIER DRY ELECTROLYTIC CAPACITORS

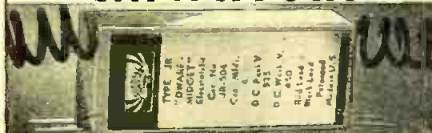

TYPE JR.

- Convenient mounting feet.
- Long color-coded insulated terminal leads.
- Smallest size... made possible by etched foil process of manufacture.
- Available in a complete capacity range at 250 and 525 volts Peak.
- Dual and multiple section units in popular capacity combinations.

Compactly designed for maximum utility, the Type JR capacitor will fill the majority of servicing requirement. Expensive delays and costly shopping tours are entirely eliminated by standardizing on C-D capacitors.

Have you received your copy of the New Catalog No. 151A? Many new innovations in condenser design, and the complete C-D line of capacitors illustrated in complete detail.

WORLD'S LARGEST EXCLUSIVE MANUFACTURER
OF CAPACITORS • MICA... DYKANOL... PAPER
... WET AND DRY ELECTROLYTICS.

CORNELL-DUBILIER
ELECTRIC CORPORATION
South Plainfield, New Jersey

WHAT'S NEW IN RADIO

WILLIAM C. DORF

(Continued from page 245)

over from 6-volt battery to 110-volt power-line operation. It is housed in a rugged metal case.

Cathode-Ray Analyzer

This new midget cathode-ray oscilloscope is manufactured by the Earl Webber Company. The instrument employs the new 2-inch cathode-ray tube and incorporates a number of new features which include separate amplifiers for the horizontal and vertical deflecting plates, a linear

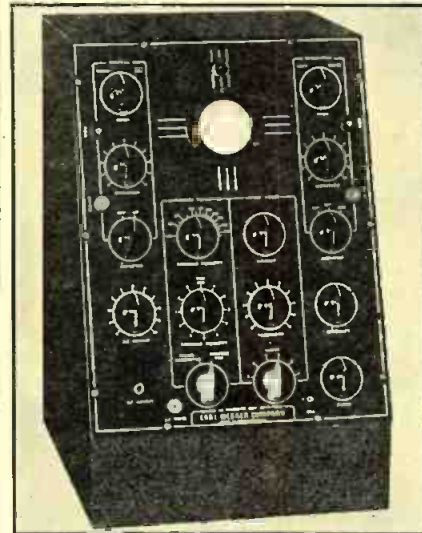

sweep circuit and an electronic "wobbler" (frequency modulator), which enables the oscilloscope to be employed with any all-wave signal generator for proper cathode-ray aligning of r.f. and i.f. circuits. Special facilities for auto-radio aligning are also provided.

Convenient Tuning with End-Table Radio

Radio enthusiasts will be interested in the new Fairbanks-Morse medal 6AC-7 end-table receiver. This smartly-modern

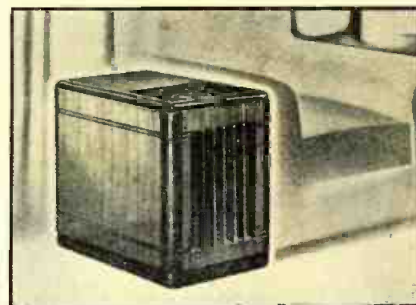

striped walnut cabinet houses a 6-tube superheterodyne, utilizing one 6A8G, one 6K7G, one 6Q7G, one 6F6G, one 5Y3 rectifier, and a 6G5 tuning eye. Its frequency range is from 540 to 18,300 kilocycles.

High-Fidelity Dynamic Mike

The latest Universal dynamic microphone is self-energizing, requiring no polarizing voltage. The manufacturer points out that the instrument is unaffected by heat or moisture and has no hum pickup. Specifications show the output minus 58 db. and the frequency response from 40 to 8000

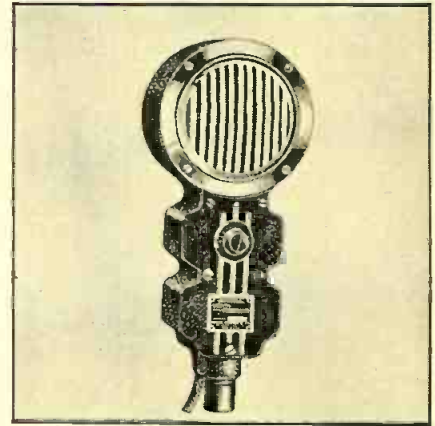

cycles. It is made with the following output impedances: high impedance, direct to grid, and 33, 50,200 and 500 ohms.

Combination Analyzer and Tube Checker

The Weston model 772 analyzer and model 773 tube tester are now available in a single portable carrying case. Though electrically independent, the two instruments form a balanced operating unit in function and design. The tube checker utilizes a large, easy-reading sensitive meter, is equipped with a rapid reference tube chart and neon short-check. The analyzer employs a 50 microampere meter, of 20,000 ohms per volt, has sensitivity resistance

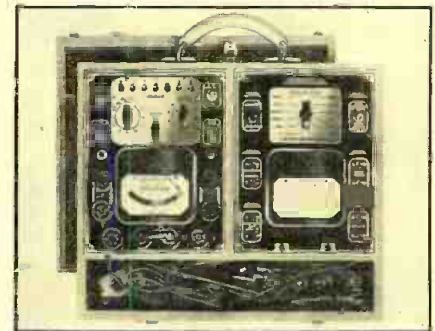

ranges up to 30 megohms, permits current measurements as low as 1/2 microamperes, and has other features.

Portable Sound System

This latest Webster Company model PA-712 sound system is complete with two speakers and microphone all enclosed in a single carrying case. Total weight of the system is 44 pounds. This is a four-stage, 12-watt job using beam power tubes. It is equipped with two high-gain input circuits for a crystal, velocity or Velotron microphone and a phono input, arranged for dual electronic mixing. A multiple outlet arrangement is provided for additional speakers.

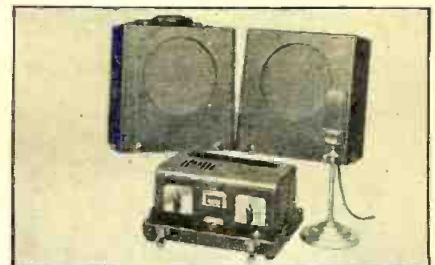

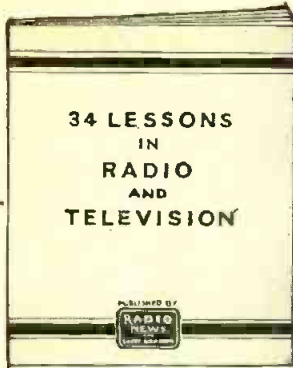

The "Inside" Story

Edition One, ten thousand copies, GONE! Edition Two, GOING FAST! That's the record of "34 Lessons in Radio and Television" in a nutshell! And, it's the "inside" story that is causing the great demand for this book—the long list of carefully edited, authentic

Contents

- Fundamentals of Electricity
- Vacuum Tubes
- Reception of Radio Waves
- Radio Symbols and Circuits
- Simple Diode (or Crystal) Receiver
- Operation of Vacuum Tubes
- A Simple Triode V.T. Receiver
- R.F. and A.F. Amplification
- A One-Stage Audio Amplifier
- How a Power Supply Works
- Operation of an Audio Amplifier
- Fidelity of Amplifiers
- Building an Amplifier-Power Unit
- Regeneration
- A Two-Tube Regenerative Tuner
- Operation of Pentode Tubes
- Advantages of Pentodes
- Simple Tuned R.F. Receiver
- T.R.F. and Superheterodynes
- High-Quality Broadcast Receiver
- Automatic Volume Control
- Oscillators and Mixers
- Facts About Antennas
- Photocells
- Breaking Into the Amateur Game
- Code Practice Oscillators
- History of Television
- Application of the Kerr Cell
- Scanning Disk Television
- Cathode-Ray Tubes
- The Sweep Circuit and Power Supply
- Cathode-Ray Television
- Television Receiver Design
- Television in the U. S.
- Television Abroad

Special Offer

Mail the coupon below for your copy of this valuable reference guide today—it's FREE to those subscribing now for 5 issues of RADIO NEWS.

RADIO NEWS, Dept. 3710
461 Eighth Ave., New York, N. Y.
Enclosed find \$1. Send me RADIO NEWS for 5 months and rush a copy of "34 Lessons in Radio and Television" to me free of charge. (Canada and Foreign \$1.25.)

Name.....
Address.....
City..... State.....
(If a Radio Serviceman, check here)



Low-Cost "Streamlined" Mike

The RCA "Aerodynamic" microphone is of the pressure operated type, with a frequency range from 100 to 6000 cycles, suitable for reproduction of both speech and music. It is sturdily constructed and is particularly fitted for outdoor use. The microphone is actually small enough to fit into the hand and weighs only a pound and a half. It measures 2 5/8 inches wide by 3 inches high. It operates at an impedance of 250 ohms.

New Audio Transformers Incorporate Many New Features

Many new constructional and design features are incorporated in the new line of Thordarson "Tru-Fidelity" audio transformers. Reversible single-hole mounting permits rotation of transformer so that any



hum that might be present can be minimized by turning the unit to a position of minimum stray coupling. Leads pass through this center mounting bushing, simplifying sub-panel connections. The transformer case is cast from a special material to provide maximum shielding. Transformers have dual-balanced coils to provide "hum-bucking". The manufacturer calls attention to the special winding and impregnating methods used in the construction of these new units, which they say make possible their extended frequency range and permit capacitative and inductive balance of the windings.

Tests All Types of Tubes

The Million Radio and Television Labs. has just introduced a new tube checker,

Announcing
THE NEW RIDER MANUAL

 **The Greatest ADVANCE SALE of any RIDER MANUAL**

Enthusiastic ordering even before it was published, that is the story of Volume VIII, out November 10th. Jobbers ordered heavily merely from a description of its contents. They visualized the value of the "plus" services which it offered to servicemen.

VOLUME VIII IN TWO SECTIONS

1. **MANUAL:** Over 1600 pages giving complete circuit information on 1937-38 models of over a hundred manufacturers.
2. **INDEX:** Of about 118 pages makes it easy to quickly find the data in all eight Rider Manuals.
3. **"HOW IT WORKS":** A separate section giving a description of the Technical Features of new sets, such as A. F. C.—motorized tuning, etc.

ORDER TODAY
\$10.00

VOLUME VIII
Rider
MANUAL
OUT NOV. 10TH

JOHN F. RIDER
Publisher
1440 Broadway, New York

 **OVER 1600 PAGES**



biggest opportunities still ahead

In a decade radio has become a giant industry. The opportunities created are being enjoyed by trained men. The International Correspondence Schools Radio Course, prepared by leading authorities and constantly revised, WILL MAKE YOU A TRAINED MAN! A fascinating book—FREE.

INTERNATIONAL CORRESPONDENCE SCHOOLS

Box 8282-S, Scranton, Penna.
Send me—free—information on subject checked:
 Radio Operator Radio Service Man
 Electrical Engineer

Name.....
Address.....

5 TUBE SUPER KIT

456 K.C. 15 to 50 Meters; 200 to 550 Meters
Kit consists of: I.F. Trans., Var. Condenser, Chassis Pan. Coils, Sockets, Padding, Filter and By Pass Condensers, Resistors, Power Trans. and Schematic Drawing.
All above parts with 6 1/2" speaker.....\$5.95
All above parts with 8" speaker.....\$6.95
25% Deposit Required With Order.

WRITE FOR OUR NEW 8 PAGE FLYER

ARROW SALES COMPANY

631 Washington Blvd., Chicago, Illinois

STANCOR TRANSFORMERS

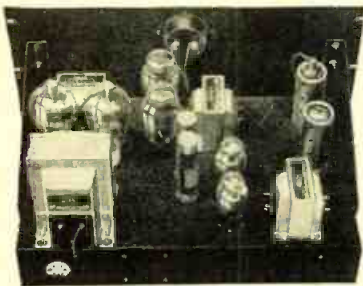

FOR THIS **\$12²¹**
**100 WATT
MODULATOR**

THIS inexpensive but efficient modulator delivers 100 clean watts of audio with 800 volts on the plates of the modulator tubes. Built on standard Relay Rack and Panel.

TUBES: 6C6 Pre-amplifier; 76 voltage amplifier; Push-Pull 76's; 6A3 Drivers; TZ-20 Class B Modulators.

STANCOR TRANSFORMERS: Push-Pull Input, XA4206; Push-Pull Interstage, XA4208; Push-Pull Driver, XA4212; Output, XA2908.

FREE BLUEPRINT AND LAYOUT TEMPLATE

**STANDARD
TRANSFORMER
CORPORATION**
850 BLACKHAWK ST., CHICAGO



C.W.
and
PHONE

TRANSMITTER KITS

*The Most Flexible
Transmitter Kits
Available Today*

80 Watts C. W. 80 Watts Phone
500 Watts C. W. 500 Watts Phone

- Self-Contained Power Supply for each Unit
- Designed for Rack Mounting, or Speech Amplifier may be located at operating station.
- Exciter Unit may be used as separate emergency unit or as 80 Watt Portable Transmitter
- No extra parts required when connecting for phone or C. W.
- Link Coupling used throughout
- Universal Antenna Coupler "link coupled"
- Every circuit properly metered
- No relay rack required for 5 Unit mounting
- All bands on 2 or 3 crystals
- No. 2 kit makes excellent amplifier for public address
- Simply and easily constructed
- Lowest prices

See these outstanding Transmitter Kits at your dealer today or write Dept. RN 10 for complete information.

UTAH RADIO PRODUCTS CO.

Chicago, Illinois

Toronto, Ont.
Canada

Buenos Aires
(Ucoa Radio Products Co.)

model CP designed to test all types of tubes including the latest octal base glass types. The instrument is equipped with a large English-reading "Good-Bad" scale to indicate the exact condition of the tube under test. There are short and leak-



age tests with the latter also available through external jacks for the measuring of resistance in continuity checks, shorted or leaky by-pass as electrolytic condensers.

Practice What They Preach

New York, N. Y.—At the IRE Silver Anniversary Convention, which was held at the Pennsylvania Hotel, an ultra-short-wave transmitter was used for those who discussed subjects from the floor. The transmitter was nicknamed the "beer mug" and was developed by NBC for remote control broadcasting. It is a small portable transmitter with a handle like a beer mug. The signal was picked up by a receiver in the same room and sent over the P.A. system.

The "beer mug" transmitter weighs less than 8 pounds, contains a high-fidelity microphone, audio-amplifier, crystal-controlled, master oscillator, r.f. amplifier and antenna. It also has an automatic volume control or "compressor." The power supply is included within the can; the range is one-half mile.

Read Classified Advertising—It Pays

Advertisements in this section sixteen cents a word for each insertion. Name and address must be included at the above rate. Cash should accompany all classified advertisements unless placed by an accredited advertising agency. No advertisements for less than 10 words accepted. Objectionable or misleading advertisements not accepted. Advertisements for these columns should reach us not later than 3rd of 2d month preceding issue.
TECK PUBLICATIONS, INC.
461 Eighth Ave. New York, N. Y.

Correspondence Courses

USED Correspondence Courses and Educational Books sold or rented. Inexpensive. Money-back guarantee. Write for Free Catalog listing 4000 bargains. (Courses Bought.) Lee Mountain, Pisgah, Alabama.

BIG BARGAIN Catalogue Courses 10c. Handling, 799 Broadway, New York.

Miscellaneous

ALASKA—The Last Frontier—For any information concerning Alaska, write The Alaskan, Box 332, Juneau, Alaska.

RADIO WRITING EXPLAINED. Script sample page. (Copyright 1937). Dime, and stamp. G. N. Alworth, 2019-A Highland Ave., Knoxville, Tenn.

Patent Attorneys

PATENTS—Advice and booklet free. Highest references. Best results. Promptness assured. Watson E. Coleman, Patent Lawyer, 724 9th Street, Washington, D. C.

PATENTS. Instruction "How to Establish Your Rights" and form, "Evidence of Conception" sent Free! Lancaster, Allwings & Rommel, 414 Bowen Building, Washington, D. C.

Patents and Inventions Wanted

INVENTIONS COMMERCIALIZED. Patented or unpatented. Write Adam Fisher Company, 278 Enright, St. Louis, Missouri.

Radio Instruction

COMPLETE TRAINING for all Amateur and Professional Radio Licenses. New York Wireless School, 1123 Broadway, New York.

INDEX TO ADVERTISERS

Aerovox Corporation.....	250	National Radio Institute.....	193
Akrad Products Company.....	234	National Schools.....	245
Allied Radio Corporation.....	227	National Union Radio Corporation.....	237
American Transformer Company.....	245	Newton Institute of Applied Science.....	240
Amperite Corporation.....	244	New York Y. M. C. A. Schools.....	256
Arrow Sales Company.....	253	Ohmite Mfg. Company.....	232
Brach Mfg. Company, L.S.....	256	Pioneer Gen-E-Motor Corporation.....	246
Brush Development Company, The.....	235	Post Radio Corporation.....	233
Cameradio Company.....	230	RCA Institutes, Inc.....	234
Candler System Company, The.....	240	RCA Manufacturing Company.....	228
Capitol Radio Engineering Institute.....	252	Radio City Products Company.....	234
Central Radio Laboratories.....	240	Radio Service Institute.....	232
Chicago Wheel & Mfg. Co.....	256	Radio Technical Institute.....	238
Cornell-Dubilier Corp.....	252	Radio & Technical Publishing Company.....	228
Coyne Electrical School.....	243	Radio Training Ass'n of America.....	230
Classified Ads.....	254	Radolek Company, The.....	255
Dodges Institute.....	248	Raytheon Production Corporation.....	241
Eastern Radio & Television Company.....	256	Readrite Meter Works.....	245
Goldentone Radio Company.....	256	Rider, John F.....	253
Hallcrafters, Inc.....	Back Cover	Scott Radio Labs, Inc. E. H.....	195
Hammarlund Mfg. Company.....	242	Sevan Company.....	228
Hetro Electrical Industries, Inc.....	242	Silver Corp., McMurdo.....	235
Hygrade-Sylvania Corporation.....	249	Solar Mfg. Corporation.....	230
International Correspondence Schools.....	253	Sprayberry Academy of Radio.....	256
Instructograph Company.....	236	Standard Transformer Corporation.....	254
International Resistance Company.....	255	Superior Instruments Company.....	237
Kato Engineering Company.....	256	Supreme Instruments Corporation.....	233
Kenyon Transformer Company, Inc.....	246	Teleplex Company.....	248
Lincoln Engineering School.....	236	Triad Mfg. Co., Inc.....	245
McElroy, T. R.....	256	Trimm Radio Mfg. Company.....	231
McGraw-Hill Book Company, Inc.....	238	Triplet Electrical Instrument Company.....	197
Mallory & Co., Inc., P.R.....	198	Tri-State College.....	228
Meissner Mfg. Company.....	236	Try-Mo Radio Company, Inc.....	248
Metal Cast Products Company.....	231	Tung-Sol Lamp Works, Inc.....	247
Midland Television, Inc.....	231	Utah Radio Products Company.....	254
Midwest Radio Corporation.....	Inside Back Cover	Webster Company, The.....	239
Million Radio & Television Lab.....	238	Weston Electrical Instruments Corp.....	Inside Front Cover
Modell's.....	231	Wholesale Radio Service Company.....	229, 251
		Wincharger Corporation.....	235
		Wright-DeCoster Co., Inc.....	244
		Zenhyr Radio Co.....	256

The RADIO WORKSHOP

(Continued from page 212)

it is difficult to set the chassis in such a way that it will not fall or damage the parts. This is especially true of some Philco sets, and in some of the sets where the power tube is mounted on top of the transformer, it is next to impossible to turn the chassis over or stand it on end.

Here is a home-made chassis cradle costing less than \$1.50 and applicable to all receivers. It permits under-chassis work without danger or harm to the set. First secure two pieces of hard wood, one 3/4 inch thick by 18 inches square and the other piece 2 inches thick by 14 inches square. In the second piece bore 49 holes 7/8 inch in diameter, two inches apart, center to center. When this job is done, secure it to the larger board with 2-inch screws. This leaves 2 inches all around the base so that it can be fastened to the workbench.

The next thing to do is to secure a round mop handle or any good round piece of hardwood 7/8 inch in diameter. Cut the handle into four 11-inch pieces and tack the suction cups to the ends of these cradle supports as illustrated. These suction cups are usually found on ash trays made for automobiles and on signs that are fastened to show windows. Set the uprights with four suction cups in the most convenient spaces on the chassis permitting a grip and in the nearest hole in the base and the receiver is ready to service.

O. GILBERT FILE,
Warsaw, N. C.

Modernizing the Loftin-White Tuner

From all reports, there are still a large number of radio listeners using old Loftin-White tuners, and they should be interested in the improvements made in this circuit by Gerard Kelley, one of the original members of the Loftin-White Laboratories. The May and August 1937 issues of RADIO NEWS feature articles by him on a new type of direct-coupled amplifier.

These changes are applicable to any similar tuned radio-frequency circuit and the use of the new tubes makes it possible to include automatic volume control and provide better all-around operating results.

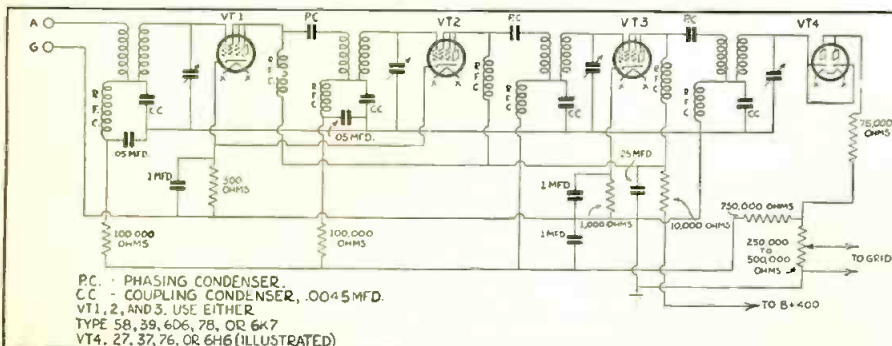

To make the revision, simply follow the schematic circuit. It is only necessary to replace the sockets and connect the volume control in the audio section of the diode detector, as shown. The 58, 39, 6D6, 78, or 6K7 tubes can be used in the r.f. stages. It will be noted that the tubes are not employed as pentodes but as triodes with the screen and suppressor grids tied to the plates.

The type 6H6 tube proved to be the best diode detector for this circuit and for uniformity the 6-volt series of tubes were used in the 3 r.f. stages. All the heaters of the tubes are connected to a convenient filament supply, the center-tap of which is grounded.

The 56 or 76 type triode tubes were not used because they offered no real advantage either in operation or in control. It was not possible to use the high- μ type tube as a pentode due to the low value of the inter-stage coupling, which figures about 1200 ohms, while the plate resistance of the average pentode is of the order of 1/2 megohm. To replace the r.f. transformers would involve too many changes and add materially to the cost of the revision.

Attention! Experimenters

THE "Radio Workshop" is a department which caters especially to the experimenter. Send your ideas, kinks and hints to the editor of this department, and wherever possible include a simple but clearly defined drawing or a photograph of the idea. All ideas published will be paid for at regular space rates.

In This Department Each Month!

A series of short articles will be included, one each month, telling "How to modernize" various past models of receivers.

EFFECTIVE IMMEDIATELY...



Metallized TYPE

CONTROLS

... are available in a complete line of exact duplicate replacement types.

... also, hot off the press comes the new IRC Control Guide listing replacements for almost every receiver.

Ask your jobber—or write direct to us—for a free copy of the Guide. Prepare to use the finest proved controls on EVERY job!

INTERNATIONAL RESISTANCE CO.
401 N. Broad Street • Philadelphia, Pa.



Everything NEW in Radio



NEWEST BOOK The Radolek 1937 Profit Guide is the most complete and up-to-date radio parts book ever published. 164 pages of radio buying information. TECHNICAL information and helps for servicemen are featured throughout the book.

12,000 PARTS The Right replacement items for every radio that you will service. A complete new selection of Receivers, Amplifiers, Test Equipment, Tubes, Tools, and Books—always in stock—ready for prompt shipment.

FASTER SERVICE Radolek SPECIALIZES in serving the radioman. Our organization is geared-up to serve you best—to give you what you want when you want it and at the RIGHT PRICES. This BIG new book is FREE! Send for your copy NOW!

RADOLEK

601 W. Randolph, Chicago, Dept. B-10

Send me the Radolek Radio Profit Guide FREE.

Name.....

Address.....

Serviceman? Dealer? Experimenter?

I OFFER YOU A NEW SECURITY ACT!



FORGET OLD AGE AND UNEMPLOYMENT
GET INTO RADIO NOW!

I'LL TRAIN YOU AT HOME, SPARE TIME, FOR A BUSINESS OF YOUR OWN

Don't wait for old age "Security." Radio's great opportunities, combined with my great new Radio Training, can quickly give you \$15 to \$25 weekly in spare time, \$35 to \$60 in salary, or a real **RADIO BUSINESS OF YOUR OWN.** That's the "Security Act" I offer you. Hundreds of men like you are cashing in on it right now.

BIG PROFESSIONAL OUTFIT!
I train you right at home with advanced methods. Course includes outfit consisting of tools, Triplett Tester, 7 Rider Manuals, Eby Electric Eye, etc. Everything you need. Makes "go-getters" out of beginners; experts out of experienced men.

SPECIAL SERVICEMEN'S COURSE
Learn the newest circuits, newest methods and short-cuts. Special course for servicemen. Terms low as \$3 per month. All courses, features, etc., fully described in big 48-page FREE book. Send for your copy TODAY!

Mail Coupon Now

F. L. SPRAYBERRY, PRES.,
Sprayberry Academy of Radio
25-L University Place, N. W.,
Washington, D. C.

Send me a FREE copy of "More Money in Radio", and facts about your new type of training.

Name..... Age.....
Address.....
City..... State.....

REPLACE WORN-OUT DOWN-LEADS WITH LYNCH GIANT KILLER CABLE

A worn out down-lead mars reception. Insure full signal strength by using Giant Killer Cable.

World's Largest Makers of Antenna Systems

L. S. BRACH Mfg. Corp.
Newark, N. J. Est. 1906

HERE'S YOUR RADIO!

Famous ZEPHYR RADIOS 50% off
All NEW models, latest features, AC-DC. All Electric. Battery or Auto Radios with Money Back GUARANTEE. Write for FREE catalog showing complete line. Ask about our Agent-User plan.

ZEPHYR RADIO COMPANY
13137 Hamilton Ave., Detroit, Michigan

The Amateur Observer

(Continued from page 210)

CX2AK, CE1AR, CE3AA, PK1MN, PK4DR, VS2AK, YI2BA, EA9AH, FA8AR, SU1CH, SU1KG, SU1RD, FT4AR, CN8MU, CT1CV, CT1JW, CT100, CT1AQ, CT1AY, F8PU, F8ZM, F8KW, F8QD, G5BJ, G5PT, G6AG, G6FS, G8BX, GNOP, G8BP, G15QN, EI2L, EI3I, SV1CA, SV1KE, PAOEO, PAOWC, PAOAD, PAOXF, SM7YA, ON4DM, EA7BA, IIRB, HB9AD, HB9AK, PILJ, VK2XU.

By William Skinner, 5950 Seminole Avenue, Detroit, Mich.
20 meters: K7FBE.

By M. J. Markuson, Fitzsimmons General Hospital, Denver, Colorado

20 meter phone: NE1LK, NE1AK, NE1BC, NE1F, NE1L, NE1GK, NE2BJ, NE2FC, SE2AH, NE2JK, CO2LY, CO2BY, CO2MT, CO2JV, CO2CC, CO2AU, CO2VP, CO8MA, CO8OG, CO8YB, HK3JA, HK1JW, HK3RC, K6GAS, K6AIA, K6OOE, K6OQW, K6KMB, K6IUY, K6BAZ, K6BNR, K6JLY, K7FBE, K7FSX, KA1ME, LU1HI, LU4BH, LU1QA, OA4AD, OA4C, OA4AL, OA4AK, PK6CI, TI2RC, TI1AE, TI2KP, TI2LR, TI3AV, VE4KF, VE3QZ, VE5BF, VE1LR, VE3EO, VE3KR, VE3AR, VE4AQ, VE5OT, VE5PE, VK6MW, VK2ABD, VK4JU, VK2ABG, VP5PZ, YV1AA, YV1AP, YV3AE, ZS5AB.

By Dan T. Wollenschlager, 448 Bannoch Street, Denver, Colorado

20 meters: NE1BC-3, NE1JK-4, K6NTV-3, K7ESK-3, CO2VW-4, OA4C-7, VK2UC-3, VP5PZ-7.

By Elmer R. Fuller, 29 Pearne Avenue, Cortland, N. Y.

20 meters: K4SA-9, K4ENY-9, K6OOE-8, VP5BZ-8, VP9R-9, H15X-9, LU1EX-7, LU7AC-8, LU8AB-7, PY1FR-8, VO4A-8, C13AV-8, W7EHL-6, YV5AK-6.

By Thomas P. Jordan, 1523 N. Main Avenue, Scranton, Pa.

10 meters: W4APR-7, W9TTB-8.
20 meter phone: G8LX, VP3BG, OA4N, CE3DW, LU7AC, EA9AH, VP2CD, PY1FR, W1ONDA.

By Norman Gertz, 355 Douglas Avenue, Providence, R. I.

5 meters: W1HDF, W1IJ, W1JLK, W1MY, W2EJP, W2JCY, W2MO, W2JVZ, W2RB, W2CUZ, W2AMJ, W2HEJ, W2CUF.

By H. Kemp, 250 Walnut Street, Waterbury, Conn.

LU1QA, LU4BL, LU6KE, LU7AZ, LU8LU, K6OOE, K6JLV, K6MDV, K6NZQ, K6NZV, K6CMC, K6BNR, H15X, H1G7, VP3BG, VP5PZ, VP6VB, VP7NA, VP9R, YV1AA, YV5ABE, YV5ABT, YV5AG, CE1AR, CE1AO, CE1AH, G2PU, G2BH, G5KH, G5SA, G6GL, G6OS, EA8AE, CT1AY, VE5TV, VE5OT, VE5EF, CX2AK, PY2FF, PY2ET, VK2RJ.

By William L. Bauer, 616 S. Eaton Street, Baltimore, Md.

20 meters: EI2J, HK2RS, VK2IO, SU1CH, F3JD, PAOXF, OA4R, PY2CK, YV5AK, ON4VK.

By John S. Dunn, Highlands, Banks Lane, Riddlesden, Keighley, Yorkshire, England

20 meter phone: W1HPB, W2IWT, W2DH, W3ANH, W3LN, W4CRA, W4GT, NY2AC, PY2BA, H15XY, Y12BA, CN8AM, CT1AY, CT1GU.

By Harry Honda, 325 Jackson Street, Los Angeles, Calif.

20 meter phone: H15X, H1G7, K4SA, K6OQU, K6NKN, K7FVE, VK1VM, VK2ABG, VK6MW, PY2ET, PY7AY, W1ONDA, KA1ME, KA1HS, VE5OT, VS4CS.

By G. H. Russell, 938 Philadelphia Road, Easton, Pa.

20 meters: W1JA, W1OC, W2FKL, W3EZQ, W4BTT, W4BRZ, W4CTG, W4KR, W4ENQ, W4DQT, W4CYU, W4BE, W5AWP, W5BRC, W5DAN, W5FPO, W5BEH, W5CYP, W5EOW, W5LPI, W5LBI, W9AED, W9VO, W9FXT, W9FJK, W9UOH, W9VNZ, W9VOD, W9RNX, W9BDE, W9GFC, W9UYE, W9SBV, W9NNV, W9FAY, W9SBZ, W9CUN, W9TM, G12A, VE1GP, VE3DP, VO2Z, CO2EG, X15X, XELFG, LU4KA, OA4N.

Electrad

New York, N. Y.—P. R. Mallory & Co., Inc., Indianapolis, announce the purchase of the assets, good will, trade-marks, patents and patent rights of Electrad, Inc., New York City. L. A. de Rosa, Chief Engineer, and other key employees of Electrad, Inc., will join the Mallory organization. Plant and offices will be moved to Indianapolis.

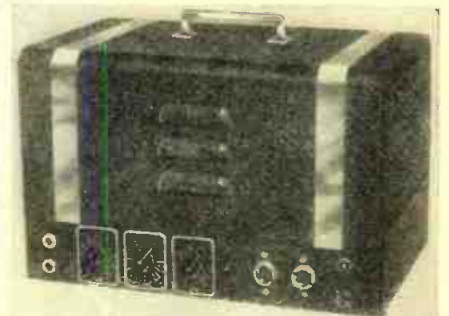

DEVELOPED for HIGH FIDELITY
and \$1745 from factory only to you
A 30-WATT AMPLIFIER

Completely assembled but not wired
New circuit incorporating the new Sylvania 1221 non-microphonic input pentode which permits you to use full gain on this powerful four stage amplifier. Push-pull 416 output with two input channels and faders for any type of microphone, radio or phonograph pick-up. Here is a rare opportunity for anyone needing a powerful, high quality amplifier.

K-30 HIGH FIDELITY AMPLIFIER: Assembled complete with wiring diagram and instructions, less only wiring, chassis cover and tubes.....\$17.45
Heavy gauge chassis cover, as illustrated.....\$3.25
Complete set of matched Sylvania tubes:
1-1221, 3-6C5, 2-6L6G, 1-5Z3.....\$4.10

EASTERN RADIO & TELEVISION CO.
136 Liberty St., New York, N. Y.

HANDEE

Tool of 1001 Uses

A whole shop full of tools in one. Does away with slow hand work. Plugs in any light socket AC or DC, 110 v 13,000 r.p.m. Uses 200 different accessories—grinds, polishes, routs, drills, cuts, carves, sands, saws, sharpens, engraves.

For Faster Better Jobs

Get A Demonstration at Hardware, Dept. Stores, Tool Dealers or order on 10 Day Money-Back Trial. \$10.75 and up postpaid. 3 Accessories Free. DeLuxe Model \$18.50, with 6 Accessories. Catalog Free.

CHICAGO WHEEL & MFG. CO., 1101 W. Monroe, Dept. AB, Chicago

110 VOLTS A. C.

Anytime! Anywhere! With KATOLIGHT PLANTS

350 watt 110 v. 60 cycle A.C.	\$89.60
300 watt 32 volt DC plant	78.40
15 amp. 12 volt charger	59.95
25 amp. 6 volt charger	49.95
AC & DC Generators	Rotary Converters
12 Volt 200 Watt Wind Plant	\$141.00

Write For Details.
KATO ENGINEERING CO.,
Mankato, Minnesota, U. S. A.

RADIOS..SAVE UP TO 50%

DEAL DIRECT...FACTORY PRICES: Many models to select from: AC-DC; All-Wave; armchair models; automatic tuning; car radios; Farmsets that operate like city radios! Send postcard for NEW Bargain Catalog FREE. 30-DAY TRIAL plan and agent-user proposition!

GOLDENTONE RADIO CO., DEPT. A10, DEARBORN, MICHIGAN

30 DAY TRIAL \$6.98 UP

Free Catalog

RADIO COURSES

RADIO OPERATING: Prepare for Gov't License Exam. ● RADIO SERVICING: Including Short Wave ● AMATEUR CODE ● ELECTRONICS ● TELEVISION

Day and Evening Classes—Booklet Upon Request

NEW YORK Y.M.C.A. SCHOOLS
7 W. 63rd Street, New York City

\$100 for a RADIO KEY!?

WORTH IT, but I only charge \$9.50

This semi-automatic key makes it easy to send dot stabilizer equipped. Selected main-spring. Marbleite finish base stays put. Chromium metal parts. Proper height for tireless, rhythmic sending. New 1938 Mac Key only \$9.50. Order Today! Also New Mac Straight Key—best ever—only \$2.50. Mac Oscillator \$4.50. Immediate delivery. Write for complete details on other Mac items of tremendous help to radio ops.

T. R. MCELROY—175 Congress St., Boston, Mass.
WORLD'S CHAMPION TELEGRAPHER

JUST TOUCH BUTTON

LATEST 18-TUBE MIDWEST TUNES ITSELF BY ELECTRIC MOTOR!

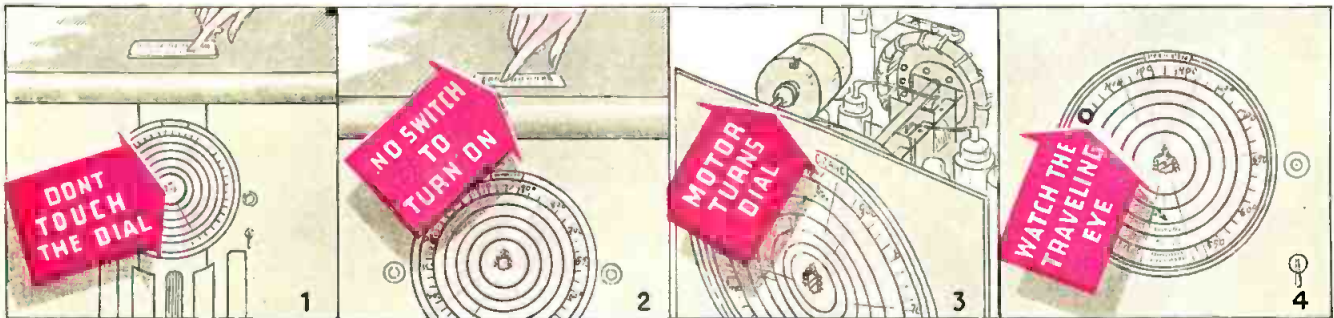

Only **MIDWEST'S** Direct-From-Factory Policy Makes This And Other Sensational Features Possible At Amazingly Low Prices!

"The sensation of the radio world" . . . that's what experts said when they saw the amazing new 1938 **MOTORIZED** Midwest. No more dial twiddling — no more squinting! Now, you can enjoy the luxury of radio at its best—you can tune your Midwest by merely touching a button! You'll be astounded at the lightning-like motorized action — just touch a button (on top of the radio) . . . and its corresponding station zips in.

Zip . . . Zip . . . Zip . . . you can bring in 9 perfectly tuned stations in 3 seconds! *All this happens in 1/3 second with Midwest Perfected Motorized Tuning.* (See above illustration). (1-2) You touch button; (3) Electric motor speeds dial towards corresponding station; (4) Colorful Bull's Eye darts across dial and locates itself behind station; (5) Dial *stops itself* at the station's exact center of resonance and the eye "winks" as program comes in perfectly tuned.

30 DAYS FREE TRIAL—
Enjoy World's Most Advanced Radio for 30 Days in Your Home! Don't Risk a Penny!

Act at once on this unusual factory-to-you offer. We send any Midwest radio you desire to your home. You use it 30 days, and compare it with other radios you have owned or heard. Then, you can return it to the factory, if you wish, without risking a penny. We trust you to give the Midwest a fair trial. You are triply protected with Foreign Reception Guarantee, One-Year Warranty and Money-Back Guarantee.

18 TUBES FOR PRICE OF 10

Why be content with an ordinary 10, 12 or 14-tube set when you can buy an 18-tube Super DeLuxe 101-feature Motorized Midwest for the same money. It will surprise and delight you with its brilliant world-wide reception on 6 bands, and a range of 12,000 and more miles! It will thrill you with its marvelous 6-continent overseas reception. Secures American, Canadian, Police, Amateur, Airplane, Ship broadcasts . . . and finest Foreign programs. You have a whole year to pay for your Midwest on easiest, most convenient credit terms. Never before have you been offered so much radio for so little money!

[SERVICE MEN: Join nation-wide Midwest service organization. Write for free details.] **SEND FOR FREE 1938 CATALOG**

The famous Midwest factory-to-you plan, proven by 18 years of success) is just as exciting. It enables you to buy at wholesale prices — to save up to 50% — to make your radio dollar go twice as far — to enjoy 30 days **FREE** trial in your own home—to pay as little as 50c a week.

18 Tubes
6 WAVE BANDS
only
\$39⁹⁵
(LESS TUBES)
FACTORY-TO-YOU
NEW LOW BASE PRICE CHASSIS

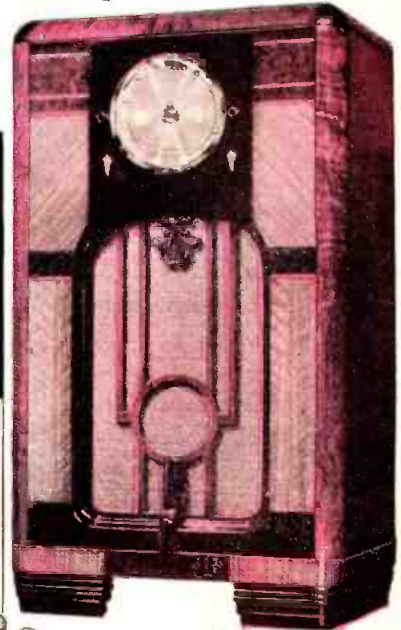

TERMS
As Low As
50c
A WEEK!
Send No Money Now!

MIDWEST
WORLD-WIDE RADIOS
MIDWEST RADIO CORPORATION
DEPT. EE-11
CINCINNATI, OHIO, U.S.A.

PASTE COUPON ON 1¢ POSTCARD...OR WRITE TODAY!

MIDWEST RADIO CORPORATION
Dept. EE-11 Cincinnati, O

Name

Address

Town..... State.....

User-Agents Make Easy Extra Money. Check Here for details
 Check Here for 1938 BATTERY catalog

We didn't write this page —

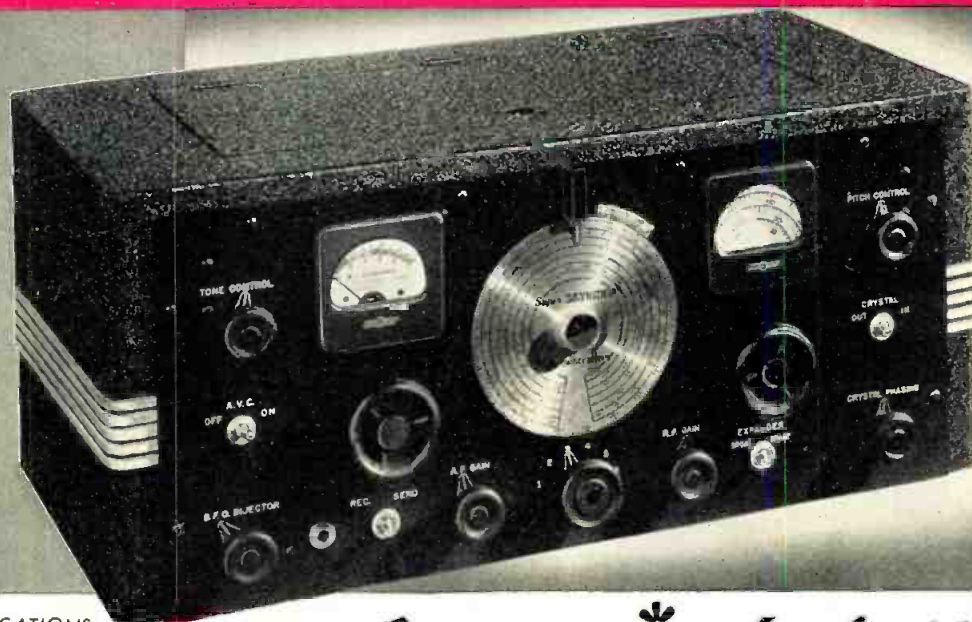

OTHER COMMUNICATIONS RECEIVERS OF THE FAMOUS HALLICRAFTERS FAMILY

THE SKY CHALLENGER

A 9-Tube Superheterodyne that has everything! Covers entire spectrum from 38MC to 535 KC (7.9 to 540 meters), everything from the increasingly popular new 10 meter band to the top of the broadcast band without a skip. Easy tuning with a smooth electrical band spread and 5 Band 338° Dial. Will outperform any receiver in its price class and many costing much more.

THE ULTRA SKYRIDER

A definite advance in Ultra High Frequency Reception. Tunes in 5 Meter stations with no more trouble than you'd find on lower frequencies. Tuning Range 5.65 to 79.5 MC (3.75 to 53 meters). 4 Band 338° Dial. 10 Tubes. Built in Noise Silencer, Electro-Mechanical Band Spread. Iron Core I.F. Transformers.

THE SKYRIDER COMMERCIAL

A "professional" type receiver covering the frequencies of 100 KC to 11.5 MC (3000 to 26.1 meters) on 5 bands with splendid sensitivity and selectivity. 1600 KC. Iron Core I. F. Transformers. Direct-Calibrated 338° Main Tuning Dial. Electric-Mechanical Band Spread. With the Ultra it provides complete coverage of the radio spectrum.

THE SKY CHIEF

A complete 7-Tube communications receiver with every control needed for efficient short wave reception, covers all frequencies from 18 MC to 540 KC. Amazing sensitivity and selectivity for a receiver in this low price bracket. Built-in Speaker and Hum-Free Power Supply.

THE SKY BUDDY

Junior Model Communications receiver that's ideal for the beginner and Short Wave Listener. Tunes from 545 to 18.1 MC (16.6 to 555 meters) in 3 Bands. A 5-Tube Superheterodyne with sensitivity and selectivity that's comparable to that of much higher priced receivers. 36 to 1 Mechanical Band Spread. Built-in Speaker and Hum-Free Power Supply.

Owners of the New
1938 SUPER SKYRIDER
did it for us!

● Says **W5APM** "I cannot help but congratulate you on this most wonderful communications receiver: The photos and descriptions of it do not do it full justice: In my opinion it represents the very best value obtainable at any price." ● **W1HWZ** and **W1DFS** add "The audio quality surpasses anything we have ever heard. The band spreading is the best ever. We heard about 15 Five Meter Stations and could read most of them on the 'broad' IF position." ● **W9ARA** contributes "I have just received the SX-16 and it is everything I expected it to be. You are going to sell a great many of them." ● From **W3GWP** "Vy. fb. Like it very much 73." ● From the 6th District, J. C. Heath, Salt Lake City, sends this "Think your bandspread a remarkable device and the entire set is built like a precision instrument". ● **W2BTP** adds this "Am very pleased with the receiver".

* These are but a few of the unsolicited comments on the New 1938 SUPER SKYRIDER.

OTHER PROMINENT AMATEURS NOW OPERATING 1938 SUPER SKYRIDERS					
W9UZ	W8MNX	W8PNN	VE1KY	W4DLK	W1GCD
W7BJS	W5FCI	W9MSH	VE1CA	W9UHZ	W9BLI
W9SJV	W2AQV	W5FZS	W8PLD	W1SXT	W7CJR

Write for Free Illustrated Booklet Describing the SUPER SKYRIDER and Other Hallicrafters' Receivers

All Hallicrafters Receivers now available on Liberal Time Payments.

the hallicrafters inc.

2603 Indiana Avenue, Chicago, Ill. • Cable Address "Hallicraft" Chicago
America's Leading Manufacturer of Communications Receivers